

THE MOON TILT ILLUSION

ANDREA K. MYERS-BEAGHTON AND ALAN L. MYERS

ABSTRACT. The moon tilt illusion is the startling discrepancy between the direction of the light beam illuminating the moon and the direction of the sun. The illusion arises because the observer erroneously expects a light ray between sun and moon to appear as a line of constant slope according to the positions of the sun and the moon in the sky. This expectation does not correspond to the reality that observation by direct vision or a camera is according to perspective projection, for which the observed slope of a straight line in three-dimensional object space changes according to the direction of observation. Comparing the observed and expected directions of incoming light at the moon, we derive an equation for the magnitude of the moon tilt illusion that can be applied to all configurations of sun and moon in the sky.

1. INTRODUCTION



FIGURE 1. Photograph of the moon tilt illusion. Picture taken one hour after sunset with the moon in the southeast. Camera pointed upwards 45° from the horizon with bottom of camera parallel to the horizon.

The photograph in Figure 1 provides an example of the moon tilt illusion. The moon's illumination is observed to be coming from above, even though the moon is

Date: June 30, 2014.

high in the sky and the sun had set in the west one hour before this photo was taken. The moon is 45° above the horizon in the southeast, 80% illuminated by light from the sun striking the moon at an angle of 17° above the horizontal, as shown by the arrow drawn on the photograph. Our intuition (i.e., the incorrect perception that creates the illusion) is that given the relative positions of the sun and the moon, the light from the sun should be striking the moon from below. The moon tilt illusion is the perceived discrepancy between the angle of illumination of the moon that we observe (and can capture photographically with a camera pointed at the moon) and the angle that we expect from the position of the sun relative to the moon.

The moon tilt illusion is not described in astronomy textbooks because astronomers know that straight lines in object space become great circles on the celestial sphere. Minnaert [5] gives only a passing reference: "...the line connecting the horns of the moon, between its first quarter and full moon, for instance, does not appear to be at all perpendicular to the direction from sun to moon; we apparently think of this direction as being a curved line. Fix this direction by stretching a piece of string taut in front of your eye; however unlikely it may have seemed to you at first you will now perceive that the condition of perpendicularity is satisfied". An article by Schölkopf [8] documents the illusion in an experiment involving 14 subjects by having them indicate their expectation of how the moon's illumination should be oriented with respect to the position of the (visible) sun. He reports that an average discrepancy of 12° is perceived by the subjects between the observable versus expected orientation of the moon's bright limb. Schott's website entitled "'Falsche' Mondneigung" ('False' Moontilt) [9] is devoted to the moon tilt illusion, and features illustrations and useful links. Schott correctly proposes to quantify the effect by comparing the observed tilt angle with the angle from horizontal of the line connecting the moon and sun, but an error in geometry leads to an incorrect expression for the expected tilt. A paper by Glaeser and Schott [2], approaching the phenomenon via the principles of photography, show that the magnitude of the illusion could in theory be measured through comparison of a close-up shot of the moon with a photograph containing both sun and moon, with the camera directed in a specified direction between them (although no equations are given). However, as they point out, in practice it is not feasible since even a wide-angle lens cannot capture both sun and moon in a photo with azimuth differences for which the illusion can be most clearly observed (between 90° and 180°). Berry[1] proposed using a star chart, which is a zenith-center stereoscopic projection of the celestial sphere onto a flat surface, to define the moon tilt illusion as the angle between the projected great circle and a straight moon-sun line drawn on the same chart "mimicking how we might see the sky when lying on our back looking up". Clearly, there exists a lack of consensus in the literature about the explanation of the moon tilt illusion and disagreement about the best way to describe it.

Our aim is to derive an equation for the magnitude of the moon tilt illusion that is straightforward to apply to all configurations of sun and moon in the sky. The viewer's expectation for the direction of incoming light is modeled using vector geometry, which is appropriate for treating 3-D straight lines such as the sun-moon light ray. Analyzing an illusion may seem trivial but the explanation of the moon tilt illusion requires knowledge of the perspective projection basis of human vision, vector algebra,

and geometrical concepts such as orthographic projections, the celestial sphere, and geodesics.

2. SYSTEM OF COORDINATES AND DEFINITIONS

Our analysis of the moon tilt illusion is based upon the location of the sun and moon in the sky. Notation and equations for describing these locations and converting them back and forth between Cartesian and spherical coordinates are covered in this section. The procedure for calculating the moon tilt angle α from the moon's illumination is described.

In astronomy, the locations of stars are given in terms of their right ascension and declination. Since the moon illusion is based on the position of the observer, we use topocentric coordinates (instead of right ascension and declination) for the sun and moon, denoted by azimuth (ϕ) and altitude (η).¹

The altitude η is the angle between the sun (or moon) and the observer's local horizon. The altitude angle (η) is the complement of the polar angle (θ) so azimuth and altitude (ϕ, η) can be written alternatively as spherical coordinates (ϕ, θ). These vary from 0° to 360° for ϕ and from 0° to 180° for θ . Objects with $90^\circ < \theta < 180^\circ$ are below the horizon and therefore invisible. The zenith (directly overhead) is located at $\theta = 0^\circ$.

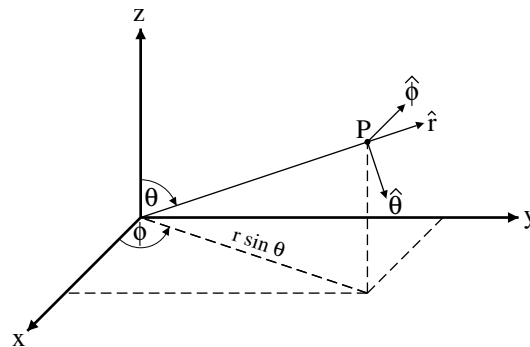

FIGURE 2. Spherical polar coordinates (r, θ, ϕ) of point P . θ is polar angle measured downward from z -axis and ϕ is azimuthal angle measured CCW from the x -axis. The x -axis coincides with due north, the y -axis with due west.

Spherical coordinates for the sun and moon (ϕ, θ) are converted to Cartesian coordinates for vector manipulations such as dot and cross products. The conversion to Cartesian coordinates (x, y, z) can be read from Figure 2:

$$(1) \quad x = r \sin \theta \cos \phi, \quad y = r \sin \theta \sin \phi, \quad z = r \cos \theta$$

¹In physics, the azimuthal angle is defined as positive for counter-clockwise (CCW) rotation from due north (x -direction), with the Cartesian coordinates satisfying the right-hand rule. In navigation, azimuth is defined as positive in the clockwise (CW) direction. We will use the CCW notation for calculations but revert to the more familiar navigational CW direction for the presentation of results in Section 8.

For the reverse transformation from Cartesian to spherical coordinates:

$$(2) \quad r = \sqrt{x^2 + y^2 + z^2}, \quad \theta = \arctan\left(\frac{\sqrt{x^2 + y^2}}{z}\right), \quad \phi = \arctan\left(\frac{y}{x}\right)$$

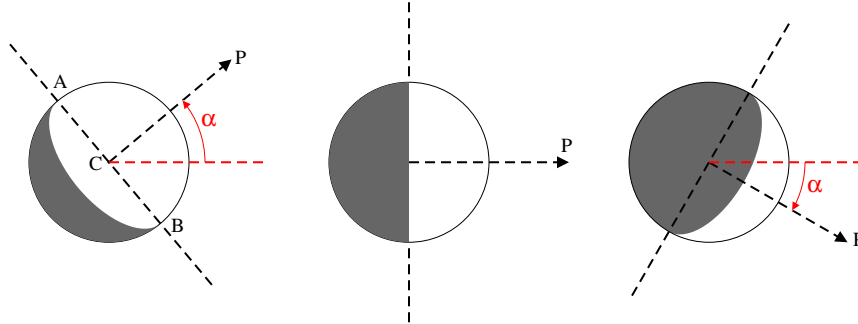

FIGURE 3. Definition of moon pointer with α angle. From left to right, $\alpha = 40^\circ$ (75% illumination), $\alpha = 0^\circ$ (50% illumination), $\alpha = -30^\circ$ (25% illumination).

The moon pointer is defined as the vector CP in Figure 3, where C is the center of the moon and the vector CP has the observed slope of the moon-sun line at point C . The demarcation between illuminated and dark portions of the moon is called the terminator. Line AB connects the two “horns” of the terminator through the moon’s center C . The moon pointer CP is the perpendicular bisector of line AB .

The moon tilt α is the signed angle of the moon’s pointer with the horizontal, positive upward and negative downward. An equation for calculating this angle from the locations of the sun and moon is derived in Section 5. The angle α may be verified experimentally by taking a picture of the moon and using the construction described in Figure 3. The camera is oriented with its lens axis directed at the moon and the bottom of the camera aligned horizontally with the horizon.

3. HOW THE OBSERVED SLOPE OF A STRAIGHT LINE CHANGES

Perspective projection is the basis for human vision. The moon tilt illusion can be understood and explained by the principles of perspective projection of object space onto a two-dimensional viewing surface. Before comparing the observed slope of the moon-sun line with its expected slope, it is necessary to consider how the slope of a straight line depends upon the viewer’s orientation.

While the slope of any straight line in 3-D space with respect to any plane is constant, the *observed* slope of the line changes according to the position of the observer and his line of sight. Similarly, when taking a photograph of the line, its slope recorded on the 2-D photographic image will depend upon the specific direction in which the camera is pointed. Figure 4 records this effect in a set of three photographs of a straight wall-ceiling line. Although the ceiling is, of course, everywhere the same height from the floor, the camera records a 2-D perspective projection of the wall-ceiling line in which straight lines are rendered as straight lines, but the observed

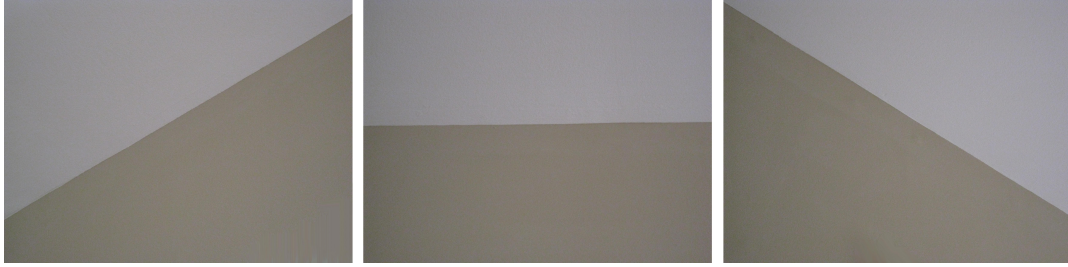

FIGURE 4. Effect of camera angle. Photograph of horizontal line formed by intersection of wall (dark) and ceiling (light). The three photographs were taken consecutively by turning the camera from left to right oriented horizontally. In the photos on the left and right, the slope of the line with respect to the horizontal is 30° .

slope varies depending on the camera direction. Obviously, perspective projection preserves straight lines but not their slopes. This same effect is observed by a human eye scanning the wall-ceiling line, but we have trained our minds to accept and make appropriate adjustments for the oxymoronic concept of a straight line with changing slope.

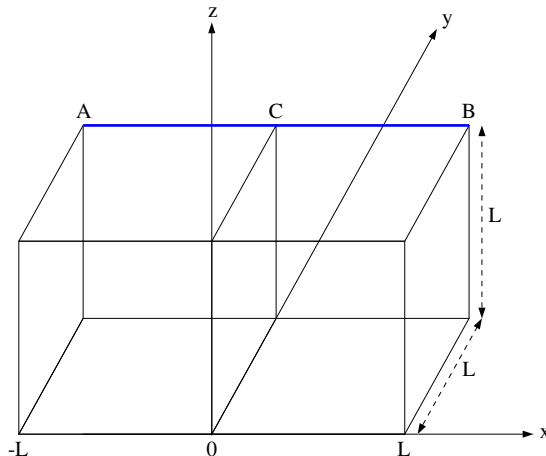

FIGURE 5. Straight line AB in three-dimensional space. Point A is at $(-L, L, L)$, point B is at (L, L, L) , and the midpoint C is at $(0, L, L)$. The observer is located at the origin.

As another example, consider line AB in Figure 5. AB is parallel to the xy plane and thus has a fixed slope of zero with the horizontal. Imagine, as shown by the sketch on Figure 6, that three photographs are taken by pointing the camera at points A , B , and C with the bottom of the camera aligned with the horizontal. The photograph of the line at point A exhibits a positive slope of 30° ; point C a slope of 0° ; and point B a slope of -30° (calculated by Eq. (9)). More photos along the line AB would reveal an observed slope that varies continuously from -30° to 30° . Direct visual observation of this line by an observer at point O would yield the same result: as the eye/head is moved along the horizontal line from left to right, the viewer would

‘see’ a continuously varying slope that depends on the line of sight. This effect is captured by a video [6] which scans a long, straight string of lights at London’s Tower Bridge along the Thames, all at roughly the same distance from the ground. The video shows the observed slope of the string of lights varying continuously along the line: first sloping upwards from the ground on the left, then with zero slope, then sloping downwards to the right. Although the slope changes, stopping the video on any frame records the string of lights as a straight line.

The conclusion is that the slope of a vector which is straight in 3-D object space changes continuously with the viewing angle of the camera (or the human eye) as it is moved along the line. For a particular viewing angle, the slope is constant and the line is straight. For the series of viewing angles necessary to scan the line from beginning to end, the slope varies. Although the above examples treat straight lines that are parallel to the ground, the observed slope of a straight line in 3-D space of any orientation with respect to the horizontal will change with viewing (or camera) perspective.

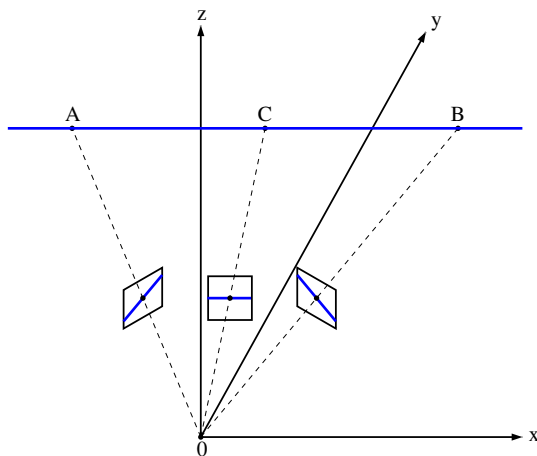

FIGURE 6. Photographing the slope of line AB . The lens axis of a camera located at the origin is pointed consecutively at points $\{A, C, B\}$ along lines OA , OC , OB , respectively, with the bottom of the camera held horizontally. Images of straight line AB are recorded on the 2-D image plane of the camera. Coordinates of points are shown on Figure 5.

4. CAUSE OF MOON TILT ILLUSION

With an understanding of how the *observed* slope of a straight line varies depending upon the direction of the observation, we are in a position to explain the moon tilt illusion. The same principles of perspective that hold for a straight line in 3-D space apply to the straight sun-moon light ray. When we view the slope of the light ray at the moon, which is the only place where we can photograph the direction of the light ray, the slope we observe is exactly what one would expect from the principles of perspective projection that form the basis of human vision or photography. Why, then, does the observer experience a sense that this direction is wrong when turning his head to look at where the light ray originates?

The cause of the moon tilt illusion is simply that the observer is not taking into account that the observed slope of the light ray will change when he turns his head to observe the moon and sun. This perceptual disconnect occurs because the observer cannot see the light ray itself, but only its starting position at the sun and the angle at which it strikes the moon. Lacking any other visual clues (as on earth) to provide more information, he is perceptually unable to ‘fill in the gap’ and envision how the slope of a visible line overhead changes with viewing angle due to perspective projection. Knowing that light travels in straight lines in space but ‘forgetting’ that slope changes as the head turns along a line, the observer expects that when he scans his eyes from sun to moon he would see a straight line of constant slope — even though his head has moved.

Minnaert [5] describes his experience with a searchlight overhead that shows how the mind tricks the viewer: “This tendency of mine to see the course of light as a curve is due to the fact that on one side I see it slope downwards towards the left, and on the other side towards the right. As if the straight lines of an ordinary horizontal telephone wire did not behave in the same way! However, looking at the beams of light at night I have no point of reference in surrounding objects to enable me to estimate distances and nothing is known to me, a priori, of the shape of the beam”.

We calculate the *observed* tilt at the moon and the *expected* slope of the moon-sun line from the known position of the moon and the sun in the sky. The angular difference between observed slope and expected slope quantifies the moon tilt illusion.

5. OBSERVED SLOPE OF MOON-SUN VECTOR

Using the principles of perspective projection which apply to human vision, a general equation is derived for the locus and the slope of a straight line in 3-D object space as a function of the direction of observation. The resulting equation is applied to the specific case of the slope of the moon-sun line where it intersects the moon. Denoting the location of the observer by O, the moon by M, and the sun by S, let \mathbf{m} be the vector OM and \mathbf{s} the vector OS as shown on Figure 7. If the moon-sun vector is called \mathbf{v} , then:

$$(3) \quad \mathbf{v} = \mathbf{s} - \mathbf{m}$$

A parametric equation for the locus of \mathbf{v} is:

$$(4) \quad \mathbf{c} = (1 - \lambda)\mathbf{m} + \lambda\mathbf{s}$$

where \mathbf{c} is a vector to an arbitrary point on \mathbf{v} and $0 \leq \lambda \leq 1$. Let the lens axis of a camera located at the origin be directed at some point on the moon-sun line indicated by the vector \mathbf{c} . The 2-D image plane is then perpendicular to \mathbf{c} . On Figure 7, the intersection of the image plane with \mathbf{c} is placed at the tip of the unit vector $\hat{\mathbf{c}}$. The vector cross product $(\mathbf{s} \times \mathbf{m})$ is perpendicular to the observer-moon-sun plane. The two planes, the image plane and the observer-moon-sun-plane, are defined by their perpendicular vectors \mathbf{c} and $(\mathbf{s} \times \mathbf{m})$, respectively. The cross product of these two vectors (\mathbf{p}) is the line of intersection of the two planes:

$$(5) \quad \mathbf{p} = \mathbf{c} \times (\mathbf{s} \times \mathbf{m})$$

As shown in Figure 7, \mathbf{p} lies in both planes. Similarly, the vector product $(\mathbf{c} \times \mathbf{z})$ is the intersection of the image plane with the horizontal plane shown as the vector \mathbf{h} in Figures 7 and 8.

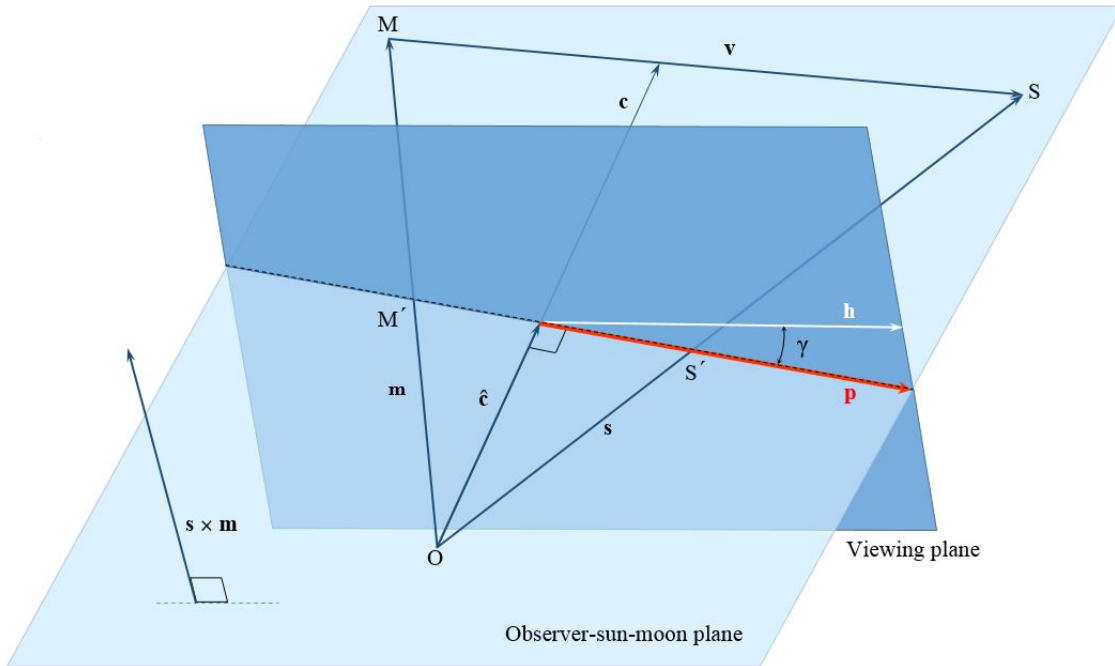

FIGURE 7. Observation of moon-sun line in viewing plane. Planes intersect along line $M'S'$. Observer is located at origin. \mathbf{v} is the moon-sun line and \mathbf{p} is its image on the viewing plane. *Not to scale.* The magnitude of s is almost 400 times the magnitude of \mathbf{m} .

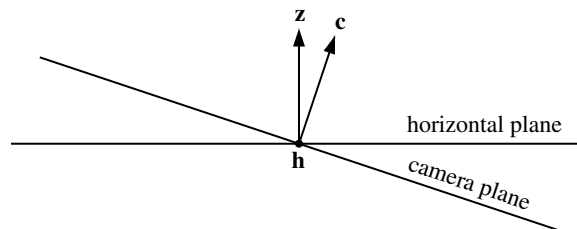

FIGURE 8. View of intersection of horizontal plane and camera plane for both planes perpendicular to the plane of the paper. The horizontal plane is perpendicular to the vertical Cartesian axis \mathbf{z} and the image plane is perpendicular to the vector \mathbf{c} . The vector $\mathbf{h} = \mathbf{c} \times \mathbf{z}$, appearing as a point in the figure, is the line of intersection of the two planes.

The angle γ between the vectors \mathbf{p} and \mathbf{h} in Figure 7 is given by their dot product:

$$(6) \quad \cos \gamma = \frac{\mathbf{p} \cdot \mathbf{h}}{|\mathbf{p}||\mathbf{h}|}$$

or by their cross product:

$$(7) \quad \sin \gamma = \frac{|\mathbf{p} \times \mathbf{h}|}{|p||h|}$$

The normalization step of finding the absolute values of \mathbf{p} and \mathbf{h} is avoided by calculating the tangent of the angle between the vectors \mathbf{p} and \mathbf{h} .

$$(8) \quad \tan \gamma = \frac{\sin \gamma}{\cos \gamma} = \frac{|\mathbf{p} \times \mathbf{h}|}{\mathbf{p} \cdot \mathbf{h}}$$

or written out in full:

$$(9) \quad \tan \gamma = \frac{|[\mathbf{c} \times (\mathbf{s} \times \mathbf{m})] \times [\mathbf{c} \times \mathbf{z}]|}{[\mathbf{c} \times (\mathbf{s} \times \mathbf{m})] \cdot [\mathbf{c} \times \mathbf{z}]}$$

Using Eq. (4) for the camera direction:

$$(10) \quad \tan \gamma = \frac{|[(\lambda \mathbf{s} + (1 - \lambda) \mathbf{m}) \times (\mathbf{s} \times \mathbf{m})] \times [(\lambda \mathbf{s} + (1 - \lambda) \mathbf{m}) \times \mathbf{z}]|}{[(\lambda \mathbf{s} + (1 - \lambda) \mathbf{m}) \times (\mathbf{s} \times \mathbf{m})] \cdot [(\lambda \mathbf{s} + (1 - \lambda) \mathbf{m}) \times \mathbf{z}]}$$

Eq. (10) is for the slope angle (γ) of the moon-sun line projected on the image plane as it is scanned by the eye of the camera ($0 \leq \lambda \leq 1$). It is apparent from Figure (7) that in the observer-moon-sun plane, the direction of \mathbf{p} is unaffected by the lengths or absolute values of \mathbf{m} and \mathbf{s} , for which we henceforth substitute the unit vectors $\hat{\mathbf{m}}$ and $\hat{\mathbf{s}}$, respectively, for computational convenience.

Eq. (10) is the equation for the slope angle (γ) of the moon-sun line \mathbf{v} at any point; the angle which can be verified by photography is the angle α at the moon, as in Figure 1. If the camera is pointed at the moon, $\lambda = 0$ and Eq. (10) becomes:

$$(11) \quad \tan \alpha = \frac{|[\hat{\mathbf{m}} \times (\hat{\mathbf{s}} \times \hat{\mathbf{m}})] \times [\hat{\mathbf{m}} \times \hat{\mathbf{z}}]|}{[\hat{\mathbf{m}} \times (\hat{\mathbf{s}} \times \hat{\mathbf{m}})] \cdot [\hat{\mathbf{m}} \times \hat{\mathbf{z}}]}$$

The value of the angle α is the same for the vectors \mathbf{m} , \mathbf{s} and \mathbf{z} or their corresponding unit vectors, which are used in Eq. (11) to avoid having to know the actual distances of the moon and the sun from the observer. The moon and sun unit vectors are:

$$(12) \quad \hat{\mathbf{m}} = m_x \hat{\mathbf{x}} + m_y \hat{\mathbf{y}} + m_z \hat{\mathbf{z}}$$

$$(13) \quad \hat{\mathbf{s}} = s_x \hat{\mathbf{x}} + s_y \hat{\mathbf{y}} + s_z \hat{\mathbf{z}}$$

and their dot product is:

$$(14) \quad d = \hat{\mathbf{m}} \cdot \hat{\mathbf{s}} = m_x s_x + m_y s_y + m_z s_z$$

As shown in Appendix A, substituting Eqs. (12) and (13) into (11) and using Eq. (14) yields:

$$(15) \quad \boxed{\tan \alpha = \frac{|s_z - dm_z|}{s_x m_y - s_y m_x}}$$

Eq. (31) is explicit for the moon tilt angle α in terms of the components of the \mathbf{m} and \mathbf{s} unit vectors. Using Eq. (1):

$$(16) \quad m_x = \cos \eta_m \cos \phi_m; \quad m_y = \cos \eta_m \sin \phi_m; \quad m_z = \sin \eta_m$$

$$(17) \quad s_x = \cos \eta_s \cos \phi_s; \quad s_y = \cos \eta_s \sin \phi_s; \quad s_z = \sin \eta_s$$

As shown in Appendix B, substitution of Eqs. (16) and (17) into (31), followed by trigonometric manipulation and simplification yields:

$$(18) \quad \tan \alpha = \frac{|\cos \eta_m \tan \eta_s - \sin \eta_m \cos \Delta\phi|}{\sin \Delta\phi}$$

where $\Delta\phi = (\phi_m - \phi_s)$.

The equation for α applies to waxing and waning moons in both hemispheres. The absolute value in the numerator of Eq. (18) affects the sign but not the value of α . The nuisance of insuring that the angle is in the right quadrant can be avoided by discarding the absolute value signs in the numerator and introducing absolute values of $\Delta\phi$ so that:

$$(19) \quad \boxed{\tan \alpha = \frac{\cos \eta_m \tan \eta_s - \sin \eta_m \cos(\Delta\phi)}{\sin(\Delta\phi)}}$$

where it is understood that $\Delta\phi = |\phi_m - \phi_s|$. The sign convention for α is shown on Figure 3, positive for above the horizontal and negative for below the horizontal. The direction of the moon pointer is east or west, depending on the direction of the sun as shown on Figures 10 – 13.

The relationship of Eq. (19) to the “position angle of the moon’s bright limb” [4][9][10] is given in Appendix E.

6. EXPECTED SLOPE OF MOON-SUN VECTOR

The expected slope of the moon-sun vector \mathbf{v} is modeled by the equation:

$$(20) \quad \mathbf{v} = \hat{\mathbf{s}} - \hat{\mathbf{m}}$$

Unit vectors are chosen for \mathbf{m} and \mathbf{s} because we imagine that the sun and moon are equidistant from us. Eq. (20), which should be compared with Eq. (3), is a natural consequence of the 2-D perspective-projection basis of human vision. Objects, especially those of apparent equal size, are judged as equidistant in the absence of additional visual cues such as neighboring objects. Even if observers took into account that the sun is much farther away from the earth than the moon, they would still experience an illusion generated by the perspective basis of vision. For a setting sun, they would expect the moon (in any position) to be illuminated from the horizontal, leading to an illusion equal to the observed α tilt.

At the moon, the observed angle α is already known and we seek to compare it with the angle β between the horizontal and the expected light ray from the sun. If the moon and sun are at the same altitude, $\beta = 0$ because the expected moon-sun line is horizontal, parallel to the horizon. If the moon is located directly above the sun (a view reserved for tropical zones), $\beta = -90$ degrees because the expected moon-sun line is vertical. Both angles for β were obtained by orthogonal projections of \mathbf{v} onto a vertical plane perpendicular to the azimuth of the moon. For angles between 0 and 90 degrees, the expected angle β is found the same way, by an orthogonal projection of the moon-sun vector \mathbf{v} .

The orthographic projection of \mathbf{v} onto a vertical plane perpendicular to the azimuth of the moon is shown on Figure 9. The vector \mathbf{n} normal to this plane is:

$$(21) \quad \mathbf{n} = m_x \hat{\mathbf{x}} + m_y \hat{\mathbf{y}}$$

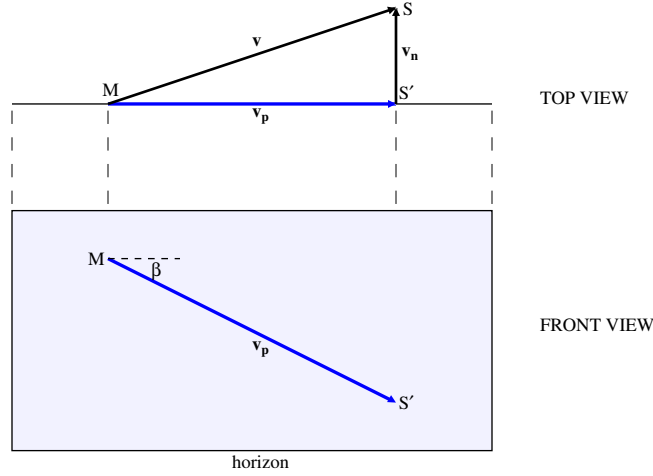

FIGURE 9. Orthogonal projection \mathbf{v}_p of moon-sun vector \mathbf{v} onto vertical plane with normal vector \mathbf{n} .

where m_x and m_y are the x and y components of the $\hat{\mathbf{m}}$ vector. The absolute value of the \mathbf{n} vector is:

$$(22) \quad |\mathbf{n}| = \sqrt{m_x^2 + m_y^2}$$

and the unit normal vector is:

$$(23) \quad \hat{\mathbf{n}} = \frac{\mathbf{n}}{|\mathbf{n}|} = \frac{\mathbf{n}}{\sqrt{m_x^2 + m_y^2}}$$

The vector \mathbf{v}_n in Figure 9 is given by:

$$(24) \quad \mathbf{v}_n = (\mathbf{v} \cdot \hat{\mathbf{n}})\hat{\mathbf{n}}$$

so the projection \mathbf{v}_p on the vertical plane is:

$$(25) \quad \mathbf{v}_p = \mathbf{v} - \mathbf{v}_n = \mathbf{v} - (\mathbf{v} \cdot \hat{\mathbf{n}})\hat{\mathbf{n}}$$

The horizontal unit vector lying in the vertical plane is $\hat{\mathbf{h}} = \hat{\mathbf{n}} \times \hat{\mathbf{z}}$. The desired angle between \mathbf{v}_p and $\hat{\mathbf{h}}$ is given by the ratio of their cross and dot products as in Eq. (8):

$$(26) \quad \tan \beta = \frac{|\mathbf{v}_p \times (\hat{\mathbf{n}} \times \hat{\mathbf{z}})|}{\mathbf{v}_p \cdot (\hat{\mathbf{n}} \times \hat{\mathbf{z}})}$$

As shown in Appendix C, substitution of Eqs. (12) and (13) into (26) and using Eqs. (23) – (25) gives:

$$(27) \quad \tan \beta = \frac{|s_z - m_z| \sqrt{m_x^2 + m_y^2}}{s_x m_y - s_y m_x}$$

As shown in Appendix D, conversion of the Cartesian components of the moon and sun vectors to angles yields:

$$(28) \quad \tan \beta = -\frac{|\sin \eta_m - \sin \eta_s|}{\cos \eta_s \sin(\Delta\phi)}$$

where $\Delta\phi = (\phi_m - \phi_s)$. This equation for β applies to waxing and waning moons in both hemispheres. The nuisance of insuring that the angle is in the right quadrant is avoided by writing Eq. (28) in the form:

$$(29) \quad \boxed{\tan \beta = -\frac{(\sin \eta_m - \sin \eta_s)}{\cos \eta_s \sin(\Delta\phi)}}$$

where it is understood that $\Delta\phi = |\phi_m - \phi_s|$. The sign convention for the β pointer is the same as for the α pointer: a positive value for β corresponds to a direction upward from the horizontal and a negative value corresponds to a direction downward from the horizontal, pointing east or west depending on the location of the sun. Usually the altitude of the moon is higher than that of the sun and β is negative.

7. MAGNITUDE OF MOON TILT ILLUSION

The moon tilt illusion is defined as the difference (δ) between the slope angle of the observed moon-sun line (α) and slope angle of the expected moon-sun line (β):

$$(30) \quad \boxed{\delta = \alpha - \beta}$$

For example, consider the configuration for Figure 1. The locations of the sun and moon are the altitudes $\eta_m = 45^\circ$, $\eta_s = -15^\circ$, and an azimuth difference $\Delta\phi = 128^\circ$. The illumination of the moon in the photograph is 80%, which agrees with the calculated value [10]. From Eq. (19), $\alpha = 17^\circ$, as confirmed by the photograph. Eq. (29) gives $\beta = -52^\circ$ and from Eq. (30), $\delta = 17 - (-52) = 69^\circ$, consistent with the viewer's expectation that the incoming light should be strongly angled from below the horizontal.

8. CHARTS OF MOON TILT ILLUSION AT SUNRISE AND SUNSET

Conditions for viewing the moon tilt illusion are most favorable when the sun and moon are visible in the sky at the same time. Figures 10 – 13 are charts for the sun at sunrise and sunset in the northern and southern hemispheres. Whether or not a particular configuration is visible depends upon the latitude of the observer. For example, in Figure 10 for a waxing moon, the horizontal “boat” moon at high altitude in the west is observed near the equator but not in temperate zones.

The fraction of the moon illuminated is a geometric function of the locations of the sun and moon [10].

The magnitude of the moon tilt illusion is defined by δ , the angular difference between the observed (red) arrow and the expected (blue) arrow. The limits of δ are 0° for a new moon and 180° for a full moon. For the crescent phase, the δ angle is almost too small to be apparent with the naked eye. For the gibbous phase, the δ angle is large but difficult to discern as the illumination approaches 90 percent, in which case the direction of the (red) moon pointer becomes uncertain. The most impressive illusion occurs at sunset when the gibbous moon is at high altitude in the southwest or at sunrise when the gibbous moon is at high altitude in the southeast (both cases for the northern hemisphere).

The charts are for the sun setting due west or rising due east, which occurs at all latitudes during the spring and fall equinoxes. The *difference* in azimuths of sun and moon, not the specific azimuth of the sun, determines the magnitude of the illusion;

therefore corrections can be made for the sun rising or setting at azimuths other than due east or west by translating the entire set of images horizontally to the right or left.

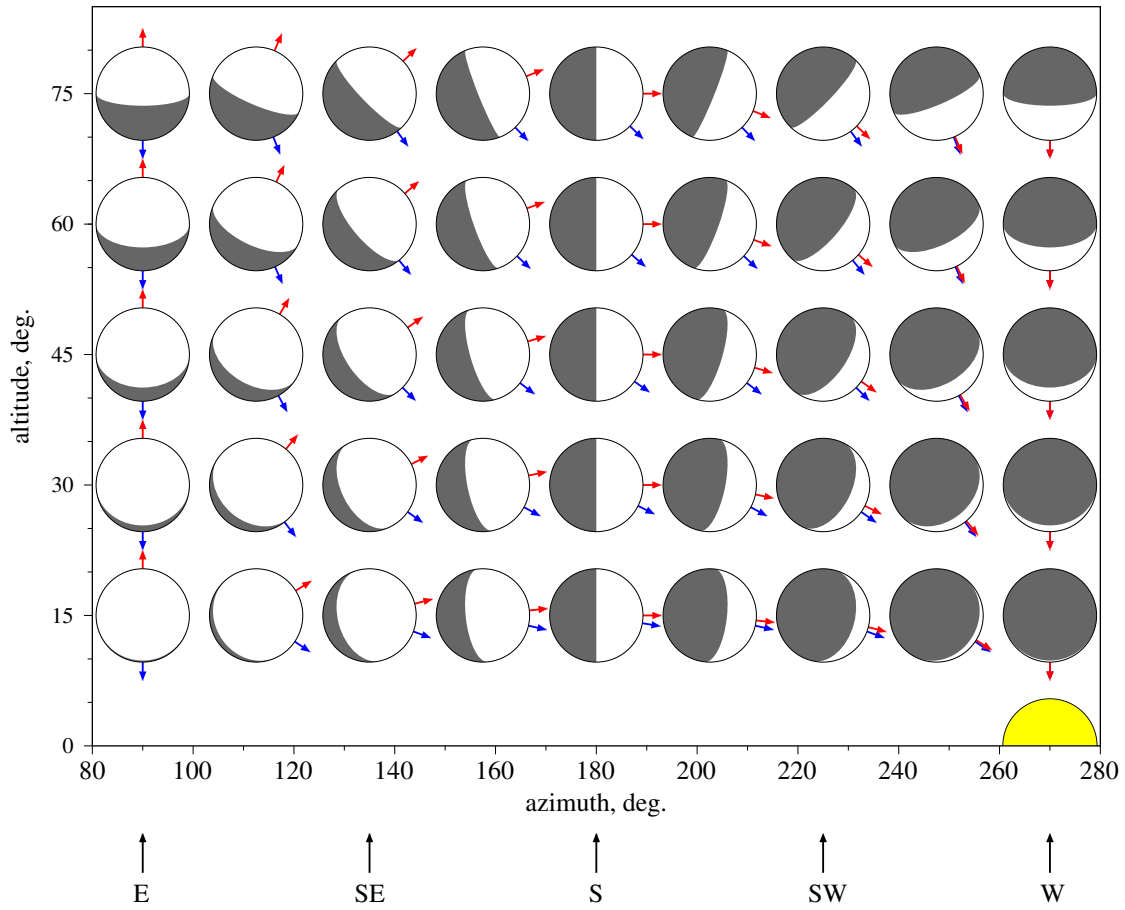

FIGURE 10. Moon tilt illusion for waxing phases in northern hemisphere. Sun is setting due west. Red line is observed slope and blue line is expected slope of moon-sun line. Azimuth measured CW from north.

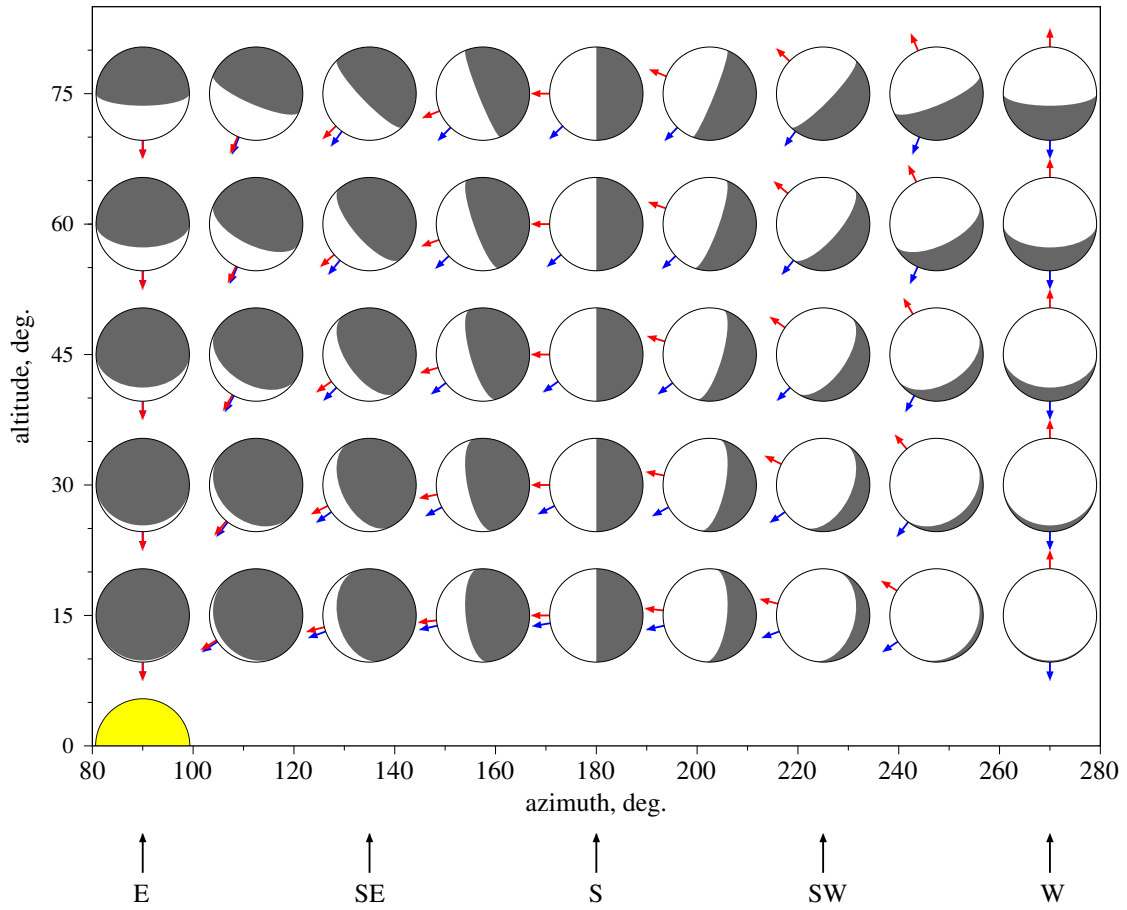

FIGURE 11. Moon tilt illusion for waning phases in northern hemisphere. Sun is rising due east. Red line is observed slope and blue line is expected slope of moon-sun line. Azimuth measured CW from north.

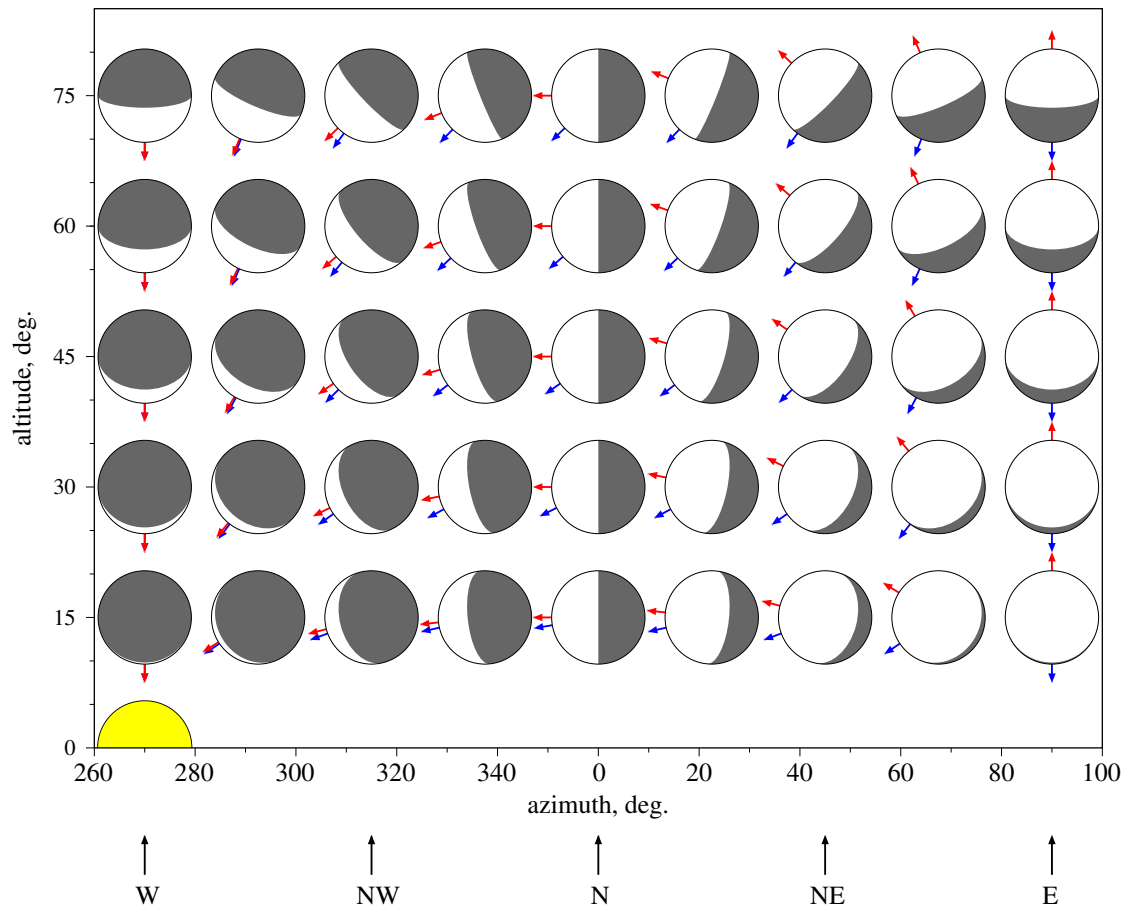

FIGURE 12. Moon tilt illusion for waxing phases in southern hemisphere. Sun is setting due west. Red line is observed slope and blue line is expected slope of moon-sun line. Azimuth measured CW from north.

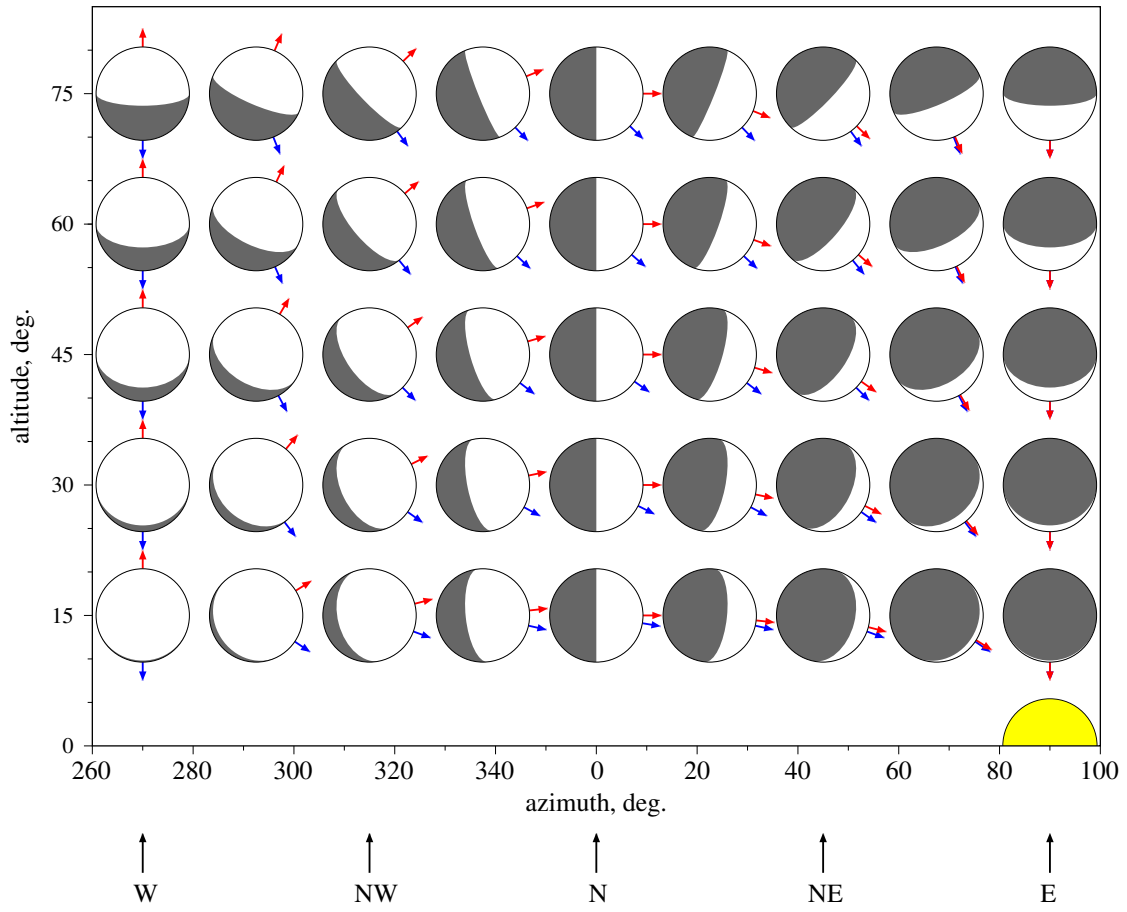

FIGURE 13. Moon tilt illusion for waning phases in southern hemisphere. Sun is rising due east. Red line is observed slope and blue line is expected slope of moon-sun line. Azimuth measured CW from north.

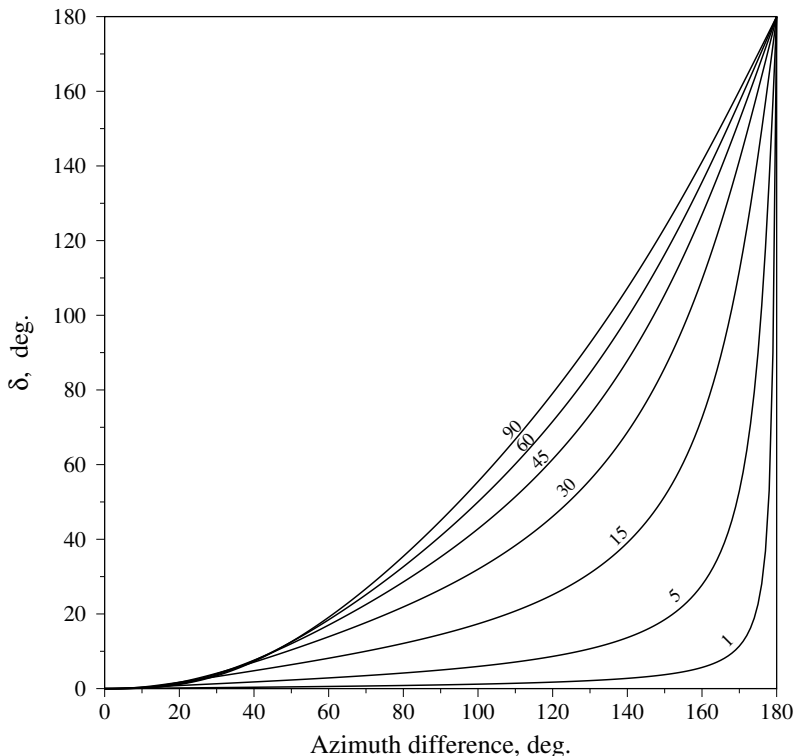

FIGURE 14. Magnitude of moon tilt illusion (δ) for rising or setting sun as function of azimuth difference ($\Delta\phi$) between sun and moon. Parameters of curves are altitude of moon (η_m) in degrees.

Figure 14 summarizes the dependence of the moon tilt illusion upon the altitude of the moon and the azimuth difference between sun and moon, for the case of rising or setting sun. For a crescent moon with an azimuth difference less than 20 degrees, the illusion is imperceptible to the naked eye.

The maximum altitude at which an illusion can be observed when the sun is rising or setting depends upon its illumination as shown in Figure 15. For example, a crescent moon 10 percent illuminated is observed only at altitudes below 36.9 degrees; a gibbous moon 80 percent illuminated is observed only at altitudes below 53.1 degrees.

Up to this point attention has been focused upon the moon tilt illusion at the moment of sunrise and sunset for obvious reasons: the moon is usually invisible during the day and during the night the sun is invisible. Only when the moon and the sun are visible in the sky at the same time is it possible to imagine a straight line connecting them, which also occurs just after sunrise and just before sunset. The illusion is striking when the moon and sun have the same altitude so that the expected illumination is horizontal. Figure 16 shows a gibbous moon for the case when moon and sun have the same altitude of 15 degrees. In this configuration, the difference in azimuths is 135.6 degrees, corresponding to the sun about an hour before sunset and the moon 80 percent illuminated. The blue arrow is the expected direction of the sun and the red line is the actual moon pointer which is 32.4 degrees above horizontal. Since $\beta = 0$, the magnitude of the moon tilt illusion is $\delta = \alpha = 32.4$ degrees.

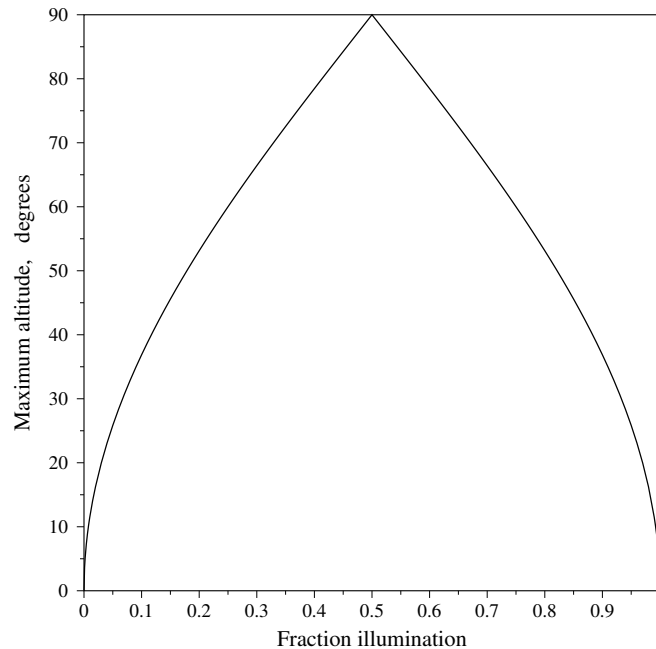

FIGURE 15. Maximum altitude of moon as a function of its illumination for rising and setting sun.

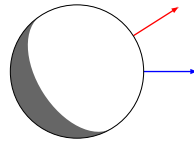

FIGURE 16. Moon pointer (red) for case when moon and sun both have altitudes of 15 degrees. Illumination is 80 percent and the azimuth difference of moon and sun is 135.6 degrees. Blue line is expected direction of sun.

9. MAPPING ON THE CELESTIAL SPHERE: THE GREAT-CIRCLE GEODESIC

Astronomers rely upon the celestial sphere model for maps of the sky because locations of stars and constellations depend only on their right ascension and declination. For the topocentric model used for the sun and the moon, location is specified by azimuth and altitude. All objects in the sky are assumed to be located at the same distance from the observer, as if pasted upon the surface of an imaginary sphere surrounding the observer. Astronomers, for whom the celestial sphere model is a basic tool for mapping the stars, are not surprised by the apparently curved path of light from the sun to the moon because they know that straight lines in 3-D object space are transformed to great-circle arcs on the imaginary celestial sphere. Straight lines in space are not *actually* transformed into great circle arcs on a visible celestial sphere. Great circle arcs cannot be captured on photographs and visible straight lines are not

perceived as arcs when scanned by human vision. However, the loci of these arcs can be plotted on maps.

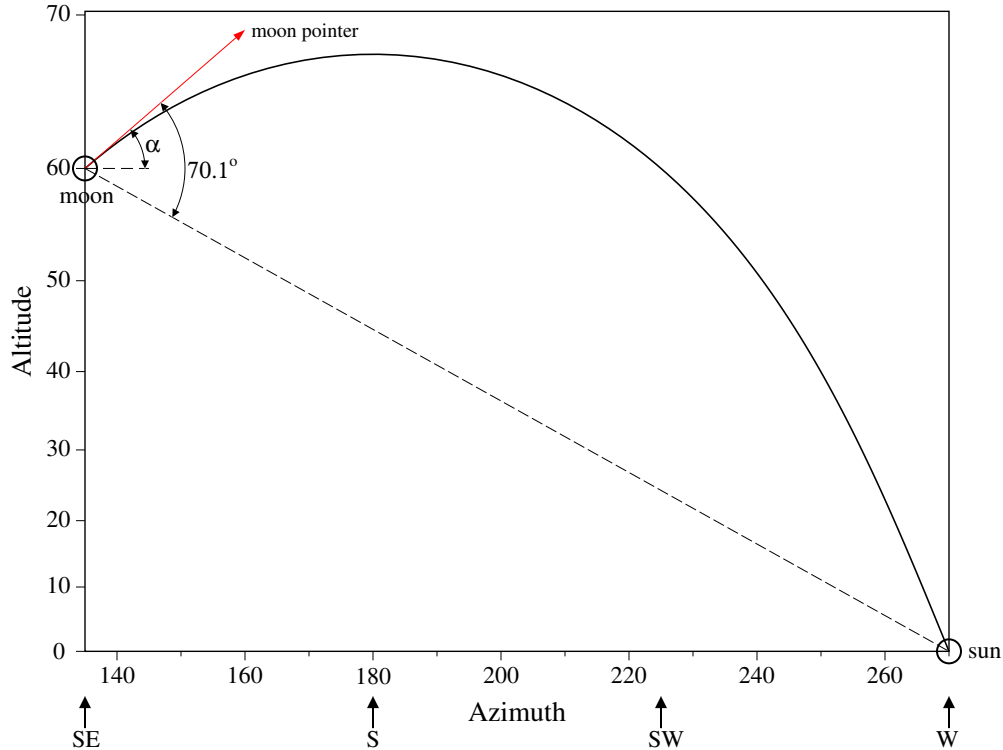

FIGURE 17. Map of moon-sun line. Azimuth of moon is southeast and azimuth of sun is west. Altitude of moon is 60° and altitude of sun is 0° . Moon tilt angle $\alpha = 40.9^\circ$. Azimuth measured CW from north.

Consider specifically the great-circle arc for the configuration of moon and sun shown on Figure 17. The solid line is the moon-sun vector \mathbf{v} obtained from parametric Eqn. (4) and plotted on a Mercator map after conversion to spherical coordinates. This locus is a geodesic for the shortest distance between the moon and the sun on the surface of the imaginary celestial sphere. The great-circle nomenclature is familiar to pilots navigating the shortest distance between two points on the surface of the earth. The Mercator projection of the locus has the advantage of being conformal in the sense that an angle (e.g., α) between two intersecting lines in 3-D object space is preserved on the map.

The temptation to draw the straight (dashed) line between the moon and the sun on Figure 17 and define the angle between the straight line and the moon pointer (70.1 degrees) as the magnitude of the moon tilt illusion is irresistible. This would be misleading and erroneous unless the objective is to define the illusion on a map instead of looking at the sky. Any straight line drawn on the map would be a loxodrome on the surface of the celestial sphere. Moreover, the Mercator projection becomes more distorted with increasing altitude and is not even defined for the zenith.

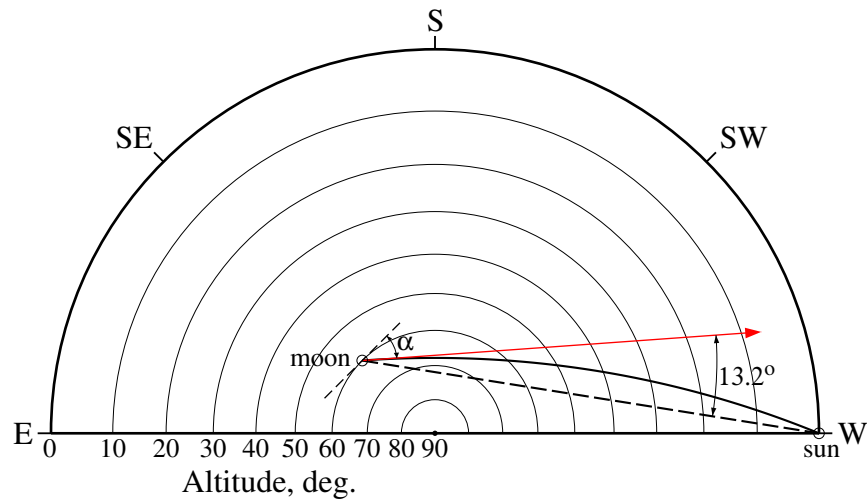

FIGURE 18. Star chart of moon-sun line. Azimuth of moon is southeast and azimuth of sun is west. Altitude of moon is 60° and altitude of sun is 0° . Moon tilt angle $\alpha = 40.9^\circ$.

The same great circle arc is drawn on the star chart of Figure 18. The star chart, like the Mercator map, is conformal for angles formed by intersecting lines. The great circle arc between the sun and the moon is identical on both maps, passing through an altitude of 60° at the SW azimuth. The angle α of the moon pointer with the horizontal is 40.9° on both maps. However, the straight (dashed) lines on these two maps are different. On the Mercator map, the dashed line at the azimuth pointing south has an altitude of 44° but on the star chart its altitude at the same azimuth is 72° . Not only are these dashed lines different but they are not even straight lines in 3-D object space. The difference between the moon pointer and the dashed line is 70.1° on the Mercator map and -13.2° on the star chart. The signs are different because the dashed line on the Mercator map points downward from the horizontal and the dashed line on the star chart points upward from the horizontal, even higher than the moon pointer. Neither map is useful for explaining the moon tilt illusion because the expected straight line drawn on these maps does not exist in 3-D object space.

10. PHOTOGRAPHING THE MOON TILT ILLUSION

Photography of the moon tilt illusion has been dismissed as a “deceitful venture” [2]. Deceitful or not, it is highly problematic. An idealized pinhole camera is based on the principles of perspective projection of 3-D object space onto a 2-D image plane. A photograph taken by pointing a pinhole camera at the midpoint of the moon-sun vector distorts the circular moon into an ellipse with its moon pointer directed exactly at the sun [2]. Thus, in a photograph taken by a properly aimed pinhole camera, the moon tilt illusion vanishes.

Modern cameras use lenses whose properties are designed to deliver a rectilinear or curvilinear image. Rectilinear lenses reduce barrel or pincushion distortion from

the image but such lenses are difficult to manufacture for the wide angles (90° and above) needed to record both the sun and the moon on a single photograph. A photograph [3] of the moon and sun at an azimuth difference of 80° containing a leaning tower and unnaturally leaning trees illustrates the difficulty of eliminating distortion in a wide-angle photograph.

Acknowledgment

The authors are grateful to Emeritus Professor Benjamin Shen and Lecturer Mitchell Struble at the University of Pennsylvania, Professor Michael Berry at Bristol University, and Professor Zeev Vager at the Weizmann Institute of Science for valuable discussion and advice.

Notation

\mathbf{c}	camera vector, perpendicular to camera plane
\mathbf{m}	moon vector OM
\mathbf{n}	normal vector to vertical plane
\mathbf{p}	projection of vector \mathbf{v} on camera plane
\mathbf{r}	radius vector
\mathbf{s}	sun vector OS
$\mathbf{x}, \mathbf{y}, \mathbf{z}$	Cartesian coordinate vectors
\mathbf{v}	moon-sun vector MS
$\mathbf{v}_\mathbf{n}$	projection of \mathbf{v} on \mathbf{n}
$\mathbf{v}_\mathbf{p}$	projection of \mathbf{v} on vertical plane
α	observed angle of moon pointer with horizontal
β	expected angle of moon pointer with horizontal
δ	difference of observed and expected angles of moon pointer with horizontal
η	altitude of moon or sun
θ	angle of moon or sun measured from zenith
λ	parameter for specifying points on moon-sun vector
ϕ	azimuth of moon or sun
χ	position angle of moon's bright limb
$\hat{}$	"hat" symbol for unit vector

REFERENCES

- [1] M.V. Berry, *Nature's optics and our understanding of light*, Contemp.Phys., in press (2015).
- [2] Georg Glaeser and Karlheinz Schott, *Geometric Considerations about Seemingly Wrong Tilt of Crescent Moon*, KoG **13**, 19–26 (2009),
http://hrcak.srce.hr/index.php?show=clanak&id_clanak_jezik=73428
- [3] Jerry Lodriguss, *A Different Moon Illusion*.
http://www.astropix.com/HTML/L_STORY/MOONILL.HTM
- [4] Jean Meeus, *Astronomical Algorithms*, 2nd Edition, William-Bell, Inc., Richmond, Virginia, USA (1998), p. 346.
- [5] M. Minnaert, *The Nature of Light and Colour in the Open Air*, Dover Publications Inc. (1954).
- [6] Andrea Myers-Beaghton, *Tower Bridge Video*,
<https://www.youtube.com/watch?v=Pt9iY-2XtDI>
- [7] Alan L. Myers, *The Moon Tilt Illusion*,
<http://www.upenn.edu/emeritus/essays/MyersMoon.html>
- [8] Bernhard Schölkopf, *The Moon Tilt Illusion Perception* **27**, 1229–1232 (1998).
<http://www.perceptionweb.com/abstract.cgi?id=p271229>
- [9] Karlheinz Schott, *"Falsche" Mondneigung - Wohin zeigt die Mondsichel?*,
<http://falsche-mondneigung.jimdo.com/>

- [10] D.B. Taylor, S.A. Bell, and J.L. Hilton, *Computation of the Quantities Describing the Lunar Librations in The Astronomical Almanac*, Appendix C.
<http://astro.ukho.gov.uk/data/tn/naotn74.pdf>

APPENDIX A. α FROM VECTOR COMPONENTS

Reduce Eq. (11):

$$\tan \alpha = \frac{|[\hat{\mathbf{m}} \times (\hat{\mathbf{s}} \times \hat{\mathbf{m}})] \times [\hat{\mathbf{m}} \times \hat{\mathbf{z}}]|}{|[\hat{\mathbf{m}} \times (\hat{\mathbf{s}} \times \hat{\mathbf{m}})] \cdot [\hat{\mathbf{m}} \times \hat{\mathbf{z}}]|}$$

to component form.

Expansion of the vector triple product \mathbf{p} gives:

$$\mathbf{p} = \hat{\mathbf{m}} \times (\hat{\mathbf{s}} \times \hat{\mathbf{m}}) = (\hat{\mathbf{m}} \cdot \hat{\mathbf{m}})\hat{\mathbf{s}} - (\hat{\mathbf{m}} \cdot \hat{\mathbf{s}})\hat{\mathbf{m}} = \hat{\mathbf{s}} - d\hat{\mathbf{m}}$$

where d is the dot product $(\hat{\mathbf{m}} \cdot \hat{\mathbf{s}})$. The expanded numerator of Eq. (11) is:

$$|\mathbf{p} \times (\hat{\mathbf{m}} \times \hat{\mathbf{z}})| = |(\mathbf{p} \cdot \hat{\mathbf{z}})\hat{\mathbf{m}} - (\mathbf{p} \cdot \hat{\mathbf{m}})\hat{\mathbf{z}}|$$

But

$$\mathbf{p} \cdot \hat{\mathbf{m}} = (\hat{\mathbf{s}} - d\hat{\mathbf{m}}) \cdot \hat{\mathbf{m}} = d - d = 0$$

so

$$|\mathbf{p} \times (\hat{\mathbf{m}} \times \hat{\mathbf{z}})| = |\mathbf{p} \cdot \hat{\mathbf{z}}| = |(\hat{\mathbf{s}} - d\hat{\mathbf{m}}) \cdot \hat{\mathbf{z}}| = |s_z - dm_z|$$

The denominator of Eq. (11) is:

$$\mathbf{p} \cdot (\hat{\mathbf{m}} \times \hat{\mathbf{z}}) = (\hat{\mathbf{s}} - d\hat{\mathbf{m}}) \cdot (\hat{\mathbf{m}} \times \hat{\mathbf{z}}) = \hat{\mathbf{s}} \cdot (\hat{\mathbf{m}} \times \hat{\mathbf{z}})$$

because $(\hat{\mathbf{m}} \cdot \hat{\mathbf{m}} \times \hat{\mathbf{z}}) = (\hat{\mathbf{m}} \times \hat{\mathbf{m}} \cdot \hat{\mathbf{z}}) = 0$. From $(\hat{\mathbf{m}} \times \hat{\mathbf{z}}) = (m_y, -m_x, 0)$ and $\mathbf{s} = (s_x, s_y, s_z)$:

$$\mathbf{p} \cdot (\hat{\mathbf{m}} \times \hat{\mathbf{z}}) = s_x m_y - s_y m_x$$

Therefore Eq. (11) in component form is:

$$\tan \alpha = \frac{|s_z - dm_z|}{s_x m_y - s_y m_x}$$

APPENDIX B. α FROM ALTITUDE AND AZIMUTH ANGLES

Convert Eq. (31):

$$(31) \quad \tan \alpha = \frac{|s_z - dm_z|}{s_x m_y - s_y m_x}$$

to altitude and azimuth angles of sun and moon.

The azimuth and altitude angles are given by Eqs. (16) and (17). The dot product is:

$$\begin{aligned} d = \hat{\mathbf{m}} \cdot \hat{\mathbf{s}} &= \cos \eta_m \cos \eta_s \cos \phi_m \cos \phi_s + \cos \eta_m \cos \eta_s \sin \phi_m \sin \phi_s + \sin \eta_m \sin \eta_s \\ &= (\sin \phi_m \sin \phi_s + \cos \phi_s \cos \phi_m)(\cos \eta_s \cos \eta_m) + \sin \eta_m \sin \eta_s \\ &= \cos(\Delta\phi) \cos \eta_s \cos \eta_m + \sin \eta_m \sin \eta_s \end{aligned}$$

where $\Delta\phi = (\phi_m - \phi_s)$.

$$\begin{aligned} s_z - dm_z &= \sin \eta_s - \sin \eta_m [\cos(\Delta\phi) \cos \eta_s \cos \eta_m + \sin \eta_m \sin \eta_s] \\ &= \sin \eta_s (1 - \sin^2 \eta_m) - \sin \eta_m \cos \eta_m \cos \eta_s \cos(\Delta\phi) \\ &= \sin \eta_s \cos^2 \eta_m - \sin \eta_m \cos \eta_m \cos \eta_s \cos(\Delta\phi) \end{aligned}$$

$$\begin{aligned}
s_x m_y - s_y m_x &= \cos \eta_s \cos \phi_s \cos \eta_m \sin \phi_m - \cos \eta_s \sin \phi_s \cos \eta_m \cos \phi_m \\
&= \cos \eta_s \cos \eta_m (\sin \phi_m \cos \phi_s - \cos \phi_m \sin \phi_s) \\
&= \cos \eta_s \cos \eta_m \sin(\Delta\phi)
\end{aligned}$$

From Eq. (31):

$$\tan \alpha = \frac{|\sin \eta_s \cos^2 \eta_m - \sin \eta_m \cos \eta_m \cos \eta_s \cos(\Delta\phi)|}{\cos \eta_s \cos \eta_m \sin(\Delta\phi)}$$

Division yields:

$$\tan \alpha = \frac{|\cos \eta_m \tan \eta_s - \sin \eta_m \cos(\Delta\phi)|}{\sin(\Delta\phi)}$$

APPENDIX C. β FROM VECTOR COMPONENTS

Reduce the vector equation:

$$\tan \beta = \frac{|\mathbf{v}_p \times (\hat{\mathbf{n}} \times \hat{\mathbf{z}})|}{\mathbf{v}_p \cdot (\hat{\mathbf{n}} \times \hat{\mathbf{z}})}$$

to component form.

$$\begin{aligned}
\mathbf{v}_p &= \mathbf{v} - (\mathbf{v} \cdot \hat{\mathbf{n}})\hat{\mathbf{n}} \\
\mathbf{v}_p \times (\hat{\mathbf{n}} \times \hat{\mathbf{z}}) &= (\mathbf{v}_p \cdot \hat{\mathbf{z}})\hat{\mathbf{n}} - (\mathbf{v}_p \cdot \hat{\mathbf{n}})\hat{\mathbf{z}}
\end{aligned}$$

But \mathbf{v}_p is perpendicular to $\hat{\mathbf{n}}$ so:

$$\begin{aligned}
\mathbf{v}_p \times (\hat{\mathbf{n}} \times \hat{\mathbf{z}}) &= (\mathbf{v}_p \cdot \hat{\mathbf{z}})\hat{\mathbf{n}} \\
&= (\mathbf{v} \cdot \hat{\mathbf{z}})\hat{\mathbf{n}} - (\mathbf{v} \cdot \hat{\mathbf{n}})(\hat{\mathbf{n}} \cdot \hat{\mathbf{z}})\hat{\mathbf{n}} \\
&= (\mathbf{v} \cdot \hat{\mathbf{z}})\hat{\mathbf{n}}
\end{aligned}$$

because $\hat{\mathbf{n}}$ is perpendicular to $\hat{\mathbf{z}}$.

$$\begin{aligned}
\mathbf{v} &= \hat{\mathbf{s}} - \hat{\mathbf{m}} = (s_x - m_x)\hat{\mathbf{x}} + (s_y - m_y)\hat{\mathbf{y}} + (s_z - m_z)\hat{\mathbf{z}} \\
|\mathbf{v}_p \times (\hat{\mathbf{n}} \times \hat{\mathbf{z}})| &= |\mathbf{v} \cdot \hat{\mathbf{z}}| = |v_z| = |s_z - m_z|
\end{aligned}$$

The denominator is the scalar triple product:

$$\begin{aligned}
\mathbf{v}_p \cdot (\hat{\mathbf{n}} \times \hat{\mathbf{z}}) &= \mathbf{v} \cdot (\hat{\mathbf{n}} \times \hat{\mathbf{z}}) - (\hat{\mathbf{v}} \cdot \hat{\mathbf{n}})[\hat{\mathbf{n}} \cdot (\hat{\mathbf{n}} \times \hat{\mathbf{z}})] \\
&= \mathbf{v} \cdot (\hat{\mathbf{n}} \times \hat{\mathbf{z}})
\end{aligned}$$

because $\hat{\mathbf{n}} \cdot (\hat{\mathbf{n}} \times \hat{\mathbf{z}}) = (\hat{\mathbf{n}} \times \hat{\mathbf{n}}) \cdot \hat{\mathbf{z}} = 0$.

$$\begin{aligned}
\mathbf{n} \times \hat{\mathbf{z}} &= (m_x, m_y, 0) \times (0, 0, 1) = (m_y, -m_x, 0) \\
\mathbf{v} \cdot (\mathbf{n} \times \hat{\mathbf{z}}) &= [(s_x - m_x), (s_y - m_y), (s_z - m_z)] \cdot (m_y, -m_x, 0) \\
&= s_x m_y - s_y m_x
\end{aligned}$$

In terms of the normalized vector $\hat{\mathbf{n}}$:

$$\mathbf{v} \cdot (\hat{\mathbf{n}} \times \hat{\mathbf{z}}) = \frac{s_x m_y - s_y m_x}{\sqrt{m_x^2 + m_y^2}}$$

Substituting results for the numerator and denominator of $\tan \beta$:

$$\tan \beta = \frac{|s_z - m_z| \sqrt{m_x^2 + m_y^2}}{s_x m_y - s_y m_x}$$

APPENDIX D. β FROM ALTITUDE AND AZIMUTH ANGLES

Convert:

$$\tan \beta = \frac{|s_z - m_z| \sqrt{m_x^2 + m_y^2}}{s_x m_y - s_y m_x}$$

to altitude and azimuth angles of sun and moon. Azimuth and altitude angles are given by Eqs. (16) and (17).

$$m_x^2 + m_y^2 = \cos^2 \eta_m \cos^2 \phi_m + \cos^2 \eta_m \sin^2 \phi_m = \cos^2 \eta_m$$

$$\sqrt{m_x^2 + m_y^2} = \cos \eta_m$$

$$(s_z - m_z) = \sin \eta_s - \sin \eta_m$$

See Appendix B for the derivation of:

$$s_x m_y - s_y m_x = \cos \eta_s \cos \eta_m \sin(\Delta\phi)$$

where $\Delta\phi = (\phi_m - \phi_s)$.

$$\begin{aligned} \tan \beta &= -\frac{|m_z - s_z| \sqrt{m_x^2 + m_y^2}}{s_x m_y - s_y m_x} = -\frac{\cos \eta_m |\sin \eta_m - \sin \eta_s|}{\cos \eta_s \cos \eta_m \sin(\Delta\phi)} \\ &= -\frac{|\sin \eta_m - \sin \eta_s|}{\cos \eta_s \sin(\Delta\phi)} \end{aligned}$$

APPENDIX E. POSITION ANGLE OF MIDPOINT OF MOON'S BRIGHT LIMB

The angle of the moon's tilt from the horizontal is given by Eq. (19):

$$\tan \alpha = \frac{\cos \eta_m \tan \eta_s - \sin \eta_m \cos \Delta\phi}{\sin \Delta\phi}$$

where $\Delta\phi = (\phi_m - \phi_s)$. Let χ be the complement of α :

$$\chi = 90 - \alpha$$

so that χ is the angle of the moon pointer with the vertical unit vector $\hat{\mathbf{z}}$. It follows that:

$$\tan \chi = \frac{\sin \Delta\phi}{\cos \eta_m \tan \eta_s - \sin \eta_m \cos \Delta\phi}$$

which may be written:

$$\tan \chi = \frac{\cos \eta_s \sin \Delta\phi}{\cos \eta_m \sin \eta_s - \cos \eta_s \sin \eta_m \cos \Delta\phi}$$

χ in this equation is called the position angle of the midpoint of the moon's bright limb [4][10], measured from the north point of the disk, with $0 \leq \chi \leq 360^\circ$. Altitudes (η) and azimuths (ϕ) are replaced by declinations and right ascensions, respectively.

ANDREA K. MYERS-BEAGHTON

DEPARTMENT OF LIFE SCIENCES, IMPERIAL COLLEGE LONDON, U.K.

URL: <http://www.imperial.ac.uk/people/a.beaghton>

E-mail address: a.beaghton@imperial.ac.uk

ALAN L. MYERS

CHEMICAL AND BIOMOLECULAR ENGINEERING, UNIVERSITY OF PENNSYLVANIA,
PHILADELPHIA, PENNSYLVANIA, U.S.A.

URL: <http://www.seas.upenn.edu/~amyers>

E-mail address: amyers@seas.upenn.edu