

Achieving Wireline Random Access Throughput in Wireless Networking via User Cooperation

Alejandro Ribeiro, Nikolaos. D. Sidiropoulos, Georgios. B. Giannakis, and Yingqun Yu

Abstract—Well appreciated at the physical layer, user cooperation is introduced here as a diversity enabler for wireless random access (RA) at the medium access control sub-layer. This is accomplished through a two-phase protocol in which active users start with a low power transmission attempting to reach nearby users and follow up with a high power transmission in cooperation with the users recruited in the first phase. We show that such a cooperative protocol yields a significant increase in throughput. Specifically, we prove that for networks with a large number of users, the throughput of a cooperative wireless RA network operating over Rayleigh fading links approaches the throughput of an RA network operating over additive white Gaussian noise links - thus justifying the title of the paper. The message borne out of this result is that user cooperation offers a viable choice for migrating diversity benefits to the wireless RA regime, thus bridging the gap to wireline RA networks, without incurring a bandwidth or energy penalty.

Keywords: Random Access, User Cooperation, Fading Channels

I. INTRODUCTION

Offering well-documented counter-measures against fading, diversity techniques find widespread applications in modern wireless systems. Such techniques capitalize on natural phenomena, e.g., the exploitation of multipath diversity in Direct Sequence (DS) Spread Spectrum (SS) channels [7], to receive/transmit antenna arrays [3], which require expensive additional radio frequency (RF) components (separate transmit/receive RF chains). User cooperation is a recently introduced diversity technique in which many single-antenna users share their information to construct a distributed virtual antenna array – an idea that has gained rapid acceptance as a sensible compromise between dependability and deployment cost [21], [22]. User-collaborative diversity in *fixed access* point to point links is by now well understood (see e.g., [9]). Recent works have also pursued user cooperation in multiple access channels [17], [20]. Particularly relevant to the present

Part of the results in this paper appeared in [18]. Manuscript received April 28, 2005; revised April 14, 2006 and September 6, 2006; accepted October 20, 2006. The editor coordinating the review of this paper and approving it for publication is Prof. Eytan Modiano. Work in this paper was prepared through collaborative participation in the Communications and Networks Consortium sponsored by the U. S. Army Research Laboratory under the Collaborative Technology Alliance Program, Cooperative Agreement DAAD19-01-2-0011. The U. S. Government is authorized to reproduce and distribute reprints for Government purposes notwithstanding any copyright notation thereon. The work of N. D. Sidiropoulos was partially supported by a bilateral cooperative research grant of the Greek Secretariat for Research and Technology.

The authors are with the Dept. of Electrical and Computer Engineering, University of Minnesota, 200 Union Street SE, Minneapolis, MN 55455. Tel/fax: (612)626-7781/625-4583. Email: {aribeiro, georgios, yyu}@ece.umn.edu.

N. D. Sidiropoulos is with the Dept. of Electrical and Computer Engineering, Technical University of Crete, Chania - Crete, Greece 731 00. Tel/fax: +30-28210-37227/+30-8210-37542. Email: nikos@telecom.tuc.gr.

work is the notion that spatial separation in multiple access channels allows the use of a shared channel for peer-to-peer communications whereby “good reception” opportunities of nearby idle users are exploited [20].

In the present paper, we introduce user cooperation in *random access* (RA) channels by drawing from two different sources. On the one hand, we draw from well-established spread spectrum random access (SSRA) protocols; see e.g., [2], [8], [13] and references therein. And on the other hand, we draw from the observation that user cooperation can be viewed as a form of multipath, a type of diversity for which SS with long PN sequences used as spreading codes is particularly well suited [17].

An intuitive notion underlying the main results of this paper is that user cooperation is a form of diversity well matched to the very nature of RA networks. Indeed, the random nature of RA dictates that at any given time only a fraction of potential users is active, the others having either empty queues or their transmissions deferred. Accordingly, given that only a few out of the total number of transmitters are active at any given time, transmission hardware resources are inherently under-utilized in wireless RA networks. As we will show, user cooperation can exploit these resources to gain a diversity advantage, without draining additional energy from the network and without bandwidth expansion. Reinforcing this intuitively reasonable notion, the number of temporarily idle users increases with the size of the network, indicating that user cooperation is available when most needed; i.e., in congested heavily-populated networks. While intuitive notions not always turn out to be true, this one will; the main purpose of this paper being precisely to establish that as the network size increases, there is an increasing diversity advantage to be exploited leading to a limiting scenario in which *the throughput of cooperative RA over wireless fading channels approaches that of an equivalent system operating over an additive white Gaussian noise (AWGN) channel*.

Building on an existing network diversity multi-access (NDMA) protocol [23], cooperative RA has been also considered in [10], [27], [11], where re-transmitting cooperators aid the separation of multiple collided packets. However, NDMA-based schemes are known to be challenged by channel ill-conditioning, difficulty in determining the number of collided packets and relatively high complexity at the access point as well as at the relays, which require analog (waveform storage and) forwarding [10], [27], [11].

The rest of the paper is organized as follows. The spatial distribution of users and the physical propagation model are introduced in Section II to formalize the notion that cooperation takes place among nearby users. In Section II-A, we provide

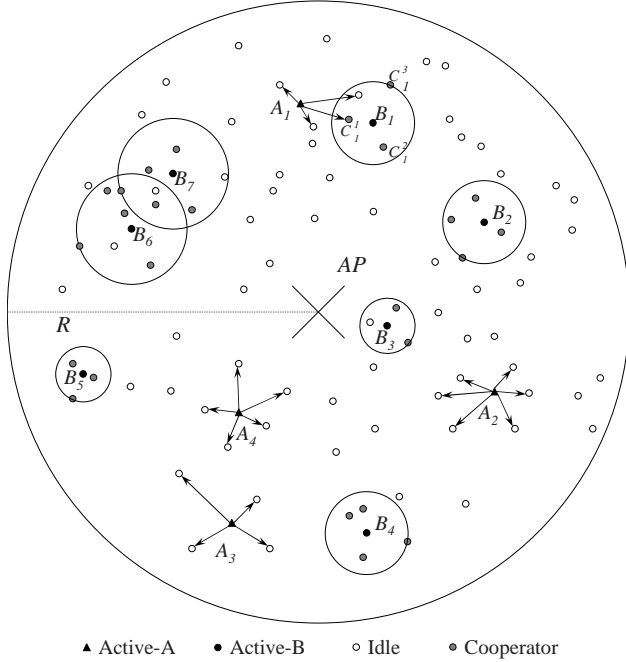

Fig. 1. A snapshot of a cooperative RA network. Users are divided into four classes: Active-A users trying to reach nearby idle users, Active-B users trying to reach the AP, Idle users that have empty queues or deferred their transmissions, and Cooperators that are helping Active-B users in reaching the AP.

a high level description of how our cooperative RA protocol operates and explain different user states that emerge due to cooperation. We then introduce in Section III a novel non-cooperative SSRA protocol upon which a cooperative version is built later on. The throughput of this protocol is analyzed in Section III-A to serve as a benchmark as well as to illustrate the tools utilized. A consequence of this analysis, discussed in Section III-B, is to motivate the beneficial role of diversity by showing how it can close the large throughput gap between corresponding systems operating over wireless and wireline channels.

Having made the case for diversity, we argue about a symbiotic relation between RA and user cooperation and introduce in Section IV our Opportunistic Cooperative Random Access (OCRA) protocol based on the opportunistic exploitation of highly reliable links among neighboring users. We then move on to study its throughput in Section V and introduce our main results regarding OCRA's asymptotic throughput as the number of users grows large in Section V-A. Section V-A contains only the most relevant results, with a more detailed asymptotic behavior analysis postponed to Section VI, where we show how pertinent theorems formalize intuitive comments made in this introduction about the suitability of user cooperation as the form of diversity for RA networks. Finally, synchronization issues motivate an unslotted counterpart of OCRA that we present in Section VII. Simulations corroborating our theoretical results are presented in Section VIII, and Section IX concludes the paper.

II. PRELIMINARIES

The problem addressed in this paper is that of designing a cooperative RA protocol. Consider a set of J users, $\mathcal{J} = \{U_j\}_{j=1}^J$, communicating with an access point (AP) in a wireless RA network as depicted in Fig. 1. User j and its position in a coordinate system centered at the AP will be denoted by U_j . With these positions considered random and uniformly distributed within a circle of radius R , we express the probability of U_j to have distance from the AP smaller than r as

$$\Pr\{\|U_j\| < r\} = \frac{r^2}{R^2}, \quad 0 \leq r \leq R, \quad (1)$$

where $\|U_j\|$ denotes the 2-norm of the position vector U_j . User positions are further assumed independent.

Users transmit blocks of duration T with U_j 's block denoted as $\mathbf{x}_{U_j} := \{x_{U_j}(t)\}_{t=0}^{T-1}$. The broadcast nature of the wireless channel dictates that the signal $\mathbf{z}_{U_{j_1}} = \{z_{U_{j_1}}(t)\}_{t=0}^{T-1}$ received at any point is the superposition of all users' signals, $\{\mathbf{x}_{U_{j_2}}\}_{j_2=1}^J$; i.e.,

$$\mathbf{z}_{U_{j_1}} = \sum_{j_2=1}^J h(U_{j_2}, U_{j_1}) \mathbf{x}_{U_{j_2}} + \mathbf{n}, \quad (2)$$

where $\mathbf{n} := \{n(t)\}_{t=0}^{T-1}$ is zero-mean additive white Gaussian noise (AWGN) with variance $\mathbb{E}[n^2(t)] = N_0$, and $h(U_{j_2}, U_{j_1})$ denotes the Rayleigh block fading channel coefficient corresponding to the link $U_{j_2} \rightarrow U_{j_1}$. When $U_{j_1} \equiv AP$ we will denote $z_{AP}(t) \equiv z(t)$ and $h(U_{j_2}, AP) \equiv h(U_{j_2})$.

The average power received at U_{j_1} from a source U_{j_2} transmitting with power $P(U_{j_2})$ adheres to an exponential path loss model

$$P(U_{j_2} \rightarrow U_{j_1}) = \frac{\xi P(U_{j_2})}{\|U_{j_1} - U_{j_2}\|^\alpha}, \quad (3)$$

with ξ and $\alpha \geq 2$ denoting the pathloss constant and exponent respectively [16, Chap.3]. As a special case, the power received at the AP from U_{j_2} is $P(U_{j_2} \rightarrow AP) = \xi P(U_{j_2}) / \|U_{j_2}\|^\alpha$. Consistent with (3), the Rayleigh block fading coefficient $h(U_{j_1}, U_{j_2})$ in (2) is complex Gaussian distributed with zero-mean and variance

$$\begin{aligned} \text{var}[h(U_{j_1}, U_{j_2})] &:= \mathbb{E}[h(U_{j_1}, U_{j_2})h^*(U_{j_1}, U_{j_2})] \\ &= \mathbb{E}[|h(U_{j_1}, U_{j_2})|^2] \\ &= \frac{\xi}{\|U_{j_1} - U_{j_2}\|^\alpha}. \end{aligned} \quad (4)$$

We assume that fading coefficients linking different users are uncorrelated and that channel state information is obtained by the receivers (e.g., using a training sequence) to permit coherent reception. We further note that block fading coefficients $h(U_{j_1}, U_{j_2})$ are constant for the duration of a transmission block but different and uncorrelated across blocks.

A. Two-phase cooperation

Transmission in the proposed cooperative RA protocol proceeds in two phases. In the first phase, "phase-A", the user sends a packet with sufficient power to be correctly decoded

by nearby peers; while in the second phase, “phase-B”, the set of peers that successfully decoded this packet transmit cooperatively with power sufficient to reach the AP. If we manage to balance conflicting power requirements, what will happen in phase-A is that nearby users decode the original packet while the power received at the destination is negligible. On the one hand, this implies that phase-A users do not interfere severely with nodes which are at the same time operating in phase-B. On the other hand, phase-A succeeds in locally disseminating information so that subsequent phase-B transmissions are enriched with a certain degree of user cooperation diversity.

It is not necessary to follow a given user from phase-A to phase-B, because what will happen to current phase-A users when they reach phase-B is statistically indistinguishable from what is happening to current phase-B users. It thus suffices to study a snapshot of the RA network which comprises current phase-A and phase-B users. At this given snapshot, the set of users \mathcal{J} is temporarily divided into a set of N_A “active-A” users, $\mathcal{A} = \{A_j\}_{j=1}^{N_A}$, operating in phase-A of their transmission trying to reach nearby users; a set of N_B active-B users, $\mathcal{B} = \{B_j\}_{j=1}^{N_B}$, communicating their packets to the AP; and N_I idle users $\mathcal{I} = \{I_j\}_{j=1}^{N_I}$ that either have empty queues or decided not to transmit. Clearly, we have that $\mathcal{J} = \mathcal{A} \cup \mathcal{B} \cup \mathcal{I}$. A fourth class of users, encompasses the sets of cooperators $\mathcal{C}_j = \{C_j^k\}_{k=0}^{K_j}$ associated with each active-B user B_j . The set \mathcal{C}_j contains the K_j users that correctly decoded B_j 's phase-A packet in the previous slot, and we adopt the convention that $C_j^0 = B_j$.

Remark 1 It is worth stressing that the different sets of users are not necessarily mutually exclusive. Actually, the sole constraint on the classes is

$$\mathcal{I} \cap (\mathcal{B} \cup \mathcal{A}) = \emptyset, \quad (5)$$

meaning that a terminal cannot be idle and active-A or active-B at the same time, but is allowed to be active-A and active-B in the same slot, as we will detail later. Also, it is convenient to regard cooperators as a parallel class in the sense that

$$\mathcal{C}_j \subseteq \mathcal{I} \cup \mathcal{A}, \quad (6)$$

implying that a cooperator is either regarded as active-A, if it independently decided to transmit its own information, or as idle, if it did not. The reason for these requirements will become clear in Section IV.

It will turn out, that phase-A will be the phase determining the system's performance; a perhaps intuitive result since it is in this phase that the need arises to balance the conflicting requirements of transmitting with as low power as possible while reaching as many idle users as possible. To this end, we will isolate one of the statistically identical phase-A user nodes, call it $U_0 \in \mathcal{A}$, and study the tradeoff between phase-A power and number of idle users reached. Without loss of generality, we further assume that $U_0 = A_{N_A}$. Let $\mathcal{C}_0 = \{C_0^k\}_{k=0}^{K_0}$ denote the set of (idle) users that successfully decode U_0 's phase-A packet with the convention that $C_0^0 = U_0$. Note

that the nodes in the set \mathcal{C}_0 are not cooperating with U_0 in the current slot, but will do so in the next one.

The key to delineate the aforementioned power tradeoff is to observe that the closer an idle node is to U_0 the larger is the probability of decoding U_0 's active-A packet correctly. Consequently, we will consider distance-ordered sets with $I_0^{(k)}$, $A_0^{(k)}$ and $B_0^{(k)}$ denoting the k^{th} closest to U_0 , idle, active-A and active-B user respectively¹; i.e.,

$$\|I_0^{(1)} - U_0\| \leq \|I_0^{(2)} - U_0\| \leq \dots \leq \|I_0^{(k)} - U_0\|, \quad (7)$$

$$I_0^{(1)} \dots I_0^{(k)} \in \mathcal{I},$$

with similar expressions holding true for active-A and active-B users. Likewise, we will order the sets of cooperators according to their distance from the active-B user they are cooperating with

$$0 = \|C_j^{(0)} - B_j\| \leq \|C_j^{(1)} - B_j\| \leq \dots \leq \|C_j^{(K_j)} - B_j\|, \quad j \in [1, N_B] \quad (8)$$

where the first equality follows from the convention $C_j^{(0)} = B_j$.

Note that consistent with the random nature of RA networks, the degree of cooperation K_j that each U_j receives is itself random, not requiring pre-established agreement among users. Cooperative RA throughput will be determined by the statistics of K_j , the characterization of which constitutes a central topic of this paper.

III. NON-COOPERATIVE SS RANDOM ACCESS

In this section, we present a non-cooperative spread spectrum (SS) RA protocol upon which we will build the cooperative version in Section IV. While many such non-cooperative SSRA systems have been proposed and analyzed in the literature (see e.g., [2], [8], [13] and references therein) we summarize here the one introduced in [28] that we regard as the best starting point for our cooperative protocol in Section IV. The queue model is depicted in Fig. 2, where each of the J users has an infinite-length buffer for storing L -bit fixed length packets that arrive at a rate of λ packets per packet duration. The packet arrival processes are identically distributed (i.d.), not necessarily independent, yielding a total arrival rate of $J\lambda$ packets per packet duration.

The L bits of each packet are spread by a factor S (a.k.a. spreading gain) to construct a transmitted packet of $T := SL$ chips. Spreading is implemented using a long pseudo-noise (PN) sequence $\mathbf{c} := \{c(t)\}_{t \in \mathbb{Z}}$ with period $\mathcal{P} = SL = T$. Letting $\mathbf{d}_{U_j} := \{d_{U_j}(l)\}_{l=0}^{L-1}$ denote a *data* packet of user U_j , and $\mathbf{x}_{U_j} := \{x_{U_j}(t)\}_{t=0}^{T-1}$ the corresponding *transmitted* packet, we have

$$x_{U_j}(Sl + s) = \sqrt{P(U_j)} d_{U_j}(l) c(Sl + s - \tau_{U_j}), \quad (9)$$

$$l \in [0, L - 1], \quad s \in [0, S - 1],$$

where we note that \mathbf{c} is a common long PN sequence *shared* by all users, τ_{U_j} is a user-specific shift applied to \mathbf{c} , and $P(U_j)$ is the power transmitted by node U_j .

¹Subscripts and superscripts in parentheses will henceforth signify ordering.

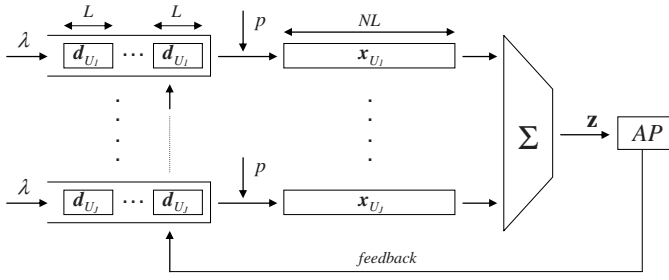

Fig. 2. Queue and transmission diagram of a non-cooperative SSRA network. Packets are spread using random shifts of a common long PN sequence.

These spread packets are transmitted to the AP, which acknowledges successfully decoded packets through a common feedback channel. As in [2], [8] and [13] feedback is assumed to be instantaneous and free of errors.

We are now ready to define the non-cooperative SSRA protocol considered in this paper by the following rules:

[R1] Time is divided into slots, each comprising T chip periods. If users decide to transmit, they do so at the beginning of a slot.

[R2] Packets are spread for transmission according to (9). The shift τ_{U_j} is selected at random by each user; and $P(U_j) = P_0 \|U_j\|^\alpha / \xi$ effects average power control so that all users are received at the AP with the same average power P_0 [c.f. (3)].

[R3] If a given user's queue is not empty, the user transmits the first queued packet in the next slot with probability p .

Rule [R1] defines a slotted system and its purpose is to simplify throughput analysis; [R2] effects statistical user separation and power control; and [R3] controls the transmission rate, with p adjusted so as to maximize throughput.

To better appreciate [R2], let $N \leq J$ denote the number of users active in a given slot and consider the block $\mathbf{z} := \{z(t)\}_{t=0}^{T-1}$ received at the AP. Specializing (2) to the superposition of these N transmissions, the received chips (entries of \mathbf{z}) are

$$z(Sl+s) = \sum_{j=1}^N \sqrt{P(U_j)} h(U_j) d_{U_j}(l) c(Sl+s-\tau_{U_j}) + n(Sl+s). \quad (10)$$

To recover packets from a given user, say U_N without loss of generality, we compensate the random phase by multiplying with the normalized channel conjugate $h_n^*(U_N) := h^*(U_N)/|h(U_N)|$ and despread \mathbf{z} using the properly delayed version of the long PN sequence $\mathbf{c}(t - \tau_{U_N})$. The resultant decision vector $\mathbf{r}_{U_N} := \{r_{U_N}(l)\}_{l=0}^{L-1}$ has entries

$$r_{U_N}(l) = \frac{h_n^*(U_N)}{S} \sum_{s=0}^{S-1} z(Sl+s) c(Sl+s-\tau_{U_N}) \quad (11)$$

$$= \sqrt{P(U_N)} |h(U_N)| d_{U_N}(l) + \sum_{j=1}^{N-1} \mathbb{I}(l; U_N \rightarrow AP; U_j) + \tilde{n}(l)$$

where we used $h(U_N) h_n^*(U_N) \equiv |h(U_N)|$. Note that the noise variance is reduced by S ; i.e., $\text{var}[\tilde{n}(l)] = N_0/S$, and

interference terms emerge due to users $\{U_j\}_{j=1}^{N-1}$; the symbol $\mathbb{I}(l; U_{j_0} \rightarrow AP; U_j)$ denotes the interference of user U_j to the communication of bit l from U_N to the AP, and is given by

$$\mathbb{I}(l; U_N \rightarrow AP; U_j) = \frac{1}{S} \sqrt{P(U_j)} h(U_j) h_n^*(U_N) d_{U_j}(l) \times \sum_{s=0}^{S-1} c(Sl+s-\tau_{U_j}) c(Sl+s-\tau_{U_N}). \quad (12)$$

The most important property of PN sequences is that they have a white-noise like autocorrelation $\mathbb{E}[c(t - \tau_{U_j}) c(t - \tau_{U_N})] \approx \delta(\tau_{U_j} - \tau_{U_N})$, from where we deduce that if $\tau_{U_j} \neq \tau_{U_N}$, then

$$\mathbb{E}[\mathbb{I}(l; U_N \rightarrow AP; U_j)] = 0 \quad (13)$$

$$\text{var}[\mathbb{I}(l; U_N \rightarrow AP; U_j)] = P_0/S \quad (14)$$

$$\mathbb{E}[\mathbb{I}(l; U_N \rightarrow AP; U_{j_1}) \mathbb{I}^*(l; U_N \rightarrow AP; U_{j_2})] = 0, \quad \forall j_1 \neq j_2 \quad (15)$$

where in deriving the last equality we also exploited the independence of users' fading coefficients when $\tau_{U_{j_1}} = \tau_{U_{j_2}}$.

Combining (11) with (13), we find readily that the expected value of the decision vector is

$$\mathbb{E}[r_{U_N}(l)] = \sqrt{P(U_N)} |h(U_N)| d_{U_N}(l) \quad l \in [0, L-1], \quad (16)$$

from where it follows that a suitable demodulator is $\hat{\mathbf{d}}_{U_{j_0}} = \text{sign}(\mathbf{r}_{U_{j_0}})$. The interference increases the variance of the decision variable $r_{U_N}(l)$ in (11), which after using properties (14) and (15) turns out to be

$$\text{var}[r_{U_N}(l)] = N_0/S + P_0(N-1)/S, \quad l \in [0, L-1]. \quad (17)$$

Eq. (17) implies that the interference increases the probability of error because it increases the variance of the decision statistic. As in e.g., [25, Chap.2] we can model the interference as Gaussian and independent for different bits, implying that the probability that a packet is correctly decoded is fully determined by the signal to interference-plus-noise ratio (SINR). When N users are active, the instantaneous SINR is [c.f. (16) and (17)]

$$\gamma_N := \frac{\mathbb{E}^2[r_{U_N}(l)]}{\text{var}[r_{U_N}(l)]} = S \frac{P(U_N) |h(U_N)|^2}{N_0 + (N-1)P_0}, \quad (18)$$

and the average SINR is found by taking expected values with respect to the channel distribution [c.f. (18)]

$$\bar{\gamma}_N := \mathbb{E}[\gamma_N] = \frac{S}{N_0/P_0 + N - 1}, \quad (19)$$

where we used that $P(U_N) \mathbb{E}[|h(U_N)|^2] = P_0$ which follows from the average power control in [R2] and the channel model in (3).

We established in (16) that through [R2] we effect statistical separation of different users' packets, with packet error probability (PEP) determined by the SINR in (19). Notice though, that there is also a chance to have $\tau_{U_j} = \tau_{U_N}$ for some $j \neq N$. Both this and the interference term will determine the throughput of this non-cooperative RA protocol, motivating a distinction between what we term soft and hard collisions which we define as follows.

Definition 1 (Soft and hard collisions)

[a] We say that U_{j_0} experiences a “hard collision” (HC) if $\tau_{U_{j_0}} = \tau_{U_j}$ for some $j \neq j_0$; the HC event is

$$\text{HC}(U_{j_0}) := \bigcup_{j \neq j_0} \{\tau_{U_{j_0}} = \tau_{U_j}\}. \quad (20)$$

[b] Given that U_{j_0} does not experience a hard collision, we say that it experiences a “soft collision” (SC) when the packet is lost due to interference:

$$\text{SC}(U_{j_0}) := \{\hat{\mathbf{d}}_{U_{j_0}} \neq \mathbf{d}_{U_{j_0}} \mid \text{HC}^c(U_{j_0})\}, \quad (21)$$

where $\text{HC}^c(U_{j_0})$ denotes the complement of $\text{HC}(U_{j_0})$.

Conditioned on the number of active users N , we can evaluate the probability that U_{j_0} experiences a HC as the probability that any of the $N - 1$ interferers chooses the same PN shift

$$\begin{aligned} P_{\text{HC}}(N) &:= \Pr\{\text{HC}(U_{j_0}) \mid N\} = 1 - \Pr\{\text{HC}^c(U_{j_0}) \mid N\} \\ &= 1 - \left(1 - \frac{1}{T}\right)^{N-1}, \end{aligned} \quad (22)$$

where we used that since there are T possible PN shifts, $\Pr\{\tau_{U_{j_0}} = \tau_{U_j}\} = 1/T$. Likewise, the SC probability $P_{\text{SC}}(N)$ can be inferred from the SINRs in (18) and (19). For a given channel realization $h(U_N)$, $P_{\text{SC}}(N)$ is a function of the instantaneous SINR in (18); however, what matters from a throughput perspective is $P_{\text{SC}}(N)$ averaged over all channel realizations. We thus write

$$P_{\text{SC}}(N) := \Pr\{\text{SC} \mid N\} = P_e(\bar{\gamma}_N)[1 - P_{\text{HC}}(N)], \quad (23)$$

where $P_e(\bar{\gamma}_N)$ is a function that maps the link *average* SINR, $\bar{\gamma}_N$, to the *average* PEP. The function $P_e(\bar{\gamma}_N)$ is determined by the channel model and the transmission/reception parameters which include the type of modulation, type of receiver and forward error correcting (FEC) code. The existence of $P_e(\bar{\gamma}_N)$ is guaranteed since we model the interference as Gaussian and independent across bits. In fact, given Rayleigh interferers $P_e(\bar{\gamma}_N)$ is also a function of N , S and P_0/N_0 as clarified in Remark 3.

A packet is successfully decoded if and only if it neither experiences a hard collision, nor a soft one. Accordingly, the packet success probability with N active users ($N - 1$ interferers) is

$$P_s(N) := 1 - P_{\text{HC}} - P_{\text{SC}} = \left(1 - \frac{1}{T}\right)^{N-1} [1 - P_e(\bar{\gamma}_N)]. \quad (24)$$

The throughput of this non-cooperative SSRA system can be obtained from (24) as we analyze in the next section.

A. Throughput Analysis

A possible performance measure of RA networks is the average departure rate μ ; if we let $P_s = \sum_{n=1}^J \Pr\{N = n\} P_s(n)$ be the probability that a packet transmitted by the reference user U_{j_0} is successfully decoded by the AP, then

$$\mu = pP_s. \quad (25)$$

However, throughput instead of departure rate is the standard metric whose definition follows from the concept of stability.

We let $q_j(m)$ be the number of packets in U_j 's queue in the m^{th} slot, and say that this queue is stable if, [12]

$$\lim_{m \rightarrow \infty} \Pr\{q_j(m) \leq x\} = \mathbf{Q}(x) \quad \text{with} \quad \lim_{x \rightarrow \infty} \mathbf{Q}(x) = 1. \quad (26)$$

The conditions in (26) assert that the system is stable if and only if there exists a positive probability mass function of $\{q_j(m)\}_{j=1}^J$ when $m \rightarrow \infty$. A system is called stable if all the queues are stable, and throughput is defined as follows:

Definition 2 The maximum aggregate throughput is defined as the unique quantity η such that the system is stable if $J\lambda < \eta$ and unstable if $J\lambda > \eta$.

Thus, η is defined as the maximum aggregate arrival rate that the system can afford with stable queues. If $J\lambda < \eta$, then individual queues have a bounded number of packets and the packets get transmitted with finite delay. If $J\lambda > \eta$, then the queues grow without limit and the packets experience infinite delays.

The system will be clearly unstable if $\lambda > \mu$. Accordingly, the throughput cannot exceed the departure rate $\eta \leq J\mu$. What is not so obvious is whether $\lambda < \mu$ yields a stable system. Indeed, this is not true in general but for symmetric and stationary systems it is true due to Loynes' theorem [12]. For this subclass of systems, we thus have

$$\eta = J\mu. \quad (27)$$

A challenge with the protocol defined by rules [R1]-[R3] is that the service processes are not necessarily stationary due to the possibility of having empty queues. Notwithstanding, by resorting to a dominant system approach, [24], and following an equivalence argument (see [5], [15]), we can establish that $\eta = J\mu$ for the SSRA protocol introduced in Section III to obtain the following proposition.

Proposition 1 Consider the protocol defined by rules [R1]-[R3], and not necessarily independent but i.i.d. arrival processes with rate λ . Then, the average aggregate throughput is

$$\eta = \eta(J, N_0/P_0, S, p) \quad (28)$$

$$:= Jp \sum_{n=0}^{J-1} \binom{J-1}{n} p^n (1-p)^{J-1-n} \left(1 - \frac{1}{T}\right)^n [1 - P_e(\bar{\gamma}_{n+1})]$$

with $\bar{\gamma}_{n+1} := 1/(N_0/P_0 + n/S)$.

Proof: Define the dominant system by replacing rule [R3] with:

[R3'] Users transmit with probability p . If a user's queue is empty, then the corresponding user transmits a dummy packet.

Rule [R3'] is commonly used to decouple the different users' queues. But here we are interested in the fact that it renders the system stationary and allows application of Loynes' theorem. Thus, using (27) for the dominant system we have

$$\eta_{DS} = J\mu = JpP_s, \quad (29)$$

with η_{DS} denoting the dominant system's throughput.

To compute P_s , we condition on the number of *interfering* users $N - 1$ to obtain

$$\begin{aligned} P_s &= \sum_{n=0}^{J-1} \Pr\{N - 1 = n\} P_s(n + 1) \\ &= \sum_{n=0}^{J-1} \Pr\{N - 1 = n\} \left(1 - \frac{1}{T}\right)^n [1 - P_e(\bar{\gamma}_{n+1})], \end{aligned} \quad (30)$$

where the limits of the summation are because the number of interferers is between 0 and $J - 1$, and the second equality follows from (24) with $N - 1 = n$.

On the other hand, since interferers act independently $N - 1$ follows a binomial distribution with parameters p and $J - 1$ and accordingly $\Pr\{N - 1 = n\} = \binom{J-1}{n} p^n (1 - p)^{J-1-n}$, which upon substitution into (30) yields

$$P_s = \sum_{n=0}^{J-1} \binom{J-1}{n} p^n (1-p)^{J-1-n} \left(1 - \frac{1}{T}\right)^n [1 - P_e(\bar{\gamma}_{n+1})]. \quad (31)$$

Furthermore, substituting (31) into (29) yields (28) and establishes the result for the dominant system defined by rules [R1], [R2] and [R3'].

We can now repeat the argument in [5], for what we consider identical instantiations of the arrival processes fed to the dominant and original systems. Given that we are adding (dummy) packets, the queues in the fictitious dominant system can never be shorter than the queues in the original system. It follows that if the dominant system is stable, then so must be the original system; hence $\eta \geq \eta_{DS}$. Assume now that $\eta > \eta_{DS}$ strictly, to infer that there exists an arrival rate $\eta > \lambda J > \eta_{DS}$ that makes the original system stable and the dominant system unstable. But this is a contradiction since if the dominant system were unstable, there would be no long-term need for dummy packets since all the queues in the dominant system would eventually become continuously backlogged with real packets. The dominant system is therefore equivalent to the original system; hence, the original system is also unstable. So, we must have $\eta = \eta_{DS}$, and (28) is also valid for the original system defined by rules [R1]-[R3]. ■

Note that η in (28) is a function of the number of users J , the noise to signal ratio N_0/P_0 , the spreading gain S and the transmission probability p . We are usually interested in the maximum stable throughput (MST) defined as

$$\eta_{\max}(J, N_0/P_0, S) = \max_p \{\eta(J, N_0/P_0, S, p)\}, \quad (32)$$

and achieved at $p = p_{\max}$. In this particular work, we will be interested in the asymptotic MST that we define as

$$\eta_{\infty}(N_0/P_0, S) = \lim_{J \rightarrow \infty} \eta_{\max}(J, N_0/P_0, S), \quad (33)$$

and interpret as the average number of packets transmitted per unit time in a system with a very large number of users.

In Section V, we will compare η_{∞} for the SSRA protocol introduced in this section against a suitably defined cooperative RA protocol. Before moving on to that, let us show what advantage diversity has to offer in RA systems.

B. On the role of diversity in RA

For this section only, we consider different models for the channels $h(U_j)$ and present a motivating example of the function $P_e(\bar{\gamma}_N)$. Let us suppose that we use BPSK modulation with coherent detection and code the packet with a BCH block code capable of correcting up to ϵ_{\max} errors. With $Q(x) := (1/\sqrt{2\pi}) \int_x^{\infty} e^{-u^2/2} du$ denoting the Gaussian tail function and recalling the Gaussian model of interference, the bit error probability with γ_N instantaneous SINR is $q(\gamma_N) = Q(\sqrt{2\gamma_N})$ [14, sec. 5.2] and the corresponding *instantaneous* PEP is given by [14, p.437]

$$P_{e,i}(\gamma_N) = 1 - \sum_{\epsilon=0}^{\epsilon_{\max}} \binom{L}{\epsilon} q^{\epsilon}(\gamma_N) [1 - q(\gamma_N)]^{L-\epsilon}. \quad (34)$$

It is interesting to compare the throughput as determined by (28) for different channel models. The best possible scenario is when $h(U_j)$ is a deterministic constant (AWGN channel), in which case $\gamma_N = \bar{\gamma}_N$ and the corresponding average PEP is thus $P_e^G(\bar{\gamma}_N) = P_{e,i}(\gamma_N)$.

A better model for the wireless environment however, is a Rayleigh fading channel where γ_N is random Rayleigh distributed (since $|h(U_j)|^2$ is). In this case, we have to average (34) over the channel (Rayleigh) distribution $f_{\gamma_N}(\gamma_N)$ to obtain

$$P_e^R(\bar{\gamma}_N) = \int_0^{\infty} P_e(\gamma_N) f_{\gamma_N}(\gamma_N) d\gamma_N. \quad (35)$$

It can be easily verified that for moderate and large $\bar{\gamma}_N$ we have $P_e^R(\bar{\gamma}_N) \gg P_e^G(\bar{\gamma}_N)$, ultimately leading to a much smaller throughput when otherwise equivalent systems operate over Rayleigh channels than when they operate over AWGN channels.

The throughput over wireless channels can be increased with diversity techniques, e.g., multiple transmit antennas. Consider a terminal with κ antennas transmitting a packet as in (9) using a user and antenna-specific $\tau_{U_j, \kappa}$ so that despreading \mathbf{z} in (10) with $\mathbf{c}(t - \tau_{U_j, \kappa})$ recovers the signal transmitted by U_j 's κ^{th} antenna. This way the AP can decode κ copies received through uncorrelated Rayleigh channels, $\{h_k(U_j)\}_{k=1}^{\kappa}$, yielding the aggregate channel model $|h(U_j)|^2 := \sum_{k=1}^{\kappa} |h_k(U_j)|^2$ when maximum ratio combining is used. If we let the uncorrelated channels have equal average received powers so that $P(U_j)E[|h_k(U_j)|^2] = P_0/\kappa$, the channel distribution $f_{\gamma_N}(\gamma_N)$ is chi-square with 2κ degrees of freedom. To fully characterize this distribution we repeat steps (11) - (19) to obtain the per-path average SINR

$$\bar{\gamma}(N, \kappa) := S \frac{1/\kappa}{N_0/P_0 + N - 1 + (\kappa - 1)/\kappa}, \quad (36)$$

where in the denominator, the term N_0/P_0 comes from the AWGN, the term $N - 1$ from the interference from other terminals and the term $(\kappa - 1)/\kappa$ from the (self-)interference of the remaining $\kappa - 1$ paths of the same terminal. The corresponding aggregate SINR is given by $\bar{\gamma}_N := \kappa \bar{\gamma}(N, \kappa)$ and the average PEP $P_e^{\kappa}(\bar{\gamma}_N)$ can be found from (35) with $f_{\gamma_N}(\gamma_N)$ modified accordingly [14, sec. 14.4].

A particularly important fact for the present work is that if $\kappa \rightarrow \infty$ in the κ -order diversity channel, then the channel

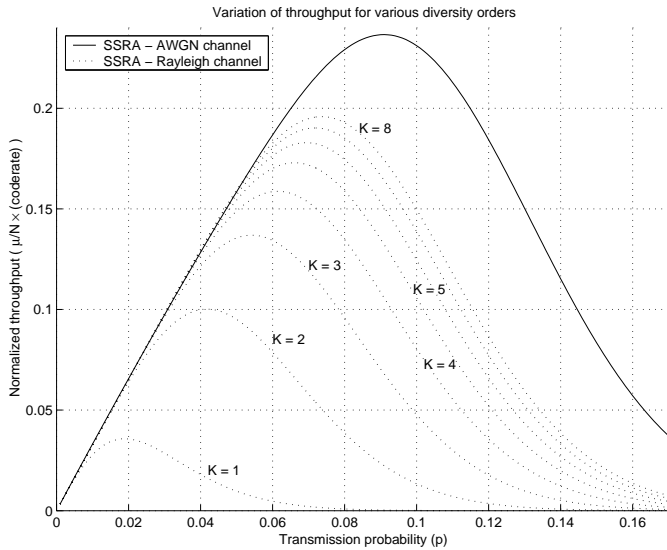

Fig. 3. High-order diversity closes the enormous gap between the performance of RA over wireless Rayleigh fading channels with respect to wireline AWGN channels ($J = 128$, $S = 32$, $L = 1024$, $215/255$ BCH code capable of correcting $t = 5$ errors).

$|h(U_j)|^2$ approaches an AWGN channel. Indeed,

$$\lim_{\kappa \rightarrow \infty} P(U_j) |h(U_j)|^2 = \lim_{\kappa \rightarrow \infty} \kappa \frac{1}{\kappa} \sum_{k=1}^{\kappa} P(U_j) |h_k(U_j)|^2 = P_0, \quad (37)$$

where the limit follows from $E[|h_k(U_j)|^2] = P_0/\kappa$ and the strong law of large numbers. But (37) implies that $|h(U_j)|^2$ converges to a constant which by definition leads to an AWGN channel. We can now take the limit in (36) to obtain

$$\lim_{\kappa \rightarrow \infty} \kappa \bar{\gamma}(N, \kappa) = \frac{S}{N_0/P_0 + N} = \bar{\gamma}_{N+1}. \quad (38)$$

And combine (38) with (37) to claim that as the diversity order $\kappa \rightarrow \infty$, the PEP $P_e^\infty(\bar{\gamma}_N) := \lim_{\kappa \rightarrow \infty} P_e^\kappa(\bar{\gamma}_N)$ of this ∞ -order diversity channel approaches the PEP of a Gaussian channel with a (in most cases small) increase in SINR; i.e., $P_e^\infty(\bar{\gamma}_N) = P_e^G(\bar{\gamma}_{N+1})$.

For each of the channels considered, we depict in Fig. 3 the normalized throughput as a function of the transmission probability p . It comes as no surprise that the MST over a wireless (Rayleigh) channel is miserable, being almost an order of magnitude smaller than the MST of the wireline AWGN channel. Corroborating the implications of (37), this sizeable gap can be closed by diversity techniques, as hinted by the twofold increase observed with 2-order diversity and the close-to-AWGN MST enabled with 8-order diversity. We summarize this important observation in the following remark.

Remark 2 For a given ECC, let $\eta^G(J, N_0/P_0, S, p)$ and $\eta^\kappa(J, N_0/P_0, S, p)$ be the throughput over an AWGN channel and a κ -order diversity channel, respectively. Defining the throughput over an ∞ -order diversity channel as $\eta^\infty(J, N_0/P_0, S, p) := \lim_{\kappa \rightarrow \infty} \eta^\kappa(J, N_0/P_0, S, p)$ we can write [c.f. (19), (37) and (38)]

$$\eta^\infty(J, N_0/P_0, S, p) = \eta^G(J, N_0/P_0 + 1, S, p). \quad (39)$$

This also implies the same relation between MSTs and asymptotic MSTs, $\eta_\infty^\infty(N_0/P_0, S) = \eta_\infty^G(N_0/P_0 + 1, S)$, a fact that we will exploit later on in pertinent remarks. With the SNR before spreading being $N_0/P_0 \gg 1$ for usual values of SNR and S , we deduce that (39) entails almost identical throughputs.

To characterize the diversity advantage in the ensuing sections without resorting to a specific transmission/reception scheme, we introduce the following definition.

Definition 3 In the family of PEP functions $\{P_e^\kappa(\bar{\gamma}_N)\}_{\kappa \in \mathbb{N}}$, $P_e^\kappa(\bar{\gamma}_N)$ represents the PEP for a κ -order diversity channel when the SINR is $\bar{\gamma}_N := \kappa \bar{\gamma}(N, \kappa)$ with $\bar{\gamma}(N, \kappa)$ as in (36). Specifically, $P_e^\kappa(\bar{\gamma}_N)$ maps the average SINR to the average PEP for terminals with κ transmit antennas so that the information bearing signal is transmitted over κ independent Rayleigh channels $\{h_k(U_j)\}_{k=1}^{\kappa}$ with equal powers $P(U_j)h_k(U_j) = P_0/\kappa$ via user and antenna-specific PN delays $\tau_{U_j, \kappa}$.

An example of the family $\{P_e^\kappa(\bar{\gamma}_N)\}_{\kappa \in \mathbb{N}}$ is the one generated by BCH codes and described by (34) - (36). While in deriving these equations we used the Gaussian model of interference this assumption is not strictly necessary for our claims as we discuss in the following remark.

Remark 3 In deriving (17) we modelled the interference plus noise term $\sum_{j=1}^{N-1} \mathbb{I}(l; U_N \rightarrow AP; U_j) + \tilde{n}(l)$ in (11) as a Gaussian random variable independent for different values of l . This approximation was later used in this section to derive the PEP expressions (34) and (35). The Gaussian model of interference is often accurate in practice; more generally (and perhaps more importantly) though, Proposition 1 as well as other results derived in the ensuing sections are true regardless of this assumption. Indeed, what is relevant for our results is the existence of the family $\{P_e^\kappa(\bar{\gamma}_N)\}_{\kappa \in \mathbb{N}}$ in Definition 3. Clearly, $P_e^\kappa(\bar{\gamma}_N)$ can be defined in terms of the exact correlation of $\sum_{j=1}^{N-1} \mathbb{I}(l; U_N \rightarrow AP; U_j) + \tilde{n}(l)$ for different values of l . Note that if the interference plus noise is not modelled as independent for different bits l , P_e^κ depends on higher moments of the interference plus noise distribution and its characterization requires knowledge of N , S and P_0/N_0 . In our context of iid Rayleigh normalized channels, $P_e^\kappa(\bar{\gamma}_N)$ is in fact a function of only γ_N , N , S and P_0/N_0 . Since these three parameters are fixed throughout, we will write $P_e^\kappa(\bar{\gamma}_N)$ as a function of γ_N only and keep the rest implicit for brevity as in Definition 3. Also, even though the relation in (39) does not hold true without the Gaussian assumption, $P_e^\infty(\bar{\gamma}_N) = P_e^G(\bar{\gamma}_{N+1})$ still does. Moreover, as can be easily verified by simulations, $\eta^\infty(J, N_0/P_0, S, p) \approx \eta^G(J, N_0/P_0, S, p)$ as noted in Remark 2.

The present section has established that diversity offers the potential for a large throughput increase in RA networks; the point is, of course, whether and how this diversity can be enabled. This is the theme we deal with in the next section, where we explore the suitability of user cooperation to enable high order diversity in random access networks.

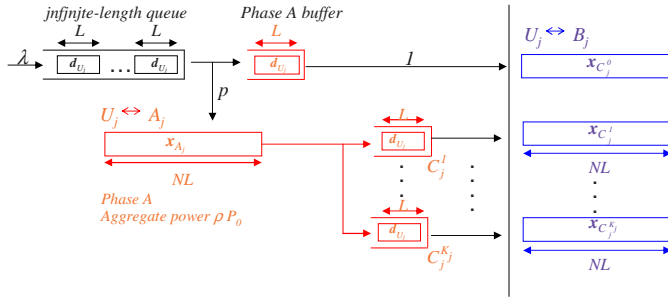

Fig. 4. OCRA is a two-phase cooperative protocol. During phase-A users transmit with small power trying to recruit idle users as cooperators for phase-B. The seemingly conflicting requirements of small ρ and large K turn out to be asymptotically compatible.

IV. OPPORTUNISTIC COOPERATIVE RANDOM ACCESS

Because users transmit at random in RA networks a number of users remain idle over any given slot. Moreover, the transmission probability p_{\max} that achieves MST decreases as J increases and the percentage of temporarily idle users that do not transmit in a given slot increases. This implies that a large number of potential cooperators (idle users) are available per active user and motivates user cooperation as a suitable diversity enabler for wireless RA.

Indeed, this large number of potential cooperators suggests a high probability of some of them having a good signal reception of any given user. The Opportunistic Cooperative Random Access (OCRA) protocol introduced in this section exploits this potential advantage since it relies on idle users with good reception opportunities. OCRA is a two-phase protocol as described in Section II-A and is defined by the following operating conditions; see also Fig. 4.

- [S0] Let κ be a constant limiting the maximum achievable diversity. The period of the PN spreading code $c(t)$ is chosen to be $\mathcal{P} = \kappa T + 1$.
- [S1] At the beginning of each slot, if U_j 's queue is not empty, U_j enters phase-A with probability p and moves the first packet in the queue, $\mathbf{d}_{U_j} := \{d_{U_j}(l)\}_{l=0}^{L-1}$, to a single-packet buffer that we term phase-A buffer.
- [S2] **Phase-A:** When in phase-A, we say that $U_j \leftrightarrow A_j$ is an active-A user and transmits a packet spread according to (9) with PN-shift and power given by [c.f. [R2]]

$$\tau_{A_j} = 0, \quad P(A_j) = \rho P_0 \|A_j\|^\alpha / \xi, \quad (40)$$

with $\rho \in (0, 1)$. Notice that the PN shift is deterministically chosen and the transmission power is so that the packet is received at the AP with fractional power ρP_0 . A random integer, $\tau_{B_j} \sim \mathcal{U}[1, T]$, uniformly chosen over $[1, T]$ is included in the packet header to coordinate PN-shifts during phase-B. Let this transmitted packet be denoted as $\mathbf{x}_{A_j} := \{x_{A_j}(t)\}_{t=0}^{T-1}$.

- [S3] **Phase-A handshake:** Any idle user I_k that successfully decodes \mathbf{x}_{A_j} becomes a cooperator $I_k \leftrightarrow C_j^k$ and places \mathbf{d}_{U_j} in a single-packet buffer designated for cooperation purposes. This successful decoding is acknowledged to A_j who collects a total of K_j acknowledgments and feeds forward the number K_j to the cooperators. Similar

to e.g., [2], [8], [13] this handshake is assumed to be instantaneous and error free.

- [S4] User U_j enters phase-B in the slot immediately after entering phase-A.
- [S5] **Phase-B:** Let $\mathcal{C}_j = \{C_j^k\}_{k=0}^{K_j}$ be the set of cooperators as defined in Section II-A comprising $C_j^0 = B_j \leftrightarrow U_j$ and the K_j cooperators recruited in phase-A. Each of the C_j^k transmits the packet \mathbf{d}_{U_j} spread according to (9) using

$$\tau_{C_j^k} = \tau_{B_j} + \tau_k T, \quad P(C_j^k) = \frac{P_0}{K_j + 1} \|C_j^k\|^\alpha / \xi, \quad (41)$$

with τ_{B_j} the number received in phase-A's packet header, and the integer $\tau_k \sim \mathcal{U}[0, \kappa - 1]$. The power scaling is so that the total received power at the destination is P_0 . Let $\mathbf{x}_{C_j^k} := \{x_{C_j^k}(t)\}_{t=0}^{T-1}$ denote these transmitted packets. The number of cooperators K_j will be henceforth termed the "cooperation order" of B_j and the number κ_j of PN shifts chosen by at least one cooperator will be called the "diversity order" of B_j .

- [S6] **AP acknowledgement:** If the superposition of phase-B packets corresponding to B_j is successfully decoded, the AP acknowledges this event through a feedback channel. If an acknowledgement is not received, the packet \mathbf{d}_{B_j} is placed back in B_j 's queue. The cooperators discard this packet in any event.
- [S7] **Idle operation:** When not transmitting, $U_j \leftrightarrow I_j$ correlates the received signal with $\{c(t)\}_{t=0}^{T-1}$ to detect phase-A packets transmitted by other (nearby) users.

OCRA is a formal description of the two-phase protocol outlined in Section II based on the *opportunistic* exploitation of nearby users that happen to have a favorable signal reception of a given user. Phase-A is defined in rule [S2] by which U_j becomes the active-A user A_j and transmits \mathbf{x}_{A_j} with low power so as to reach nearby users while not interfering with the AP, this last situation requiring $\rho \ll 1$. Phase-B is defined by rule [S5] in which the packet is transmitted with κ_j -order diversity by $U_j \leftrightarrow B_j$ plus K_j cooperators corresponding to the K_j idle users that successfully decoded U_j 's transmission during phase-A. Note that the opportunistic nature of the protocol manifests in the random diversity order κ_j which depends on the number K_j of cooperators recruited and the random selection of shifts τ_k used by these cooperators. Let us also recall that user devices are half-duplex and can decode a single packet per slot when not transmitting.

Rules [S1], [S4] and [S6] govern the transition between idle and active-A/B states. The transition from idle to active-A happens with probability p as per [S1]; after entering phase-A, the user proceeds deterministically to phase-B in the first upcoming slot ([S4]), and in most cases back to idle in the second one ([S6]). A lost packet does not alter this transition but only determines whether the packet is put back in queue or not. Also, [S6] dictates that cooperators do not keep track of acknowledgements discarding B_j 's packet regardless of the transmission success. OCRA's complete transition diagram is slightly more involved due to the possibility of concurrent events. While most transitions are between idle and cooperator

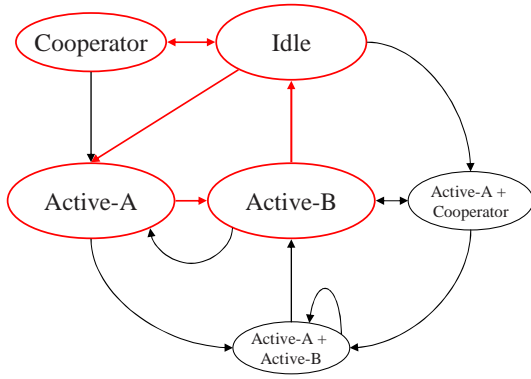

Fig. 5. Most of the transitions are between Idle and Cooperator and from Idle to Active-A to Active-B and back to Idle. Some less common transitions are also possible.

states and around the cycle idle to active-A to active-B to idle, other transitions and mixed states are also possible. Indeed, there is a chance for e.g., a user to be active-A and active-B in the same slot, or active-A and cooperators; also, instead of moving from active-B to idle we can move back to active-A if we independently choose to transmit a different packet. The complete transition diagram is shown in Fig. 5.

Rules [S0], [S3] and [S7] guarantee logical consistency of the protocol. According to [S0], the number of possible PN shifts is increased with respect to non-cooperative SSRA to enable the PN shift selection rule in phase-B [c.f. (41)]; [S3] disseminates the number of cooperators recruited to allow proper power scaling during phase-B as required by (41); and [S7] ensures that idle users are listening for phase-A packets.

A delicate issue in OCRA's description is the use of PN shifts, that is judiciously chosen to satisfy two requirements that we summarize in the following remark.

Remark 4 The PN shifts during phases A and B are selected in order to:

- [a] Facilitate decoding of phase-A's packet by idle users. Indeed, since phase-A packets use a fixed shift ($\tau_{A_j} = 0$), the idle users just need to correlate with a fixed sequence.
- [b] Let the AP combine different cooperative copies of the same packet. If $\tau_{B_{j_1}} \neq \tau_{B_{j_2}}$, then $\tau_{C_{j_1}^{k_1}} \neq \tau_{C_{j_2}^{k_2}} \forall k_1, k_2$, as can be seen from (41). Thus, if

$$\tau_{C_{j_1}^{k_1}} - \tau_{C_{j_2}^{k_2}} = \kappa_0 T \quad (42)$$

for some integer $\kappa_0 \in [0, \kappa - 1]$, then either the packets contains the same information, i.e., $j_1 = j_2$, or a hard collision occurred i.e. $\tau_{B_{j_1}} = \tau_{B_{j_2}}$.

Depending on their distances to the AP any user U_j experiences a propagation delay ω_{U_j} , so that if the latter is measured in chips, the PN shifts at the AP are perceived as $\tau_{U_j} + \omega_{U_j}$. While for SSRA propagation delays only add a random quantity ω_{U_j} to the already random τ_{U_j} , the remark in [b] is no longer valid for OCRA once we account for the propagation delay $\omega_{C_j^k}$. A simple solution used in e.g., the IS-95 standard [1], is to restrict the set of allowed shifts to a subset so that the difference in PN shifts is always larger

than the maximum propagation delay, i.e., $\tau_{U_{j_1}} - \tau_{U_{j_2}} > \max_{[1, J]} \{\omega_{U_j}\}$.

Remark 4 is important in practice. A third consequence of the selection of PN shifts having theoretical as well as practical significance is given in the following proposition.

Proposition 2 Given a slot with N_B active-B users, OCRA's hard collision probability (see Definition 1-[a]) for any reference user B_{j_1} is

$$P_{\text{HC}}(N_B) = 1 - \left(1 - \frac{1}{T}\right)^{N_B - 1}, \quad (43)$$

independently of the number of active-A users and cooperators' sets.

Proof: To evaluate this probability, note that $\tau_{C_{j_1}^{k_1}} = \tau_{C_{j_2}^{k_2}}$ can happen in two circumstances. The first is $j_2 = j_1$, in which case $\tau_{k_2} = \tau_{k_1}$ leads to $\tau_{C_{j_2}^{k_2}} = \tau_{C_{j_1}^{k_1}}$ according to (41). But in this case, both packets contain the same information and this is *not* a collision but just lost diversity² [c.f. Remark 4-[b]].

The second is $\tau_{B_{j_2}} = \tau_{B_{j_1}}$ for $j_2 \neq j_1$, in which case according to Remark 4-[b] the packets are combined as belonging to the same user. Thus, the hard collision event HC is equivalent to

$$\text{HC} = \bigcup_{j_2 \neq j_1} \{\tau_{B_{j_1}} = \tau_{B_{j_2}}\}. \quad (44)$$

Taking probabilities in (44) yields the expression

$$P_{\text{HC}}(N_B) = 1 - \prod_{\substack{j_2=1 \\ j_2 \neq j_1}}^{N_B} \Pr\{\tau_{B_{j_1}} \neq \tau_{B_{j_2}}\}. \quad (45)$$

But since the shifts $\tau_{B_{j_2}}$ are chosen uniformly and independently in $[1, T]$, we find that $\Pr\{\tau_{B_{j_1}} \neq \tau_{B_{j_2}}\} = (1 - 1/T)$ and (43) follows. ■

Comparing (22) with (43), we deduce that hard collisions in OCRA happen with exactly the same frequency as in non-cooperative SSRA. This is a design goal made possible by the increase in the PN sequence period \mathcal{P} as per [S0]. Certainly, this period cannot be made arbitrarily large since it must satisfy $\mathcal{P} \leq 2^S$, [6], effectively limiting the maximum achievable diversity order of OCRA to

$$\kappa = \frac{2^S - 1}{T}. \quad (46)$$

Notice though that since in general $2^S/T \gg 1$, the constraint in (46) is not severe in practice.

To wrap up this section, let us look at OCRA from the perspective of a terminal; see also Fig. 6. Each terminal maintains three separate transmission chains: the first one for the transmission of phase-A packets, a second one for the transmission of phase-B packets and a third one for the transmission of cooperative packets. The phase-A chain

²This requires noting that the sum of two normal random variables is also normally distributed so that the fading of the "combined" diversity path is also Rayleigh; see also (52).

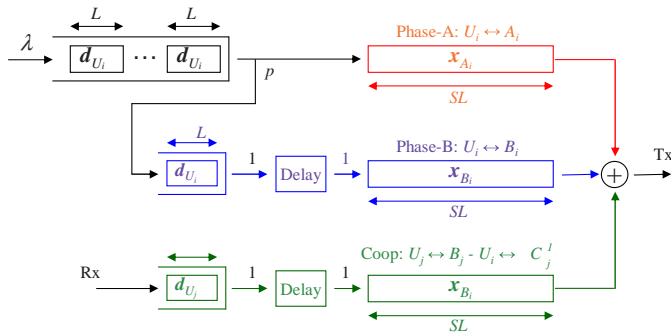

Fig. 6. Each terminal has three independent transmission chains that are combined using baseband digital signal processing.

is used with probability p ([S1]) and is fed with packets from the terminal's queue. If the user was in phase-A during the previous slot then it enters phase-B in the current one, activating the second transmission chain to transmit the packet stored in the phase-A buffer. The third chain is used when cooperating with other users and is activated whenever a packet is successfully decoded during the idle state.

The terminal can use more than one chain simultaneously, if it decides to enter phase-A in two consecutive slots, or, if it decodes another terminal's packet in the slot immediately before entering phase-A. Interestingly, not all the chains can be used simultaneously. As we can see from Fig. 5 mixed states include active-A plus cooperator and active-A plus active-B. Mixed states including active-B and cooperator never happen since this would require decoding a packet (to become cooperator) and being active-A (to become active B) in the previous slot. This is impossible for half-duplex terminals and consequently the active-B and cooperation chains are never used simultaneously.

Remark 5 This multi-transmission ability ensures that at any given time the random variables N_A and N_B are not only independent of each other but also that their distribution is not affected by the cooperation among users. Assuming a saturated system, we have that N_A and N_B follow binomial distributions with parameters J and p ; i.e.,

$$\Pr\{N_A = n\} = \Pr\{N_B = n\} = \binom{J}{n} p^n (1-p)^{J-n}. \quad (47)$$

Beyond a saturated system, this expression is also valid for the dominant system (see Section V). Finally, note that if U_j enters phase-A while being active-B or cooperator, it will fail in recruiting cooperators with high probability due to the self interference from high-power phase-B packets to low-power phase-A packets. This rather undesirable situation should be avoided in practice, but is allowed here to ensure independence between N_A and N_B .

A. Packet transmission and reception

The first problem we consider is signal transmission and reception in OCRA to abide by [S0]-[S7]. There are two signal reception instances in OCRA that we have to study. One is the detection of phase-A packets by nearby idle users and

the other one is the detection of the cooperative transmission of phase-B packets. If we call $\mathbf{d}_{A_j} = \{d_{A_j}(l)\}_{l=0}^{L-1}$ the unit-power information packet of the active-A user A_j , then the corresponding transmitted packet \mathbf{x}_{A_j} is constructed according to [S2] with entries

$$x_{A_j}(Sl + s) = \sqrt{P(A_j)} d_{A_j}(l)c(Sl + s), \quad (48)$$

$$l \in [0, L-1], s \in [0, S-1],$$

where we used $\tau_{A_j} = 0$ and $P(A_j)$ is given by (40). Likewise, if $\mathbf{d}_{B_j} = \{d_{B_j}(l)\}_{l=0}^{L-1}$ is the packet of the active-B user B_j , the packet transmitted by a given cooperator C_j^k is constructed according to [S5] and given by

$$x_{C_j^k}(Sl + s) = \sqrt{P(C_j^k)} d_{B_j}(l)c(Sl + s - \tau_{C_j^k}), \quad k \in [1, K_j] \quad (49)$$

with $\tau_{C_j^k}$ and $P(C_j^k)$ as in (41).

We first analyze the reception of a packet from a reference active-B user B_{j_0} . For that matter, let the received block at the AP be $\mathbf{z} = \{z(t)\}_{t=0}^{T-1}$ whose components are given by

$$z(Sl + s) = \sum_{j=1}^{N_B} d_{B_j}(l) \sum_{k=0}^{K_j} \sqrt{P(C_j^k)} h(C_j^k) c(Sl + s - \tau_{C_j^k}) + \sum_{j=1}^{N_A} \sqrt{P(A_j)} h(A_j) d_{A_j}(l) c(Sl + s) + n(Sl + s) \quad (50)$$

that is, the superposition of the cooperative N_B active-B transmissions, the N_A low power active-A transmissions and the receiver noise.

Let us focus on the detection of any one of the diversity paths of B_{j_0} 's communication say the one with PN-shift $\tau_{B_{j_0}, \kappa_0} := \tau_{B_{j_0}} + \kappa_0 T$. Since according to [S5] this shift is chosen by a random number of cooperators, we define the number of B_{j_0} 's cooperators that chose this shift as

$$N(B_{j_0}, \kappa_0) := \#\{C_{j_0}^k \in \mathcal{C}_{j_0} \text{ s.t. } \tau_k = \kappa_0\} := \#(C_{j_0}^{\kappa_0}) \quad (51)$$

where the cardinality operator $\#$ represents the number of elements in a set. Since the packets $\mathbf{x}_{C_{j_0}^k}$ of all cooperators in the set $C_{j_0}^{\kappa_0}$ share the PN shift $\tau_{B_{j_0}} - \kappa_0 T$, they are indistinguishable at the AP. Thus, all cooperators in $C_{j_0}^{\kappa_0}$ in (51) appear as a single path to the AP with composite Rayleigh fading coefficient

$$h(C_{j_0}^{\kappa_0}) := \sum_{k: \tau_k = \kappa_0} P(C_{j_0}^k) h(C_{j_0}^k). \quad (52)$$

Note that being a sum of complex Gaussian random variables, $h(C_{j_0}^{\kappa_0})$ is also complex Gaussian and the composite fading is also Rayleigh.

To recover the path $C_{j_0}^{\kappa_0}$, the AP compensates for the random phase by multiplying with the normalized composite channel conjugate $h_n^*(C_{j_0}^{\kappa_0}) := h^*(C_{j_0}^{\kappa_0})/|h(C_{j_0}^{\kappa_0})|$ and spreads with the proper PN shift. This yields the decision vector $\mathbf{r}_{C_{j_0}^{\kappa_0}} = \{r_{C_{j_0}^{\kappa_0}}(l)\}_{l=0}^{L-1}$ with entries

$$r_{C_{j_0}^{\kappa_0}}(l) = h_n^*(C_{j_0}^{\kappa_0}) \frac{1}{S} \sum_{s=0}^{S-1} z(Sl + s) c(Sl + s - \tau_{B_{j_0}} - \kappa_0 T). \quad (53)$$

If a hard collision does not occur, then $\tau_{B_{j_0}} \neq \tau_{B_j} \forall j \neq j_0$ and straightforward manipulations (see Appendix A.1) yield the per-path SINR as:

$$\begin{aligned} \text{SINR}(B_{j_0}, \kappa_0) &:= \frac{\mathbb{E}^2[r_{C_{j_0}^{\kappa_0}}(l)]}{\text{var}[r_{C_{j_0}^{\kappa_0}}(l)]} \\ &= S \frac{N(B_{j_0}, \kappa_0)/(K_{j_0} + 1)}{(N_B - 1) + \left(1 - \frac{N(B_{j_0}, \kappa_0)}{K_{j_0} + 1}\right) + \rho N_A + N_0/P_0}. \end{aligned} \quad (54)$$

Coherent combining of these κ_j paths leads to diversity order κ_j , with the PEP determined by the $\text{SINR}(B_{j_0}, \kappa_0)$ given by (54) for all the shifts $\kappa_0 \in [0, \kappa]$. Note that the denominator of $\text{SINR}(B_{j_0}, \kappa_0)$ in (54) contains a term $(N_B - 1)P_0$ accounting for the interference from other active-B users, a term $[1 - N(B_{j_0}, \kappa_0)/(K_{j_0} + 1)]P_0$ accounting for the self-interference of other paths of the same communication $B_{j_0} \rightarrow AP$ and a term $\rho N_A P_0$ for the active-A users's interference.

Remark 6 The analysis in this section should clarify the difference between cooperation order and diversity order as defined in [S5]. Note that κ_j is indeed the diversity order of the $B_j \rightarrow AP$ link, since the number of uncorrelated Rayleigh channels is precisely κ_j . In that regard, OCRA's diversity depends not only on the number of cooperation order K_j – as usual in most cooperative protocols – but also on the (random) selection of PN shifts by the user in \mathcal{C}_j .

The other reception instance is that of idle users decoding active-A transmissions. Consider the received vector at the idle user I_i denoted by $\mathbf{z}_{I_i} = \{z_{I_i}(t)\}_{t=0}^{T-1}$ with entries

$$\begin{aligned} z_{I_i}(Sl + s) &= \sum_{j=1}^{N_B} \sum_{k=0}^{K_j} \sqrt{P(C_j^k)} h(C_j^k, I_i) d_{B_j}(l) c[Sl + s - \tau_{C_j^k}] \\ &\quad + \sum_{j=1}^{N_A} \sqrt{P(A_j)} h(A_j, I_i) d_{A_j}(l) c[Sl + s] + n(Sl + s). \end{aligned} \quad (55)$$

In this case, we focus on decoding the reference active-A user $U_0 = A_{N_A}$. To construct the pertinent decision variable, we have to compensate for fading by multiplying with $h_n^*(U_0, I_i) := h^*(U_0, I_i)/|h(U_0, I_i)|$ and despreading with $c(t)$. Letting $\mathbf{r}_{I_i} = \{r_{I_i}(l)\}_{l=0}^{L-1}$ be the decision vector, we have

$$r_{I_i}(l) = h_n^*(U_0, I_i) \frac{1}{S} \sum_{s=0}^{S-1} z_{I_i}(Sl + s) c(Sl + s). \quad (56)$$

As we did for the AP, we can obtain the mean and variance of $r_{U_0}(l)$ (see Appendix A.2), and from there SINR_0^i , the SINR at idle user I_i for the signal of U_0 . Its inverse is given by

$$\begin{aligned} (\text{SINR}_0^i)^{-1} &:= \frac{\text{var}[r_{I_i}(l)]}{\mathbb{E}^2[r_{I_i}(l)]} = S^{-1} \sum_{j=1}^{N_B} \sum_{k=0}^{K_j} \frac{P(C_j^k \rightarrow I_i)}{P(U_0 \rightarrow I_i)} \\ &\quad + \sum_{j=1}^{N_A-1} \frac{P(A_j \rightarrow I_i)}{P(U_0 \rightarrow I_i)} + S^{-1} \frac{N_0}{P(U_0 \rightarrow I_i)} \end{aligned} \quad (57)$$

where the powers $P(U_j \rightarrow I_i)$ for the different users are obtained from the path loss model in (3). We remark that the interference from other active-A users is not reduced by the spreading gain, but (hopefully) by spatial separation.

The SINR in (57) determines the probability of I_i becoming a cooperator of U_0 , and as such, it is an important metric of OCRA that we will study in Section VI. But before that, we will introduce our main result pertaining to OCRA's throughput.

V. OCRA'S THROUGHPUT

Mimicking the steps we followed for the non-cooperative SSRA protocol in Section III, we can try to evaluate the aggregate throughput of OCRA. The hard collision probability coincides with the non-cooperative SSRA protocol and is given by Proposition 2. The soft collision probability, on the other hand, depends on both the number of active-A and active-B users and is given by [c.f. (23)]

$$P_{\text{SC}}(N_A, N_B) = P_e(N_A, N_B)[1 - P_{\text{HC}}(N_B)], \quad (58)$$

with $P_e(N_A, N_B)$ a function that maps the number of active-A and active-B users to the average PEP.

Using (58), we can compute the packet success probability conditioned on the number of interferers, namely $P_s(N_A, N_B) := 1 - P_{\text{HC}}(N_B) - P_{\text{SC}}(N_A, N_B)$. Using the latter and (43), (58) we find

$$P_s(N_A, N_B) = \left(1 - \frac{1}{T}\right)^{N_B} [1 - P_e(N_A, N_B)]. \quad (59)$$

Averaging (59) over the joint distribution of (N_A, N_B) and considering the average departure rate definition in (25), we find

$$\begin{aligned} \mu^{\text{OCRA}} &= p \sum_{n_B=0}^{J-1} \Pr\{N_B = n_B\} \left(1 - \frac{1}{T}\right)^{n_B} \\ &\quad \times \sum_{n_A=0}^J \Pr\{N_A = n_A\} [1 - P_e(n_A, n_B + 1)] \end{aligned} \quad (60)$$

were we used the independence of N_A and N_B discussed in Remark 5. For a saturated system, the probabilities $\Pr\{N_B = n_B\}$ and $\Pr\{N_A = n_A\}$ are binomially distributed as in (47). This motivates introduction of the dominant system obtained after replacing [S1] with:

[S1'] At the beginning of each slot, U_j enters phase-A with probability p and moves the first packet in its queue, $\mathbf{d}_{U_j} := \{d_{U_j}(l)\}_{l=0}^{L-1}$, to the phase-A buffer. If U_j 's queue is empty, it moves a dummy packet.

This modification renders the departure process stationary and we can claim, as we did in the proof of Proposition 1, that $\eta^{\text{OCRA}} = J\mu^{\text{OCRA}}$, with μ^{OCRA} given as in (60).

The difficulty in evaluating OCRA's throughput is cocooned in the function $P_e(N_A, N_B)$. This function depends on the diversity order κ_j , which depends on the number of co-operators K_j recruited during phase-A; while in theory we could compute K_j 's distribution and from there $P_e(N_A, N_B)$, this turns out to be analytically intractable and motivates the asymptotic approach of the next section.

A. OCRA's asymptotic throughput

Since OCRA's throughput $\eta^{OCRA}(J, N_0/P_0, S, \kappa, p, \rho)$ depends also on (κ, ρ) , it is convenient to differentiate the MST (as defined in (32)) depending on whether we optimize over ρ or not. If we consider ρ fixed, we define the ρ -conditional MST as:

$$\eta_{\max}^{OCRA}(J, N_0/P_0, S, \kappa|\rho) = \max_p \{ \eta^{OCRA}(J, N_0/P_0, S, p, \kappa, \rho) \} \quad (61)$$

with the maximum achieved at $p_{\max}(\rho) = \arg \max_p(\eta)$. If we jointly optimize over (p, ρ) , we define the MST as:

$$\eta_{\max}^{OCRA}(J, N_0/P_0, S, \kappa) = \max_{p, \rho} \{ \eta^{OCRA}(J, N_0/P_0, S, p, \kappa, \rho) \} \quad (62)$$

with the maximum achieved at $(p_{\max}, \rho_{\max}) = \arg \max_{(p, \rho)}(\eta)$. We adopt this second definition as the one equivalent to the non-cooperative SSRA MST defined in (32).

Having made this distinction, we can introduce the main results of this paper in the following two theorems.

Theorem 1 Consider the OCRA dominant system defined by rules [S0], [S1'] and [S2]-[S7] operating over a fading channel; and functions $\rho = \rho(J)$ and $K = K(J)$ such that $\lim_{J \rightarrow \infty} \rho = 0$ and $\lim_{J \rightarrow \infty} K = \infty$. Let $\mathcal{C}_j := \{C_j^k\}_{k=1}^{K_j}$ be the set of cooperators of the active-B user B_j for $j \in [1, N_B]$. If

- [h1] $\lim_{J \rightarrow \infty} (\rho^{2/\alpha} J/K) = \infty$, with α being the pathloss exponent in (3); and
- [h2] the transmission probability $p = p_{\max}(\rho)$ is chosen to achieve the MST given ρ ;

then

$$\lim_{J \rightarrow \infty} \Pr\{K_j \geq K/2, \forall j\} = 1. \quad (63)$$

Proof: See Section VI-B.

Theorem 1 establishes that every active-B user is receiving cooperation by at least $K/2$ users; moreover, as long as the convergence rates of $\rho(J)$ and $K(J)$ satisfy [h1] the cooperation order K_j becomes arbitrarily large while the active-A transmitted power becomes arbitrarily small. Consequently, the seemingly conflicting requirements of recruiting an infinite number of cooperators with a vanishingly small power are compatible as $J \rightarrow \infty$ implying that very large diversity orders are achievable by OCRA. A by-product of this comment leads to the following result.

Theorem 2 For any $\kappa \leq (2^S - 1)/T$, the asymptotic MST of OCRA operating over a Rayleigh fading channel η_{∞}^{OCRA} and the asymptotic throughput of non-cooperative random access over a κ -order, diversity channel η_{∞}^{κ} are equal; i.e.,

$$\lim_{J \rightarrow \infty} \eta_{\max}^{OCRA}(J, N_0/P_0, S, \kappa) := \eta_{\infty}^{OCRA}(N_0/P_0, S, \kappa) = \eta_{\infty}^{\kappa}(N_0/P_0, S). \quad (64)$$

Proof: For each value of J , choose (K, ρ, p) according to the conditions of Theorem 1. With its hypotheses satisfied, Theorem 1 states that for any active-B user we can map an arbitrarily large ($K_j > K/2$) number of cooperators to a finite

number of PN shifts κ . Accordingly, the number of elements in the set $C_j^{\kappa_0}$ in (51) satisfies

$$\lim_{J \rightarrow \infty} \frac{N(B_j, \kappa_0)}{K_j + 1} = 1/\kappa, \quad \forall \kappa_0 \in [1, \kappa], \quad (65)$$

due to the law of large numbers. Using (65) and $\lim_{J \rightarrow \infty} \rho = 0$, the per path SINR in (54) reduces to

$$\begin{aligned} \lim_{J \rightarrow \infty} \text{SINR}(B_j, \kappa_0) &= S \frac{1/\kappa}{N_B - 1 + (1 - 1/\kappa) + N_0/P_0} \\ &:= \bar{\gamma}(N_B, \kappa). \end{aligned} \quad (66)$$

Eq. (66) is, in part, a manifestation of the fact that as $J \rightarrow \infty$, the active-A users transmit with negligible power. But note that (66) is identical to the per-path SINR in a κ -order diversity channel [c.f. (36)], and because it is valid for every active-B user B_j and every shift κ_0 we infer that

$$\lim_{J \rightarrow \infty} P_e(N_A, N_B) = P_e^{\kappa}(\kappa \bar{\gamma}(N_B, \kappa)), \quad (67)$$

with $P_e(N_A, N_B)$ the function determining $P_{\text{SC}}(N_A, N_B)$ in (58) and $P_e^{\kappa}(\kappa \bar{\gamma}(N_B, \kappa)) = P_e^{\kappa}(\bar{\gamma}_{N_B})$ the corresponding member of the family of functions introduced in Definition 3.

Even though computing $P_e(N_A, N_B)$ is intractable, we can find its limit as $J \rightarrow \infty$; moreover, in the limit $P_e(N_A, N_B)$ is a function of N_B only, and we can compute the limit of the average departure rate in (60) as

$$\begin{aligned} \lim_{J \rightarrow \infty} \mu_{\max}^{OCRA} &= p_{\max} \sum_{n_B=0}^{J-1} \binom{J-1}{n_B} p_{\max}^{n_B} (1 - p_{\max})^{J-1-n_B} \\ &\quad \times \left(1 - \frac{1}{T}\right)^{n_B} [1 - P_e^{\kappa}(\kappa \bar{\gamma}(N_B, \kappa))] \end{aligned} \quad (68)$$

This is identical to the expression (28) of Proposition 1 when the channel is a κ -order diversity channel establishing that $\lim_{J \rightarrow \infty} J \mu_{\max}^{OCRA} = \eta_{\infty}^{\kappa}(N_0/P_0, S)$. To complete the proof, we invoke the same argument used in Proposition 1 about the dominant system to claim that

$$\begin{aligned} \eta_{\infty}^{OCRA}(N_0/P_0, S, \kappa) &:= \lim_{J \rightarrow \infty} \eta_{\max}^{OCRA}(J, N_0/P_0, S, \kappa) \\ &= \lim_{J \rightarrow \infty} J \mu_{\max}^{OCRA} \\ &= \eta_{\infty}^{\kappa}(N_0/P_0, S). \end{aligned} \quad (69)$$

The first equality follows from the definition of asymptotic throughput in (64), the second from the dominant system argument, and the last one by comparing (68) with (28). ■

Theorem 2 is the main result of this paper effectively stating that very high diversity orders are achievable by OCRA. Notice that the only constraint $\kappa \leq (2^S - 1)/T$, is not very restrictive in practice since we are interested in achieving diversity orders of no more than a few units and $2^S/T \gg 1$. Thus, it is fair to recall Remark 2 and assert that

$$\eta_{\infty}^{OCRA}(N_0/P_0, S, \kappa) = \eta_{\infty}^{\kappa}(N_0/P_0, S) \approx \eta_{\infty}^G(N_0/P_0, S), \quad (70)$$

with κ sufficiently large.

Surprisingly, user cooperation can improve the network throughput to the point of achieving wireline-like throughput

in a wireless RA environment. This is a subtle but significant difference relative to point-to-point user cooperation in fixed access networks, where the diversity advantage typically comes at the price of bandwidth expansion [9], [21].

VI. ON THE ASYMPTOTIC BEHAVIOR OF OCRA

In this section, we will show that Theorem 1 is a consequence of the spatial distribution of users. We will first consider a particular snapshot of an OCRA system with arbitrarily large N_I but fixed N_A and N_B , and study the distance ratios that determine the SINR (Lemma 2). From there, we prove that if [h1] in Theorem 1 is true, then every $I_0^{(k)}$ with $k \leq K$ correctly decodes U_0 's phase-A packet almost surely (Theorem 3). We will then establish that with high probability, the numbers of users N_A , N_B , and N_I in OCRA behave like the numbers of this particular snapshot (Lemma 3) from where Theorem 1 will follow.

A. A network snapshot

We consider in this subsection a fixed access network corresponding to a snapshot of the OCRA dominant system operating under [S0], [S1'] and [S2]-[S7]. In this fixed access network, N_A and N_B are fixed but the number of idle users $N_I \rightarrow \infty$. The problem we are concerned with is that of the reference active-A user U_0 trying to communicate with the idle users in \mathcal{I} . For each member of \mathcal{I} , the detection probability is determined by the SINR. If we let $\text{SINR}_0^{(k)}$ be such a metric at the k^{th} closest to U_0 idle user, we have

$$\begin{aligned} (\text{SINR}_0^{(k)})^{-1} := & S^{-1} \sum_{j=1}^{N_B} \sum_{k=0}^{K_j} \frac{P(C_j^k \rightarrow I_0^{(k)})}{P(U_0 \rightarrow I_0^{(k)})} \\ & + \sum_{j=1}^{N_A-1} \frac{P(A_j \rightarrow I_0^{(k)})}{P(U_0 \rightarrow I_0^{(k)})} + \frac{N_0}{P(U_0 \rightarrow I_0^{(k)})} \end{aligned} \quad (71)$$

which is obtained by setting $I_i = I_0^{(k)}$ in (57). The first sum in (71) corresponds to the N_B active-B users, the second sum to the N_A active-A users, and the third term accounts for the receiver noise. The upper limit $N_A - 1$ of the second sum follows from the convention $U_0 = A_{N_A}$.

To relate power terms in (71) with corresponding distances, let us consider first the (interfering) power received at I_0^k from B_j 's communication which involves the set of $K_j + 1$ cooperators $\mathcal{C}_j = \{C_j^k\}_{k=0}^{K_j}$:

$$P(B_j \rightarrow I_0^{(k)}) := \sum_{i=0}^{K_j} P(C_j^i \rightarrow I_0^{(k)}) = \frac{1}{K_j + 1} \sum_{i=0}^{K_j} \frac{P_0 \|C_j^i\|^\alpha}{\|C_j^i - I_0^{(k)}\|^\alpha} \quad (72)$$

where the second equality comes from the path loss model in (3) and the average power control enacted by [S5]. Less severe but not negligible interference is received from active-A users; for a specific A_j , we have

$$P(A_j \rightarrow I_0^{(k)}) = \frac{\rho P_0 \|A_j\|^\alpha}{\|A_j - I_0^{(k)}\|^\alpha}. \quad (73)$$

Remembering that U_0 's phase-A power is $\rho P_0 \|U_0\|^\alpha / \xi$ (so that it is received at the AP with power ρP_0), the signal power received at $I_0^{(k)}$ is $P(U_0 \rightarrow I_0^{(k)}) = \rho P_0 \|U_0\|^\alpha / \|U_0 - I_0^{(k)}\|^\alpha$, and we obtain [c.f. (71), (72), and (73)]

$$\begin{aligned} (\text{SINR}_0^{(k)})^{-1} = & \frac{1}{S\rho} \sum_{j=1}^{N_B} \sum_{i=0}^{K_j} \frac{1}{K_j + 1} \frac{\|C_j^i\|^\alpha \|U_0 - I_0^{(k)}\|^\alpha}{\|U_0\|^\alpha \|C_j^i - I_0^{(k)}\|^\alpha} \\ & + \sum_{j=1}^{N_A-1} \frac{\|A_j\|^\alpha \|U_0 - I_0^{(k)}\|^\alpha}{\|U_0\|^\alpha \|A_j - I_0^{(k)}\|^\alpha} + \frac{N_0}{\rho P_0} \frac{\|U_0 - I_0^{(k)}\|^\alpha}{\|U_0\|^\alpha}. \end{aligned} \quad (74)$$

The SINR expression in (74) determines the probability that a packet transmitted by U_0 with reduced power ($\rho \ll 1$) is received correctly at the k^{th} closest to U_0 idle user. We would prefer $\rho \rightarrow 0$ so that the interference added to the AP in (54) is negligible, and we want $k \rightarrow \infty$ so that the cooperation order grows large. As commented before, it will turn out that these seemingly conflicting requirements *are* compatible for N_I sufficiently large.

To establish this we need to establish two lemmas; the first one concerns the cumulative distribution function (CDF) of the distance between any two users.

Lemma 1 *If users are uniformly distributed in a disc of radius R , U_j denotes an arbitrary user (idle, active-A or active-B), and $F(r) := \Pr\{\|U_j - U_0\| < r | U_0\}$, then $F(r) = 0$ for $r < 0$, and*

$$\min \left\{ \frac{r^2}{4R^2}, 1 \right\} \leq F(r) \leq \min \left\{ \frac{r^2}{R^2}, 1 \right\}, \quad \text{for } r > 0. \quad (75)$$

Proof: See Appendix A.

Since users are uniformly distributed within a circle, their distance $\|U_j\|$ to the AP follows a quadratic CDF as asserted by (1). Lemma 1 establishes that their distance to any point, in this case to the reference user U_0 , has a CDF that is lower and upper bounded by a parabola.

This result is useful in establishing that some pertinent distance ratios are becoming arbitrarily large, as we quantify in the next lemma.

Lemma 2 *With N_I denoting the number of idle users, consider a function $\rho = \rho(N_I)$ that determines the phase-A fraction of power and a function $K = K(N_I)$ such that $\lim_{N_I \rightarrow \infty} \rho = 0$, $\lim_{N_I \rightarrow \infty} K = \infty$ and $\lim_{N_I \rightarrow \infty} (\rho^{2/\alpha} N_I / K) = \infty$. Then, for arbitrary $\mathcal{K} > 0$, the events*

$$e_1(N_I, \mathcal{K}) := \{\|U_0\| > (\mathcal{K}/\rho^{1/\alpha}) \|I_0^{(K)} - U_0\|\} \quad (76)$$

$$e_2(N_I, \mathcal{K}) := \{\|B_0^{(1)} - U_0\| > (\mathcal{K}/\rho^{1/\alpha}) \|I_0^{(K)} - U_0\|\} \quad (77)$$

$$e_3(N_I, \mathcal{K}) := \{\|A_0^{(1)} - U_0\| > \mathcal{K} \|I_0^{(K)} - U_0\|\} \quad (78)$$

have probability 1 as the number of idle users $N_I \rightarrow \infty$; i.e.,

$$\lim_{N_I \rightarrow \infty} \Pr\{e_l(N_I, \mathcal{K})\} = 1, \quad l = 1, 2, 3. \quad (79)$$

Proof: See Appendix B.

If we let \xrightarrow{p} denote convergence in probability, Lemma 2 implies that the distance ratios satisfy

$$\frac{\rho^{1/\alpha} \|U_0\|}{\|I_0^{(K)} - U_0\|}, \quad \frac{\rho^{1/\alpha} \|B_0^{(1)} - U_0\|}{\|I_0^{(K)} - U_0\|}, \quad \frac{\|A_0^{(1)} - U_0\|}{\|I_0^{(K)} - U_0\|} \xrightarrow{p} \infty, \quad (80)$$

for every ρ and K satisfying the conditions of Lemma 2.

Intuitively, U_0 's phase-A transmission will not be correctly decoded by $I_0^{(K)}$ when compared to the distance $\|I_0^{(K)} - U_0\|$, either because $I_0^{(K)}$ is close to an active-B user, or close to another active-A user, or, because U_0 is close to the AP. In the first two cases, the interference will be too high, and in the third case the signal will be too weak (being close to the AP, the power $P(U_0)$ is small because of [S2]). The importance of Lemma 2 is in establishing that all these events happen with vanishing probability and points out to the almost certainty of $I_0^{(K)}$ decoding U_0 's phase-A transmission successfully. This is formally asserted in the following theorem.

Theorem 3 Consider a set of N_A active-A users, $\mathcal{A} := \{A_j\}_{j=1}^{N_A}$; a set of N_I idle users, $\mathcal{I} := \{I_j\}_{j=1}^{N_I}$; and a set of N_B active-B users, $\mathcal{B} := \{B_j\}_{j=1}^{N_B}$, each receiving cooperation from a set of K_j idle users, $\mathcal{C}_j := \{C_j^k\}_{k=1}^{K_j}$. Let $U_0 = A_{N_A}$ be a reference user, $I_0^{(k)}$ be the k^{th} closest to U_0 idle user and $\mathcal{C}_0 := \{C_0^k\}_{k=0}^{K_0}$ be the set of idle users that decode U_0 's phase-A packet correctly (called U_0 's cooperators). If

[h1] the functions $\rho = \rho(N_I)$ and $K = K(N_I)$ satisfy $\lim_{N_I \rightarrow \infty} \rho = 0$ and $\lim_{N_I \rightarrow \infty} K = \infty$;

[h2] convergence rates are such that $\lim_{N_I \rightarrow \infty} (\rho^{2/\alpha} N_I / K) = \infty$; and

[h3] the transmitted powers are $P(C_j^k) = P_0 \|C_j^k\|^\alpha / [\xi(K_j + 1)]$, $P(A_j) = (\rho P_0 / \xi) \|A_j\|^\alpha$ and $P(U_0) = (\rho P_0 / \xi) \|U_0\|^\alpha$;

then

[a] as $N_I \rightarrow \infty$, the ratio of distances between B_j and its farthest cooperator $C_j^{(K_j)}$ and the distance between B_j and the AP converges to 0 in probability; i.e.,

$$\lim_{N_I \rightarrow \infty} \Pr \left\{ \frac{\|B_j - C_j^{(K_j)}\|}{\|B_j\|} < \epsilon \right\} = 1, \quad \forall \epsilon > 0 \quad (81)$$

[b] for every $k \leq K$, the event that $I_0^{(k)}$ becomes a cooperator is asymptotically almost sure; i.e.,

$$\lim_{N_I \rightarrow \infty} \Pr \{I_0^{(k)} \in \mathcal{C}_0\} = 1. \quad (82)$$

Proof: See Appendix D.

Theorem 3-[a] states that as we reduce the phase-A fraction of power, we do not recruit faraway idle users. In that sense, cooperators become clustered around the active-B user they are cooperating with nicely matching the intuition of cooperation with nearby users.

More important, Theorem 3-[b] establishes that the probability of each $I_0^{(k)}$, $k \leq K$, becoming a cooperator when phase-A transmission is reduced by a factor ρ converges to 1, as the number of idle users N_I grows large. Moreover, as long as $\lim_{N_I \rightarrow \infty} (\rho^{2/\alpha} N_I / K) = \infty$, the phase-A fraction of

power ρ can be made arbitrarily small and the number K of cooperators recruited arbitrarily large. The mathematical formalism here should not obscure the fact that this suggests the possibility of having an arbitrarily large number of terminals correctly decoding U_0 's active-A transmission with probability 1; and correspondingly enable arbitrarily large diversity order during phase-B when U_0 transmits with practically negligible power during phase-A.

Applying Theorem 3 to OCRA requires taking care of the randomness in the number of active-A and active-B users in a given slot, a problem that leads us to the next section.

B. Asymptotic Throughput

Theorem 3 establishes the potentially high cooperation order of the described fixed network access. The following lemma establishes that with high probability, an OCRA network is well described by the fixed network for which Theorem 3 has been proved.

Lemma 3 Let p_{\max} be the probability that achieves MST of the OCRA dominant system defined by rules [S0], [S1'] and [S2]-[S7]; assume that $0 < \eta_\infty := \lim_{J \rightarrow \infty} \eta_{\max} < \infty$ exists; and let $\bar{N} := \mathbb{E}(N_A) = \mathbb{E}(N_B) = p_{\max} J$ denote the average number of active-A (active-B) users. It then holds that

[a] the average number of users converges

$$\lim_{J \rightarrow \infty} \bar{N} = \bar{N}_\infty \quad (83)$$

to a finite constant $\bar{N}_\infty \in (0, \infty)$; and,

[b] the random variables N_A and N_B are asymptotically Poisson distributed:

$$\Pr\{N_B = n\} = \Pr\{N_A = n\} = \frac{\bar{N}^n}{n!} e^{-\bar{N}}. \quad (84)$$

Proof: If $\bar{N} \rightarrow \infty$, then the probability that all active-B users experience a hard collision goes to 1:

$$\lim_{J \rightarrow \infty} \bigcap_{j_0} \left\{ \bigcup_{j \neq j_0} \{\tau_{U_{j_0}} = \tau_{U_j}\} \right\} = 1, \quad (85)$$

since we have a finite number of PN shifts T and an infinite number of instantaneously active users; thus, $\lim_{J \rightarrow \infty} \bar{N} \neq \infty$. The fact that \bar{N} does not oscillate follows since $\bar{N}(J)$ is a non-decreasing function of J from where (83) follows. To prove claim [b], simply note that the conditions of Poisson's theorem are satisfied. ■

The importance of Lemma 3 is in establishing that as $J \rightarrow \infty$, the average number of active-A (active-B) users remains bounded; i.e., $\bar{N} \rightarrow \bar{N}_\infty < \infty$. This enables application of Theorem 3 to establish the asymptotically infinite order diversity of the OCRA network as claimed by Theorem 1 that we are now ready to prove.

Proof of Theorem 1: Eq. (63) can be written in terms of the complementary event

$$\Pr\{\cup_j (K_j < K/2)\} = 1 - \Pr\{K_j \geq K/2 \quad \forall j\}, \quad (86)$$

which we will prove convergent to zero. To this end, let us start by defining a network snapshot as the set

$\mathcal{S} := \{\mathcal{U}, \mathcal{A}, \mathcal{B}, \cup_j |_{U_j \in \mathcal{B}} \mathcal{C}_j\}$ composed of the realizations of user's positions and classes; and the index $k^* = \arg \max_{k \in [1, K]} \Pr\{I_0^{(k)} \notin \mathcal{C}_0 | \mathcal{S}\}$ corresponding to the idle user least likely to decode U_0 among the K closest ones when the snapshot \mathcal{S} is given.

We separate the failure in soliciting at least $K/2$ cooperators – the event $\{\cup_j (K_j < K/2)\}$ in (86) – in two cases: i) the realization \mathcal{S} is not favorable and we fail with high probability, e.g., when N_A, N_B are very large; and ii) \mathcal{S} is favorable and we succeed with high probability. For that matter, define the set of network realizations $\mathcal{S}_{\beta, N_{\max}} := \{\mathcal{S} | \Pr\{I_0^{(k^*)} \notin \mathcal{C}_0 | \mathcal{S}\} \leq \beta; N_A, N_B \leq N_{\max}\}$ for which the number of active-A and active-B users is less than N_{\max} , and the decoding failure probability is less than β , to write

$$\Pr\{\cup_j (K_j < K/2)\} = \Pr\{\cup_j (K_j < K/2) | \mathcal{S}_{\beta, N_{\max}}\} \Pr\{\mathcal{S}_{\beta, N_{\max}}\} + \Pr\{\cup_j (K_j < K/2) | \overline{\mathcal{S}_{\beta, N_{\max}}}\} \Pr\{\overline{\mathcal{S}_{\beta, N_{\max}}}\}. \quad (87)$$

Further recalling that probabilities are smaller than 1 we obtain

$$\Pr\{\cup_j (K_j < K/2)\} \leq \Pr\{\cup_j (K_j < K/2) | \mathcal{S}_{\beta, N_{\max}}\} + \Pr\{\overline{\mathcal{S}_{\beta, N_{\max}}}\}. \quad (88)$$

Applying the union bound to the event $\{\cup_j (K_j < K/2) | \mathcal{S}_{\beta, N_{\max}}\}$, we obtain

$$\Pr\{\cup_j (K_j < K/2)\} \leq N_{\max} \Pr\{K_j < K/2 | \mathcal{S}_{\beta, N_{\max}}\} + \Pr\{\overline{\mathcal{S}_{\beta, N_{\max}}}\} \quad (89)$$

since the number of active-B users is $N_B \leq N_{\max}$.

We start by bounding the first term in (89). To this end, we note that in order for $K_j < K/2$ we must have at least $K/2$ decoding failures among the K closest idle users during phase-A. Furthermore, the decoding probabilities at idle users are independent when conditioned on the network snapshot \mathcal{S} ; i.e., $\Pr\{I_0^{(k_1)}, I_0^{(k_2)} \in \mathcal{C}_0 | \mathcal{S}\} = \Pr\{I_0^{(k_1)} \in \mathcal{C}_0 | \mathcal{S}\} \Pr\{I_0^{(k_2)} \in \mathcal{C}_0 | \mathcal{S}\}$, and we can thus write

$$\Pr\{K_j < K/2 | \mathcal{S}\} < \sum_{k=K/2}^K \binom{K}{k} \left[\Pr\{I_0^{(k^*)} \notin \mathcal{C}_0 | \mathcal{S}\} \right]^k \times \left[\Pr\{I_0^{(k^*)} \in \mathcal{C}_0 | \mathcal{S}\} \right]^{K-k} \quad (90)$$

where we used the fact that by definition $\Pr\{I_0^{(k)} \notin \mathcal{C}_0 | \mathcal{S}\} \leq \Pr\{I_0^{(k^*)} \notin \mathcal{C}_0 | \mathcal{S}\}$ for all $k \in [1, K]$. The largest summand in (90) corresponds to $k = K/2$, which together with $\Pr\{I_0^{(K)} \in \mathcal{C}_0\}^{K-k} < 1$, yields

$$\Pr\{K_j < K/2 | \mathcal{S}\} < K/2 \binom{K}{K/2} \left[\Pr\{I_0^{(k^*)} \notin \mathcal{C}_0 | \mathcal{S}\} \right]^{K/2} \leq (K/2) 2^K \left[\Pr\{I_0^{(k^*)} \notin \mathcal{C}_0 | \mathcal{S}\} \right]^{K/2} \quad (91)$$

where we also used Stirlings' factorial approximation to obtain the last expression.

Now, use Bayes' rule and the bound in (91) to write

$$\Pr\{\cup_j (K_j < K/2) | \mathcal{S}_{\beta, N_{\max}}\} = \sum_{\mathcal{S} \in \mathcal{S}_{\beta, N_{\max}}} \Pr\{K_j < K/2 | \mathcal{S}\} \Pr\{\mathcal{S}\} \leq (K/2) 2^K \beta^{K/2}, \quad (92)$$

where in obtaining the inequality we used that for $\mathcal{S} \in \mathcal{S}_{\beta, N_{\max}}$ the decoding failure probability at $I_0^{(k^*)}$ satisfies $\Pr\{I_0^{(k^*)} \notin \mathcal{C}_0 | \mathcal{S}\} \leq \beta$ and that $\sum_{\mathcal{S} \in \mathcal{S}_{\beta, N_{\max}}} \Pr\{\mathcal{S}\} \leq 1$.

For $\beta = 1/8$ the latter bound reduces to $\Pr\{\cup_j (K_j < K/2) | \mathcal{S}_{\beta, N_{\max}}\} \leq (K/2) (1/2)^{K/2}$ which goes to zero as $K \rightarrow \infty$. Since $K \rightarrow \infty$ is implied when $J \rightarrow \infty$, we conclude from the latter that for any $\epsilon / (3N_{\max}) > 0$, $\exists J_0$ such that

$$\Pr\{K_j < K/2 | \mathcal{S}_{\beta, N_{\max}}\} < \epsilon / (3N_{\max}), \quad (93)$$

for every $J > J_0$.

To bound the second term in (89), we invoke Lemma 3-[a] and Theorem 3. First, note that we can write

$$\Pr\{\overline{\mathcal{S}_{\beta, N_{\max}}}\} = \Pr\{(N_B, N_A) > N_{\max}\} + \Pr\{\overline{\mathcal{S}_{\beta, N_{\max}}} | (N_B, N_A) < N_{\max}\}, \quad (94)$$

Lemma 3-[a] guarantees that we can choose N_{\max} sufficiently large so that

$$\Pr\{(N_B, N_A) > N_{\max}\} < \epsilon/3, \quad \forall J, \quad (95)$$

taking care of the the first term in (94). In the second term the numbers (N_B, N_A) of active-A and active-B users are given, and we can apply Theorem 3.

Note that since Theorem 3 is valid for any $k \leq K$, it must hold for $I_0^{(k^*)}$; and consequently, as $N_I := J - N_A - N_B > J - 2N_{\max} \rightarrow \infty$, we must have

$$\Pr\{I_0^{(k^*)} \notin \mathcal{C}_0 | (N_B, N_A) < N_{\max}\} \rightarrow 0, \quad (96)$$

when the failure probability is *not* conditioned on \mathcal{S} .

Suppose that $\Pr\{\overline{\mathcal{S}_{\beta, N_{\max}}} | (N_B, N_A) < N_{\max}\} > \epsilon/3 \forall J$ and argue by contradiction. Indeed, if this were true we would have $\Pr\{I_0^{(k^*)} \notin \mathcal{C}_0 | \mathcal{S}\} \geq \beta$ for a subset of network realizations $\{\overline{\mathcal{S}_{\beta, N_{\max}}} | (N_B, N_A) > N_{\max}\}$ with non-vanishing measure. But this is incompatible with (96) and consequently for any $\epsilon/3 > 0$, $\exists J > J_1$ such that

$$\Pr\{\overline{\mathcal{S}_{\beta, N_{\max}}} | (N_B, N_A) < N_{\max}\} < \epsilon/3. \quad (97)$$

Substituting (95) and (97) into (94), and the result of this operation along with (93) into (89), we finally obtain that

$$\Pr\{\cup_j (K_j < K/2)\} \leq \epsilon, \quad (98)$$

for arbitrary ϵ and all $J > \max(J_1, J_2)$. By definition, this implies the result in (63). ■

Besides establishing our major claim previewed in Section V-A, the asymptotic analysis of this section provides a series of byproduct remarks about OCRA:

Remark 7 *Average power constraint.* A consequence of the cooperators' clustering asserted by Theorem 3-[a] is that

cooperation is limited to nearby idle users; and accordingly, the total transmitted power by any active communication is

$$\sum_{k=0}^{K_j} P(C_j^k) \approx (K_j+1) \frac{P_0}{K_j+1} \|B_j\|^\alpha / \xi = P_0 \|B_j\|^\alpha / \xi. \quad (99)$$

Comparing (99) with rule [R2], we see that the average transmitted power in non-cooperative SSRA is equal to OCRA's phase-B power. The sole power increase is due to the phase-A power used to recruit cooperators, yielding the relation

$$P^{\text{OCRA}}(U_j) \approx (1 + \rho) P^{\text{SSRA}}(U_j) \quad (100)$$

between the power required by OCRA and non-cooperative SSRA. Since $\rho \rightarrow 0$, we deduce that OCRA enables high order diversity with a small increase in average transmitted power.

Remark 8 Maximum power constraint. A maximum power constraint $P(U_j) \leq P_{\max}$ determines the AP's coverage area, since power control dictates that $\|U_j\|^\alpha \leq (\xi P_{\max}/P_0) := R_c^\alpha$. But since power in OCRA is contributed by K_j cooperators, we have

$$R_c^{\text{OCRA}} = (K_j)^{1/\alpha} R_c^{\text{SSRA}}. \quad (101)$$

This increase in coverage stems from the fact that users in OCRA transmit less power during more time.

Remark 9 Network Area. The proofs rely on the asymptotic behavior of the distance ratios in Lemma 2. This behavior does not depend on the radius of the network, implying that we can make it arbitrarily large. Accordingly, our major claims in Theorems 1 and 2 are valid for a fixed area network with increasing user density as well as for a fixed user density network with increasing area.

Remark 10 OCRA with different physical layers. It is known that diversity in wireless networks requires a transmitter that enables, a channel that provides, and a receiver that collects diversity. While results in this paper have been derived for SSRA networks whose suitability in enabling and collecting diversity is well appreciated, the advantage of OCRA is that it *generates* multipath diversity in a channel that originally did not provide it. This result depends on the spatial distribution of users and can be readily established for RA networks with different physical layers. The difference in these other cases will be the way in which the diversity is enabled and collected; but retaining the essential diversity-providing structure of a low power phase-A followed by a high order diversity phase-B will lead to claims analogous to Theorems 1 and 2.

VII. UNSLOTTED OCRA

Packet de-spreading at the AP is performed through multiplication with the appropriately delayed version of the spreading sequence \mathbf{c} . Indeed, multiplication by $\mathbf{c}(t - \tau_{C_j^k})$ allows the AP to recover the k^{th} copy of B_j 's phase-B packet; and multiplication by $\mathbf{c}(t)$ allows idle users to detect A_j 's packet. Unfortunately, this requires knowledge of the delay $\tau_{C_j^k}$, and

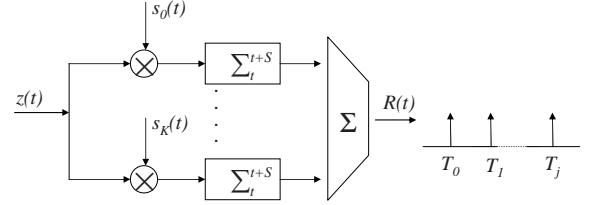

Fig. 7. In unslotted OCRA, the correlator shown can be used to detect the starting times of a packet. Simulations corroborate that slotted and unslotted OCRA exhibit similar throughputs.

the only way of accomplishing this in RA is by having the AP check all the (virtually infinite) possible shifts τ . This complexity can be reduced by altering the PN selection rule to let the nodes choose a random shift at the beginning of time, communicate this selection to the AP and then use the same shift for the life of the network. A more elegant solution to this problem is through an unslotted protocol as we outlined for non-cooperative SSRA networks in [19].

In this unslotted version, active-A and active-B users choose a random time to start transmitting, but they spread their packets with an *unshifted* version of the common PN sequence. This entails replacing rules [S1]-[S2] and [S4]-[S5] with the following.

- [U1] If U_j 's queue is not empty, U_j enters phase-A with probability p and moves the first packet in the queue, $\mathbf{d}_{U_j} := \{d_{U_j}(l)\}_{l=0}^{L-1}$, to the phase-A buffer.
- [U2] **Phase-A:** The transmission is as in [S2], but we include in the packet header the time T_{B_j} in which phase-B transmission is going to be attempted. The time T_{B_j} is chosen so that the transmission probability in each time unit is p .
- [U4] U_j enters phase-B at time T_{B_j} .
- [U5] **Phase-B:** Transmission is as in [S5] but when spreading \mathbf{d}_{U_j} the cooperator C_j^k uses the shift

$$\tau_{C_j^k} = \tau_k T, \quad (102)$$

with $\tau_0 = 0$ and $\tau_k \sim \mathcal{U}[0, \kappa - 1]$.

When expressed with respect to a common time reference, the equivalent of (48) for this unslotted system becomes

$$x_{A_j}(Sl+s) = \sqrt{P(A_j)} d_{A_j}(l) c(Sl+s-T_{A_j}) \Pi(Sl+s-T_{A_j}) \quad (103)$$

where $\Pi(t)$ is a unit-amplitude square pulse with nonzero support over $t \in (0, NL)$. Relying on (103), we can repeat the steps in Appendix A.2 to deduce that this spreading rule achieves statistical user separation at the idle users. Similarly, for the cooperative phase-B transmissions the counterpart of (49) is

$$x_{C_j^k}(Sl+s) = \sqrt{P(C_j^k)} d_{B_j}(l) \times c(Sl+s-T_{B_j}-\tau_k T) \Pi(Sl+s-T_{B_j}) \quad (104)$$

with $k \in [0, K_j]$. Again, by following the steps in Appendix A.2 we can prove that this achieves statistical user separation at the AP.

The difference is that the first symbol in every packet is always spread by the same set of chips. Upon defining the (short) periodic sequences

$$c_k(t) = c(t - kSL \bmod S), \quad k \in [0, \kappa - 1]; \quad (105)$$

which amounts to periodically repeating the first S chips that spread the first symbol of any packet $\mathbf{x}_{C_j^k}$ or \mathbf{x}_{A_j} ; the output of a continuous correlator matched to $s_k(t)$ can be used to detect the beginning of a packet; see also Fig 7. Indeed, the sum of the outputs of these correlators is

$$R(t) = \sum_{k=0}^{\kappa} \sum_{t'=t}^{t+S} c_k(t')z(t') = \sum_{k=0}^{\kappa} \sum_{t'=t}^{t+S} c(-kT)z(t'), \quad (106)$$

since we have that $c_k(t) = c(-kSL)$ in an interval of length S . But $E(R(t)) = 0$, except when a packet started at time t , in which case $E(R(t)) = \pm SP_0$, the sign being the value of the transmitted bit. Accordingly, the event $|R(t)| > SP_0/2$ can be used by the AP to identify the starting time of B_j 's packet at $T_{B_j} = t$. A similar correlator with $\kappa = 0$ in (106) can be used by the idle users to identify the times T_{A_j} .

Thus, an unslotted version of OCRA reduces the challenging task of identifying the random shifts τ_{B_j} to the easier problem of identifying the random times T_{B_j} . Interestingly, the number of correlations computed does not change; what changes is that instead of taking κT correlations at the beginning of a slot, we take κ correlations during T times. The difference is, of course, that Theorems 1 and 2 (and all other results for that matter) apply to the unslotted version. In the next section, we simulate unslotted OCRA as defined by rules [S0], [U1]-[U2], [S3], [U4]-[U5] and [S6]-[S7] to unveil that as is usual in SSRA networks (see e.g., [8]) the throughput of this practically feasible unslotted version is accurately predicted by the theoretical results derived for the slotted version.

VIII. SIMULATIONS

We have established in this paper that slotted OCRA operating over a Rayleigh fading channel can asymptotically achieve the throughput of an equivalent non-cooperative SSRA operating over an AWGN channel, promising an order of magnitude increase in throughput. In this section, we explore three questions of significant practical importance that our theoretical results left only partially answered. These questions are: i) does slotted OCRA results carry over to unslotted OCRA? ii) how large the number of users should be to achieve a significant throughput increase? and iii) how do we select ρ and κ ? To address i), we performed simulations for slotted and unslotted OCRA obtaining almost identical results in all the metrics studied; to avoid presenting virtually identical figures, we report only the figures pertaining to unslotted OCRA stressing the fact that they basically coincide with the curves for slotted OCRA. The answers to ii) and iii) are provided in the remainder of this section.

Consider first question ii) and refer to Fig. 8 where we depict unslotted OCRA's MST, η_{\max}^{OCRA} , as a function of the

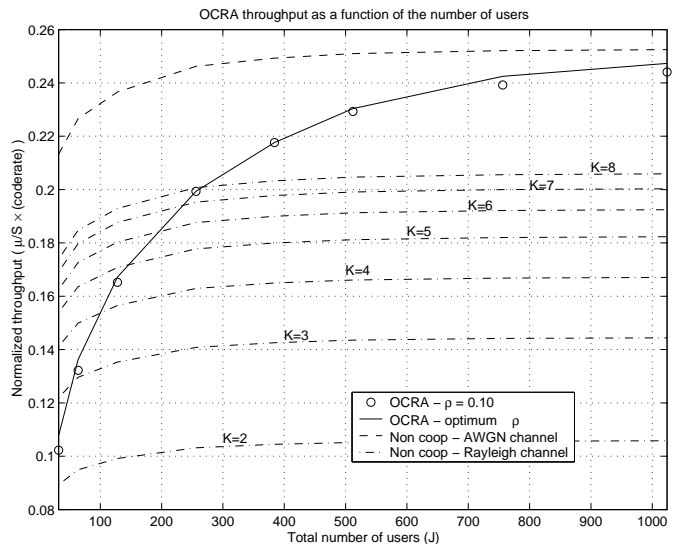

Fig. 8. OCRA captures a significant part of the diversity advantage in mid-size networks; the MST for $J = 128$ is $2/3$ the MST of SSRA over an AWGN channel ($\kappa = 10$, $S = 32$, $L = 1024$, 215/255 BCH code capable of correcting $t = 5$ errors).

number of users J in a network with spreading gain $S = 32$, packet length $L = 1024$, and a 215/255 BCH code capable of correcting $t = 5$ errors used for FEC. A quick inspection of Fig. 8 reveals that convergence to AWGN throughput is rather slow since for J as large as 512 there is still a noticeable gap. Notwithstanding, the throughput increase is rather fast; for $J = 64$ there is a threefold throughput increase ($\eta_{\max} = 0.04$ if the channel is Rayleigh), and for $J = 128$ OCRA's MST is $2/3$ of the MST achieved by non-cooperative SSRA over an AWGN channel. Thus, while collecting the full diversity advantage requires an inordinately large number of users, OCRA can collect a significant percentage of it in moderate size networks, with a ratio $J/S \approx 4$. This behavior can be explained through the background curves that show the MST of non-cooperative systems with increasing diversity order. These curves illustrate the well understood behavior that the throughput increase when the diversity order goes from 2 to 3 is much larger than the increase when the diversity order goes from 7 to 8, [26]. Moreover, a large part of the potential increase is collected with order 5 diversity. As a diversity enabler, OCRA quickly achieves 5-order diversity when $J \approx 128$; but additional improvements in the diversity order translate to increasingly small throughput increments.

Similar conclusions can be drawn from the simulation with $J = 128$ users depicted in Figs. 9 and 10. For this case study, we show throughput and average diversity as a function of the transmission probability p . For the range of probabilities close to the MST, OCRA's throughput remains between the curves for 4 and 5-order diversity, consistent with the fact that the average degree of cooperation that users receive is between 4 and 5.

Turning our attention to question iii), let us recall the distinction between ρ -conditional MST in (61) and MST in (62). Interestingly, optimizing over (ρ, p) provides a small throughput increase with respect to optimizing over p only, as

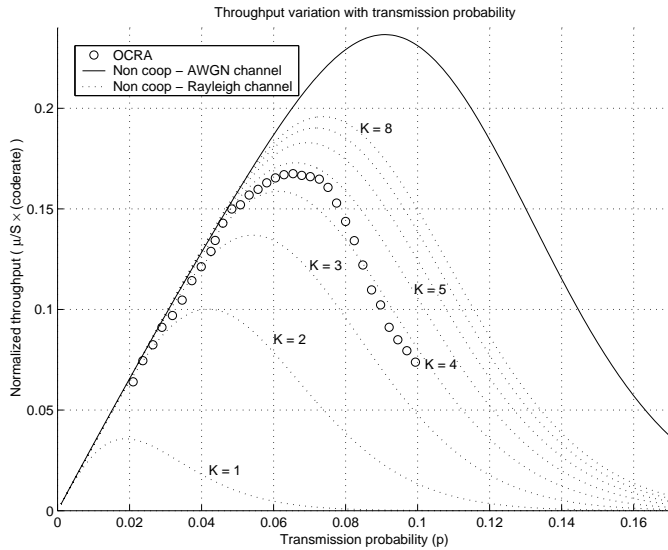

Fig. 9. OCRA throughput with variable packet transmission probability p . In the range shown, OCRA's throughput remains between the throughput of non-cooperative SSRA over Rayleigh channels with diversity of order 4 and 5 ($\rho = 0.01$, $\kappa = 10$, $J = 128$, $S = 32$, $L = 1024$, 215/255 BCH code capable of correcting $t = 5$ errors).

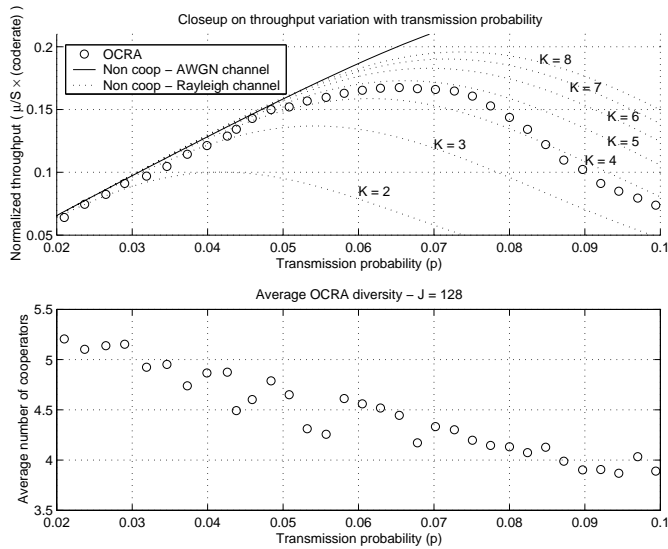

Fig. 10. A closer look to Fig 9. OCRA's throughput is consistent with the fact that the average number of cooperators is between 4 and 5 ($\rho = 0.01$, $\kappa = 10$, $J = 128$, $S = 32$, $L = 1024$, 215/255 BCH code capable of correcting $t = 5$ errors).

can be seen in Fig. 8. In this plot, the solid line depicts OCRA's MST and the circles depict the ρ -conditional MST, when we set $\rho = 0.01$. In the vast operational range shown, there is no noticeable difference between these two approaches. This has the important practical implication that we do not need to optimize ρ , removing a significant part of the added complexity that OCRA incurs relative to non-cooperative SSRA.

Finally, it is interesting to check our intuition about OCRA by looking at the network snapshots depicted in Figs. 11 and 12. OCRA effectively exploits wasted resources in non-cooperative RA, namely idle users' transmitters, as can be seen in Fig 11. In a conventional SSRA, only a small number of

active-B users would be transmitting; whereas in OCRA, the cooperators are a significant percentage of the total number of users. This does not change as the number of users increases since when we go from $J = 128$, Fig. 11 (left) to $J = 256$, Fig. 11 (right), the number of cooperators per user increases so as to exploit the otherwise wasted cooperators' transmitters. It is also interesting to verify that as predicted by Theorem 3 the cooperators become clustered around the active-B user they are cooperating with.

The perspective of an active-A user can be summarized in the interference map depicted in Fig. 12. Each point in this map represents the total power received from all active-B users and their cooperators, and effectively represents the amount of noise in the active-A to idle users links. Thus, idle users in purple (dark gray) spots have low SINR and are not likely to be recruited as cooperators and idle users in green-yellow (intermediate gray) spots have large SINR and are likely to be recruited as cooperators. As the network size increases, the interference map is essentially unchanged by Lemma 3, but the signal power in the active-A to idle users links increases. This translates to an increase of the green-yellow (intermediate gray) area when the number of users increases from $J = 128$, Fig. 12 (left) to $J = 256$, Fig. 12 (right). Since users are uniformly distributed, this also translates to an increased number of idle users with good reception opportunities for active-A packets.

The simulations presented provide a reasonable answer to questions i) – iii) at the beginning of the section corroborating that: i) unslotted OCRA behaves as slotted OCRA; ii) the asymptotic behavior applies even to moderate-size networks having $J/S \approx 4$; and iii) $\rho \approx 0.1$ is a reasonable rule of thumb, and $\kappa \approx 10$ enables 4 to 6 diversity paths.

IX. CONCLUSIONS

With the goal of migrating user cooperation benefits to random access channels, we introduced the OCRA protocol which we showed capable of effecting a significant throughput increase with respect to equivalent non-cooperative random access protocols. Testament to this significant advantage is the fact that as the number of users in the network increases, OCRA's throughput over Rayleigh fading links approaches that of the corresponding SSRA protocol over AWGN links, without an energy penalty. Accordingly, *OCRA has the capacity of rendering a wireless RA channel equivalent to a wireline one from the throughput perspective*. This is a striking difference with point to point cooperation, where the diversity comes at the expense of bandwidth expansion. The price paid is a modest increase in the complexity (and therefore cost) of the baseband circuitry.

Simulations demonstrated that our asymptotic results can be perceived in realistic-sized networks, since the asymptotic results manifest for moderate values of the total number of users.

The OCRA protocol relies on a two-phase transmission in which users first transmit with reduced power trying to reach nearby users, whose cooperation is thereby solicited for the subsequent slot. In this second slot, the (random) number of

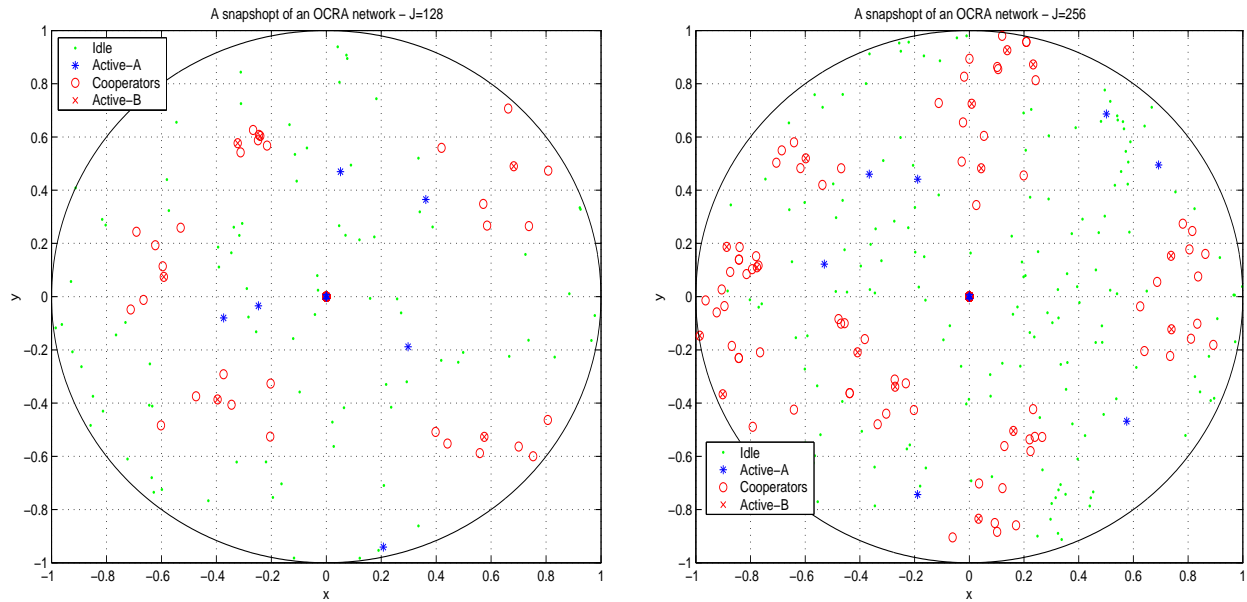

Fig. 11. Snapshots of OCRA networks. OCRA effectively exploits the otherwise wasted cooperators' transmitters to provide user cooperation diversity ($p = p_{\max}(\rho)$ $\rho = 0.01$, $\kappa = 10$, $J = 128$ in left, $J = 256$ in right, $S = 32$, $L = 1024$, 215/255 BCH code capable of correcting $t = 5$ errors).

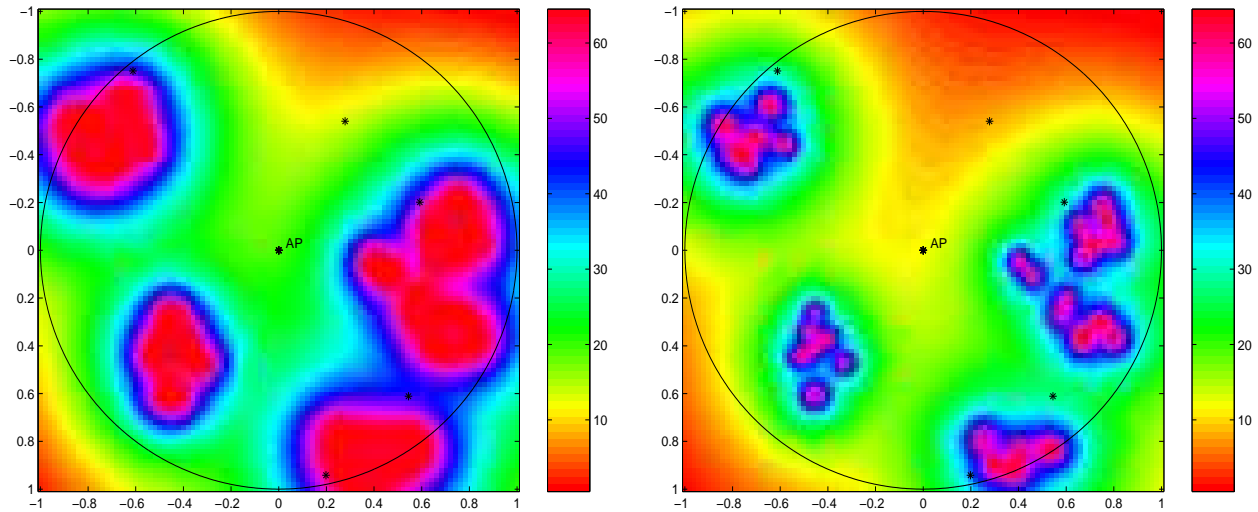

Fig. 12. Interference maps. The color (gray level) scale represents the total interference in dB received from active-B users at any point in space. As the number of users increases, the interference map remains essentially the same but the signal power received at idle users from active-A users increases. This translates in an increased number of idle users with good reception opportunities for active-A packets ($p = p_{\max}(\rho)$ $\rho = 0.01$, $\kappa = 10$, $J = 128$ in left, $J = 256$ in right, $S = 32$, $L = 1024$, 215/255 BCH code capable of correcting $t = 5$ errors).

cooperators recruited transmit cooperatively to the destination. While a specific (spread spectrum) physical layer support was assumed, the same approach and results can be applied to other physical layers with the consequence of an intrinsic suitability of user cooperation as *the* form of diversity for random access networks.

X. APPENDICES

A. Other users' interference in OCRA 1

1) *Signal reception at the AP:* Substituting the explicit value of $z(Sl + s)$ in (50) into (53) and using the expression for the composite fading coefficient in (52) we can write the

decision statistic $r_{C_{j_0}^{\kappa_0}}(l)$ as

$$\begin{aligned}
 r_{C_{j_0}^{\kappa_0}}(l) &= h(C_{j_0}^{\kappa_0})h_n^*(C_{j_0}^{\kappa_0})d_{B_{j_0}}(l) + \sum_{\substack{j=1 \\ j \neq j_0}}^{N_B} \sum_{k=0}^{K_j} \mathbb{I}(l; C_{j_0}^{\kappa_0} \rightarrow AP; C_j^k) \\
 &+ \sum_{\substack{k=0 \\ \tau_k \neq \kappa_0}}^{K_{j_0}} \mathbb{I}(l; C_{j_0}^{\kappa_0} \rightarrow AP; C_{j_0}^k) + \sum_{j=1}^{N_A} \mathbb{I}(l; C_{j_0}^{\kappa_0} \rightarrow AP; A_j) + \tilde{n}(l)
 \end{aligned} \tag{107}$$

where we used the notation (introduced after (11)) $\mathbb{I}(l; C_{j_0}^{\kappa_0} \rightarrow AP; U)$ to represent the interference of user U to the aggregate

link $C_{j_0}^{\kappa_0} \rightarrow AP$ for the transmission of the l^{th} bit. The first group of interference terms corresponds to the active-B users $B_j \neq B_{j_0}$, the second group to the cooperators of B_{j_0} that chose a different shift $\tau_k \neq \kappa_0$, and the third group to the active-A users. These interference terms are given by

$$\begin{aligned} \mathbb{I}(l; C_{j_0}^{\kappa_0} \rightarrow AP; U) &= \sqrt{P(U)} h(U) h_n^*(C_{j_0}^{\kappa_0}) d_U(l) \\ &\times \frac{1}{S} \sum_{s=0}^{S-1} c(Sl+s-\tau_U) c(Sl+s-\tau_{B_{j_0}} - \kappa_0 T) \end{aligned} \quad (108)$$

with U denoting alternatively C_j^k $j \neq j_0$, $C_{j_0}^k$ $\tau_k \neq \kappa_0$, and A_j .

Using the low autocorrelation property of long PN sequences, we obtain that if $\tau_{C_{j_0}^{\kappa_0}} \neq \tau_U$ – for what it suffices to have $\tau_{B_{j_0}} \neq \tau_{B_j}$, for $j \in [1, N_B]$, $j \neq j_0$ – then

$$\mathbb{E}[\mathbb{I}(l; C_{j_0}^{\kappa_0} \rightarrow AP; U)] = 0 \quad (109)$$

$$\text{var}[\mathbb{I}(l; C_{j_0}^{\kappa_0} \rightarrow AP; U)] = (1/S)P(U)\mathbb{E}[|h(U)|^2] \quad (110)$$

$$\mathbb{E}[\mathbb{I}(l; C_{j_0}^{\kappa_0} \rightarrow AP; U_1)\mathbb{I}^*(l; C_{j_0}^{\kappa_0} \rightarrow AP; U_2)] = 0. \quad (111)$$

Since when $\tau_{C_{j_0}^{\kappa_0}} \neq \tau_U$ all the random variables in (108) are independent, we have that: i) eq. (109) follows immediately since any of the involved random variables has zero mean; ii) when computing the variance in (110) we have that $\mathbb{E}[h(U)h^*(U)] = \mathbb{E}[|h(U)|^2]$, $\mathbb{E}[h_n^*(C_{j_0}^{\kappa_0})h_n^*(C_{j_0}^{\kappa_0})] = 1$, $\mathbb{E}[d_{U_j}(l)] = 1$, and among the S^2 cross-products involving the code c only S of them are not null; and iii) to establish (111) it suffices to note that $h(U_1)$ and $h(U_2)$ are independent and zero-mean.

Using property (109) we can see that none of the interference terms in (107) contributes to the mean of $r_{C_{j_0}^{\kappa_0}}(l)$ and consequently

$$\mathbb{E}[r_{C_{j_0}^{\kappa_0}}(l)] = \mathbb{E}[|h(C_{j_0}^{\kappa_0})|] = \sqrt{\frac{P_0 N(B_{j_0}, \kappa_0)}{K_{j_0} + 1}} d_{B_{j_0}}(l), \quad (112)$$

since the composite channel $h(C_{j_0}^{\kappa_0})$ contains $N(B_{j_0}, \kappa_0)$ terms, each with power $P_0/(K_{j_0} + 1)$. Likewise, (111) allows us to separate the variance in independent terms

$$\begin{aligned} \text{var}[r_{C_{j_0}^{\kappa_0}}(l)] &= \mathbb{E}[\tilde{n}^2(l)] + \sum_{\substack{j=1 \\ j \neq i}}^{N_B} \sum_{k=0}^{K_j} \mathbb{E}[|\mathbb{I}(l; C_{j_0}^{\kappa_0} \rightarrow AP; C_j^k)|^2] \\ &+ \sum_{\substack{k=0 \\ k \neq \kappa_0}}^{K_j} \mathbb{E}[|\mathbb{I}(l; C_{j_0}^{\kappa_0} \rightarrow AP; C_{j_0}^k)|^2] + \sum_{j=1}^{N_A} \mathbb{E}[|\mathbb{I}(l; C_{j_0}^{\kappa_0} \rightarrow AP; A_j)|^2] \end{aligned} \quad (113)$$

Evaluating the expected values in (113) we obtain

$$\begin{aligned} \text{var}[r_{C_{j_0}^{\kappa_0}}(l)] &= N_0 + (N_B - 1) \frac{P_0}{S} \\ &+ [K_{j_0} + 1 - N(B_{j_0}, \kappa_0)] \frac{P_0}{S(K_{j_0} + 1)} + N_A \frac{\rho P_0}{S} \end{aligned} \quad (114)$$

where we used: i) property (110), ii) the power control rules $P(A_j)\mathbb{E}[|h(AP, A_j)|^2] = \rho P_0$ in (40) and

$P(C_j^k)\mathbb{E}[|h(AP, C_j^k)|^2] = P_0/(K_j + 1)$ in (41), and iii) that the number of summands in the second sum is $[K_{j_0} + 1 - N(B_{j_0}, \kappa_0)]$,

From (112) and (114), the SINR in (54) follows from its definition.

2) *Signal reception at idle users:* Using once again the notation $\mathbb{I}(l; U_0 \rightarrow I_i; U)$ to denote the interference of U to the communication of the l^{th} bit of the packet d_{U_0} from U_0 to I_i , the entries of the decision vector in (56) can be written as

$$\begin{aligned} r_{U_0}(l) &= \sqrt{P(U_0)} h(U_0, I_i) d_{U_0}(l) + \sum_{j=1}^{N_B} \sum_{k=0}^{K_j} \mathbb{I}(l; U_0 \rightarrow I_i; C_j^k) \\ &+ \sum_{j=1}^{N_A-1} \mathbb{I}(l; U_0 \rightarrow I_i; A_j) + \tilde{n}(l) \end{aligned} \quad (115)$$

where $\mathbb{E}[P(U_0)|h(U_0, I_i)|^2] = P(U_0 \rightarrow I_i)$ is the power received from U_0 at I_i and is given by the pathloss model (3). The interference terms are given by [c.f. (55)]

$$\begin{aligned} \mathbb{I}(l; U_0 \rightarrow I_i; U) &= \sqrt{P(U)} h(U, I_i) h_n^*(U_0, I_i) d_U(l) \\ &\times \frac{1}{S} \sum_{s=0}^{S-1} c(Sl+s-\tau_U) c(Sl+s) \end{aligned} \quad (116)$$

where, as before, $\mathbb{E}[P(U)|h(U, I_i)|^2] = P(U_j \rightarrow I_i)$ can be obtained from (3).

The important observation is that for active-B transmissions, including active-B terminals and their cooperators, the autocorrelation property of PN codes yields that $\mathbb{E}[\mathbb{I}(l; U_0 \rightarrow I_i; U)] = 0$, $\text{var}[\mathbb{I}(l; U_0 \rightarrow I_i; U)] = P(U \rightarrow I_i)/S$ and $\mathbb{E}[\mathbb{I}(l; U_0 \rightarrow I_i; U_1)\mathbb{I}^*(l; U_0 \rightarrow I_i; U_2)] = 0$ deterministically, since the 0^{th} PN shift is reserved for active-A users.

For active-A users however, the PN shifts are all equal and we have

$$\mathbb{E}[\mathbb{I}(l; U_0 \rightarrow I_i; A_j)] = 0, \quad (117)$$

$$\text{var}[\mathbb{I}(l; U_0 \rightarrow I_i; A_j)] = P(A_j \rightarrow I_i), \quad (118)$$

$$\mathbb{E}[\mathbb{I}(l; U_0 \rightarrow I_i; A_{j_1})\mathbb{I}^*(l; U_0 \rightarrow I_i; A_{j_2})] = 0, \quad (119)$$

where (117) and (119) follow from the independence between different user's fading coefficients and the fact that in (118) the interfering power is not reduced by the spreading gain, as usual.

Using these properties, we can compute the expected value and the variance of $r_{U_0}(l)$; and from there, the SINR $_0^i$ in (57).

B. Proof of Lemma 1

In order to have $\|U_j - U_0\| < r$, user U_j must lie in the region

$$U_j \in \mathcal{O}(0, R) \cap \mathcal{O}(U_0, r) := \mathcal{R}, \quad (120)$$

where $\mathcal{O}(o, r)$ denotes a circle with center o and radius r . The probability of U_j being in \mathcal{R} is simply

$$F(r) = \frac{\text{area}(\mathcal{R})}{\pi R^2}. \quad (121)$$

The right inequality in (75) follows from (121) after noting that

$$\text{area}(\mathcal{R}) < \text{area}[\mathcal{O}(U_0, r)] = \pi r^2. \quad (122)$$

The left inequality in (75) requires considering the case in which the intersection of $\mathcal{O}(U_0, r)$ with $\mathcal{O}(0, R)$ subtracts most of the area from $\mathcal{O}(U_0, r)$. This happens when U_0 is at the border of $\mathcal{O}(U_0, r)$ and $r = 2R$. In this case,

$$\text{area}(\mathcal{R}) = \pi R^2 = \frac{\pi r^2}{4}. \quad (123)$$

QED. \blacksquare

C. Proof of Lemma 2

The proofs for all events are similar. We prove the lemma for $e_2(N_I, \mathcal{K})$ that is the most representative, and sketch the proofs for the remaining events.

Remark 11 In the subsequent proofs we exploit the fact that active-A and active-B users' positions are independent. Indeed, users that enter phase-A in a given slot enter phase-B in the subsequent one regardless of whether they succeeded in recruiting cooperators or not. Furthermore, users enter phase-A regardless of their knowledge regarding the activity of neighboring nodes. This is rather "foolish" since we are allowing transmissions with small success probability, but nonetheless allowed to maintain independence between active-A and active-B users' positions. See also Remark 5.

1) *Proof for event $e_2(N_I, \mathcal{K})$:* To simplify notation define $\mathcal{K}' := \mathcal{K}/\rho^{1/\alpha}$. Recall that $F(r)$ is the distribution of $\|B_j - U_0\|$ given U_0 , and note that since the positions of the N_B active-B users are assumed independent, we have

$$\begin{aligned} \Pr\{\|B_0^{(1)} - U_0\| > r \mid U_0\} &= \Pr\left\{\bigcap_{j=1}^{N_B} (\|B_j - U_0\| > r) \mid U_0\right\} \\ &= (\Pr\{\|B_j - U_0\| > r \mid U_0\})^{N_B} \\ &= [1 - F(r)]^{N_B}. \end{aligned} \quad (124)$$

On the other hand, recall that $F(r)$ is also the CDF of $\|I_j - U_0\|$ and denote by $f_{I_0^{(K)}}(r)$ the pdf of $\|I_0^{(K)} - U_0\|$ given U_0 . A basic result in order statistics is that [4, chap. 3]

$$f_{I_0^{(K)}}(r) = \frac{N_I!}{(K-1)!(N_I-K)!} F^{K-1}(r) [1 - F(r)]^{N_I-K} \frac{\partial F(r)}{\partial r}. \quad (125)$$

Applying Bayes' rule to the probability of $e_2(N_I, \mathcal{K})$ as given by (77) conditioned on U_0 's position and using the expressions in (124) and (125), we obtain

$$\begin{aligned} \Pr\{e_2(N_I, \mathcal{K}) \mid U_0\} &= \\ &= \int_{-\infty}^{\infty} \Pr\left\{\|B_0^{(1)} - U_0\| > \mathcal{K}'r \mid I_0^{(K)} = r\right\} f_{I_0^{(K)}}(r) dr \\ &= \int_0^{r^*} [1 - F(\mathcal{K}'r)]^{N_B} \frac{N_I!}{(K-1)!(N_I-K)!} \\ &\quad \times F^{K-1}(r) [1 - F(r)]^{N_I-K} \frac{\partial F(r)}{\partial r} dr \end{aligned} \quad (126)$$

where we also used that $B_0^{(1)}$ is independent of $I_0^{(K)}$, and we defined $r^* := \min\{r \text{ s.t. } F(\mathcal{K}'r) = 1\}$ that is the relevant upper limit of the integral, since the integrand is null for $r > r^*$.

Applying Lemma 1 to the distribution $F(r)$, we obtain the following inequality valid in $(0, r^*)$:

$$F(\mathcal{K}'r) \leq \frac{(\mathcal{K}'r)^2}{R^2} = 4\mathcal{K}'^2 \frac{r^2}{4R^2} \leq 4\mathcal{K}'^2 F(r), \quad (127)$$

which upon substituting in (126) and changing variables $u = F(r)$, yields

$$\begin{aligned} \Pr\{e_2(N_I, \mathcal{K}) \mid U_0\} &\geq \\ &\int_0^{1/4\mathcal{K}'^2} (1 - 4\mathcal{K}'^2 u)^{N_B} \frac{N_I!}{(K-1)!(N_I-K)!} u^{K-1} [1 - u]^{N_I-K} du. \end{aligned} \quad (128)$$

We can expand the binomial $(1 - 4\mathcal{K}'^2)^{N_B}$ and interchange sum and integral to obtain

$$\begin{aligned} \Pr\{e_2(N_I, \mathcal{K}) \mid U_0\} &\geq \sum_{l=0}^{N_B} (-1)^l \binom{N_B}{l} (2\mathcal{K}')^{2l} \int_0^{1/4\mathcal{K}'^2} \frac{N_I! u^{l+K-1} [1 - u]^{N_I-K}}{(K-1)!(N_I-K)!} du \\ &:= \sum_{l=0}^{N_B} (-1)^l i_l, \end{aligned} \quad (129)$$

where we defined i_l as the absolute value of the l^{th} summand of the previous expression.

All these integrals can be evaluated in closed form. In particular, i_0 is given by

$$\begin{aligned} i_0 &:= \int_0^{1/4\mathcal{K}'^2} \frac{N_I!}{(K-1)!(N_I-K)!} u^{K-1} [1 - u]^{N_I-K} du \\ &= \sum_{j=K}^{N_I} \binom{N_I}{j} (1/4\mathcal{K}'^2)^j (1 - 1/4\mathcal{K}'^2)^{N_I-j}. \end{aligned} \quad (130)$$

The latter can be either computed directly or simply obtained by noting that the integral in (130) is the CDF of the K^{th} order statistic of a uniform random variable.

The summation in (130) can also be interpreted as the CDF of a binomial random variable with N_I trials and probability of success $\mathcal{K}'^{-2}/4$. As $N_I \rightarrow \infty$, the distribution converges to a normal and we have that

$$\begin{aligned} \lim_{N_I \rightarrow \infty} i_0 &= \lim_{N_I \rightarrow \infty} Q\left(\frac{K - N_I/4\mathcal{K}'^2}{\sqrt{N_I}/2\mathcal{K}'}\right) \\ &= \lim_{N_I \rightarrow \infty} Q\left(\frac{K - \rho^{2/\alpha} N_I/4\mathcal{K}^2}{\rho^{1/\alpha} \sqrt{N_I}/2\mathcal{K}}\right) \end{aligned} \quad (131)$$

where $Q(x) := \int_x^{\infty} 1/(\sqrt{2\pi}) \exp(-u^2/2) du$ is the cumulative Gaussian function, and we used the definition of \mathcal{K}' in the last equality. But note that if $K < \rho^{2/\alpha} N_I/4\mathcal{K}^2$, then the expression in (131) converges to 1, and this is true since the hypothesis $K/(\rho^{2/\alpha} N_I) \rightarrow 0$ implies that for any $4\mathcal{K}^2$ there exists a $K/(\rho^{2/\alpha} N_I)$ such that $(K/\rho^{2/\alpha} N_I) < 1/4\mathcal{K}^2$. Accordingly, we established that

$$\lim_{N_I \rightarrow \infty} i_0 = 1. \quad (132)$$

Consider now the remaining integrals that can be bounded as follows:

$$\begin{aligned} i_l &:= \binom{N_B}{l} (2\mathcal{K}')^{2l} \int_0^{1/4\mathcal{K}'^2} \frac{N_I! u^{l+K-1} [1-u]^{N_I-K}}{(K-1)!(N_I-K)!} du \\ &< \binom{N_B}{l} (2\mathcal{K}')^{2l} \int_0^1 \frac{N_I! u^{l+K-1} [1-u]^{N_I-K}}{(K-1)!(N_I-K)!} du \\ &= \binom{N_B}{l} (2\mathcal{K}')^{2l} \frac{N_I!}{(K-1)!(l+K) \dots (l+N_I)} \end{aligned} \quad (133)$$

where the inequality is obtained from the positivity of the integrand, and the second equality can be obtained after repeatedly integrating by parts. Moreover, it is easy to bound the factorials in the previous expression to obtain

$$i_l < \frac{1}{l!} \left(\frac{N_B \mathcal{K}'^2}{KN} \right)^l = \frac{1}{l!} \left(\frac{N_B \mathcal{K}^2}{K \rho^{2/\alpha} N_I} \right)^l. \quad (134)$$

But for $\rho^{2/\alpha} N_I / K \rightarrow \infty$ and $K \rightarrow \infty$, we have that $i_l \rightarrow 0$ for $l \neq 0$ for arbitrary \mathcal{K} . Taking limit in (129) and using the results summarized in (132) and (134), it follows that

$$\lim_{N_I \rightarrow \infty} \Pr\{e_2(N_I, \mathcal{K} | U_0)\} = 1. \quad (135)$$

To complete the proof, just note that (135) is a stronger result than the one desired, since the limit is conditioned on U_0 . ■

2) *Proof for event $e_1(N_I, \mathcal{K})$* : Note that if Lemma 1 is valid for all U_0 , it is also valid unconditionally when averaged over all possible U_0 's. From there, we obtain the inequality

$$\Pr\{\|U_0\| < r\} = \frac{r^2}{R^2} \leq 4 \Pr\{\|B_j - U_0\| < r\}, \quad (136)$$

for arbitrary B_j . But now note that by definition $\|B_j - U_0\| \geq \|B_0^{(1)} - U_0\|$; and consequently,

$$\begin{aligned} \Pr\{\|U_0\| < (\mathcal{K}/\rho) \|I_0^{(K)} - U_0\|\} \\ \leq 4 \Pr\{\|B_0^{(1)} - U_0\| < (\mathcal{K}/\rho) \|I_0^{(K)} - U_0\|\}. \end{aligned} \quad (137)$$

But the events involved in the previous inequality are the complements of $e_1(N_I, \mathcal{K})$ and $e_2(N_I, \mathcal{K})$, which implies that

$$1 - \Pr\{e_1(N_I, \mathcal{K})\} \leq 4[1 - \Pr\{e_2(N_I, \mathcal{K})\}]. \quad (138)$$

Since we just proved that $\Pr\{e_2(N_I, \mathcal{K})\} \rightarrow 1$, we deduce that $\Pr\{e_1(N_I, \mathcal{K})\} \rightarrow 1$. ■

3) *Proof for event $e_3(N_I, \mathcal{K})$* : Repeat steps (124) to (135) in the proof for $e_2(N_I, \mathcal{K})$. ■

D. Proof of Theorem 3

Let us first recall the following fact that will be used in the proof of claims [a] and [b].

Fact 1 If we have $\text{SINR}_0^k \rightarrow \infty$ in (57), then $\Pr\{I_k \in \mathcal{C}_0\} \rightarrow 1$. Indeed, if $\text{SINR}_0^k \rightarrow \infty$ then for all but a zero-measure set of fading channel realizations the packet transmitted by U_0 is correctly received by I_k . Likewise, if $\text{SINR}_0^k \rightarrow 0$ in (57), then $\Pr\{I_k \in \mathcal{C}_0\} \rightarrow 0$.

1) *Proof of claim [a]*: If $C_j^k \in \mathcal{C}_j$, then it successfully decoded B_j 's active-A packet in the previous slot. Consider SINR_j^k for the reception of B_j 's active-B packet by the user I_k in the previous slot that can be bounded by

$$\text{SINR}_0^k \leq \frac{P(U_0 \rightarrow I_k)}{N_0} = \frac{\rho P_0}{N_0} \frac{\|B_j\|^\alpha}{\|B_j - I_j^{(k)}\|^\alpha}, \quad (139)$$

where we just considered the noise term and neglected the other users' interference.

Assuming that $\|B_j - I_k\| / \|B_j\| > \epsilon$ and letting $N_I \rightarrow \infty$ in (139), we obtain

$$\lim_{N_I \rightarrow \infty} \text{SINR}_0^k \leq \lim_{N_I \rightarrow \infty} \frac{\rho P_0}{\epsilon N_0} = 0. \quad (140)$$

But now recall Fact 1 to claim that since $\text{SINR}_0^k \rightarrow 0$ we must have

$$\lim_{N_I \rightarrow \infty} \Pr\{I_k \in \mathcal{C}_j\} = \lim_{N_I \rightarrow \infty} P_e^1(\text{SINR}_0^k) = 0. \quad (141)$$

Thus, if $\|B_j - I_k\| / \|B_j\| > \epsilon$ for some ϵ , then $I_k \notin \mathcal{C}_j$ with probability 1. It thus follows that for those that did become cooperators, (81) must hold true. In particular, it is true for $C_j^{(K_j)}$. ■

2) *Proof of claim [b]*: We start by establishing a simple consequence of claim [a] in the following corollary:

Corollary 1 The event

$$e_4(N_I, \mathcal{K}) := \{\|U_0 - B_j\| > 2\|B_j - C_j^{(K_j)}\| \ \forall j = 1, \dots, N_B\} \quad (142)$$

has probability 1 as the number of idle users $N_I \rightarrow \infty$; i.e.,

$$\lim_{N_I \rightarrow \infty} \Pr\{e_4(N_I, \mathcal{K})\} = 1. \quad (143)$$

Proof: Consider the complement of $e_4(N_I, \mathcal{K})$, and use the union bound and Lemma 2 to claim that

$$1 - \Pr\{e_4(N_I, \mathcal{K})\} < 4N_B \Pr\{\|B_j\| < 2\|B_j - C_j^{(K_j)}\|\}. \quad (144)$$

But the latter goes to 0 according to Theorem 3-[a], with $\epsilon = 1/2$.

We now continue with the proof of claim [b].

Proof - [b]: According to Fact 1 it suffices to prove that $\text{SINR}_0^{(k)} \rightarrow \infty$ in probability, or equivalently,

$$\lim_{N_I \rightarrow \infty} \Pr\{\text{SINR}_0^{(k)} > \mathcal{K}'\} = 1 \quad \forall \mathcal{K}' > 0. \quad (145)$$

The inverse SINR is given by (71) and can be rewritten as

$$\begin{aligned} (\text{SINR}_0^{(k)})^{-1} &= S^{-1} \sum_{j=1}^{N_B} \sum_{i=0}^{K_j} \frac{P(C_{(j)}^i \rightarrow I_0^{(k)})}{P(U_0 \rightarrow I_0^{(k)})} \\ &+ S^{-1} \sum_{j=1}^{N_A-1} \frac{P(A_0^{(j)} \rightarrow I_0^{(k)})}{P(U_0 \rightarrow I_0^{(k)})} + \frac{N_0}{P(U_0 \rightarrow I_0^{(k)})} \end{aligned} \quad (146)$$

where we have just reordered the summands according to their closeness to U_0 .

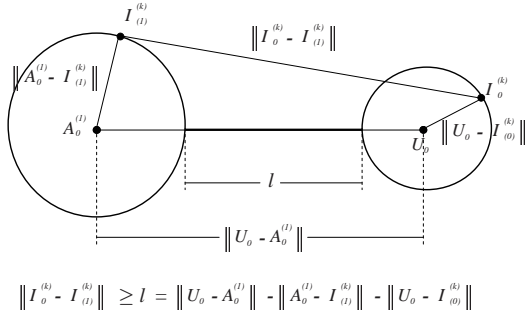

Fig. 13. Repeated use of the triangle inequality bounds the SNR with the distance quotients considered in Lemma 2.

We will first bound the noise term. To this end, supposing that $e_1(N_I, \mathcal{K})$ is valid, we obtain

$$\begin{aligned} \frac{N_0}{P(U_0 \rightarrow I_0^{(k)})} &= \frac{N_0}{\rho P_0} \frac{\|U_0 - I_0^{(k)}\|^\alpha}{\|U_0\|^\alpha} < \frac{N_0}{\rho P_0} \frac{\|U_0 - I_0^{(K_1)}\|^\alpha}{\|U_0\|^\alpha} \\ &< \frac{N_0 \rho^{\alpha-1}}{\mathcal{K}^\alpha P_0} < \frac{N_0}{\mathcal{K}^\alpha P_0}, \end{aligned} \quad (147)$$

where the first inequality follows since $\|U_0 - I_0^{(k)}\| < \|U_0 - I_0^{(K_1)}\|$ holds by definition for $k \leq K_1$, and in the last inequality we used that $\rho < 1$ and $\alpha > 2$.

Consider now the active-B users' interference terms. Since the transmitted powers are proportional to the distance to the AP as per [h3], we have

$$\begin{aligned} P^{1/\alpha}(C_{(j)}^i \rightarrow I_0^{(k)}) &= \frac{(P_0/K_j)^{1/\alpha} \|C_{(j)}^i\|}{\|C_{(j)}^i - I_0^{(k)}\|} \\ &< \frac{P_0^{1/\alpha} \|I_0^{(k)}\| + \|C_{(j)}^i - I_0^{(k)}\|}{K_j^{1/\alpha} \|C_{(j)}^i - I_0^{(k)}\|} \\ &= \frac{P_0^{1/\alpha}}{K_j^{1/\alpha}} \left[1 + \frac{\|I_0^{(k)}\|}{\|C_{(j)}^i - I_0^{(k)}\|} \right]. \end{aligned} \quad (148)$$

where the inequality follows from the triangle inequality applied to the triangle with vertices $AP, I_0^{(k)}, C_{(j)}^i$. Application of the same inequality to the triangle $AP, U_0, I_0^{(k)}$, yields

$$\|I_0^{(k)}\| < \|U_0\| + \|U_0 - I_0^{(k)}\| < \|U_0\| + \|U_0 - I_0^{(K)}\|, \quad (149)$$

where the second inequality follows from the definition of $I_0^{(k)}$ (the k^{th} closest to U_0 idle user), and the fact that $k \leq K$. Applying once again the triangle inequality to the triangles $I_0^{(k)}, B_0^{(j)}, C_{(j)}^i$ and $U_0, B_0^{(j)}, I_0^{(k)}$, yields (see also Fig. 13)

$$\begin{aligned} \|C_{(j)}^i - I_0^{(k)}\| &> \|U_0 - B_0^{(j)}\| - \|U_0 - I_0^{(k)}\| - \|B_0^{(j)} - C_{(j)}^i\| \\ &> \|U_0 - B_0^{(j)}\| - \|U_0 - I_0^{(K)}\| - \|B_0^{(j)} - C_{(j)}^{(K_j)}\| \\ &> 1/2 \|U_0 - B_0^{(j)}\| - \|U_0 - I_0^{(K)}\| \\ &> 1/2 \|U_0 - B_0^{(1)}\| - \|U_0 - I_0^{(K)}\|. \end{aligned} \quad (150)$$

In deriving the second inequality we used that $\|U_0 - I_0^{(k)}\| < \|U_0 - I_0^{(K)}\|$ and $\|B_0^{(j)} - C_{(j)}^i\| < \|B_0^{(j)} - C_{(j)}^{(K_j)}\|$ which follows by definition since $k \leq K$ and $i \leq K_j$. In the third inequality, we assumed the validity of $e_4(N_I, \mathcal{K})$; and the fourth one follows from $\|U_0 - B_0^{(j)}\| > \|U_0 - B_0^{(1)}\|$, which also is valid by definition.

If we also assume that the event $e_2(N_I, \mathcal{K})$ holds, we obtain that [c.f., (77), (150)]

$$\|C_{(j)}^i - I_0^{(k)}\| > (\mathcal{K}/2\rho^{1/\alpha} - 1) \|U_0 - I_0^{(K)}\|. \quad (151)$$

And the interfering power received at $I_0^{(k)}$ from $C_{(j)}^i$ can be bounded as [c.f., (148), (151)]

$$\begin{aligned} P^{1/\alpha}(C_{(j)}^i \rightarrow I_0^{(k)}) &< \frac{P_0^{1/\alpha}}{K_j^{1/\alpha}} \\ &\times \left[1 + \frac{\|U_0\|}{(\mathcal{K}/2\rho^{1/\alpha} - 1) \|U_0 - I_0^{(K)}\|} + \frac{1}{\mathcal{K}/2\rho^{1/\alpha} - 1} \right]. \end{aligned} \quad (152)$$

On the other hand, the power received at $I_0^{(k)}$ from U_0 is $P^{1/\alpha}(U_0 \rightarrow I_0^{(k)}) = (\rho P_0)^{1/\alpha} \|U_0\| / \|U_0 - I_0^{(k)}\| > (\rho P_0)^{1/\alpha} \|U_0\| / \|U_0 - I_0^{(K)}\|$, from where we arrive at

$$\begin{aligned} \left[\frac{P(C_{(j)}^i \rightarrow I_0^{(k)})}{P(U_0 \rightarrow I_0^{(k)})} \right]^{1/\alpha} &< \frac{1}{(\rho K_j)^{1/\alpha}} \left[\frac{1}{\mathcal{K}/2\rho^{1/\alpha} - 1} \right. \\ &\left. + \left(1 + \frac{1}{\mathcal{K}/2\rho^{1/\alpha} - 1} \right) \frac{\|U_0 - I_0^{(K)}\|}{\|U_0\|} \right]. \end{aligned} \quad (153)$$

Finally, note that if we assume that $e_1(N_I, \mathcal{K})$ is also true, we obtain the bound [c.f., (77), and (153)]

$$\frac{P(C_{(j)}^i \rightarrow I_0^{(k)})}{P(U_0 \rightarrow I_0^{(k)})} < \frac{1}{K_j \mathcal{K}^\alpha} f_B^\alpha(\mathcal{K}), \quad (154)$$

with $f_B(\mathcal{K})$ being a bounded function, since it is continuous and $\lim_{\mathcal{K} \rightarrow \infty} f_B(\mathcal{K}) = 4$.

Consider finally the active-A users' interference term that can be bounded by repeating the steps in (148) - (154), but instead of assuming the validity of the events $e_2(N_I, \mathcal{K})$ and $e_4(N_I, \mathcal{K})$ to go from (150) to (151), we assume that $e_3(N_I, \mathcal{K})$ is true. These steps yield

$$\left[\frac{P(A_0^{(j)} \rightarrow I_0^{(k)})}{P(U_0 \rightarrow I_0^{(k)})} \right]^{1/\alpha} < \left[\frac{1}{\mathcal{K} - 1} + \left(\frac{\mathcal{K}}{\mathcal{K} - 1} \right) \frac{\|U_0 - I_0^{(K)}\|}{\|U_0\|} \right] \quad (155)$$

from where the assumed validity of $e_1(N_I, \mathcal{K})$ leads to [c.f. (77) and (155)]

$$\left[\frac{P(A_0^{(j)} \rightarrow I_0^{(k)})}{P(U_0 \rightarrow I_0^{(k)})} \right] < \frac{1}{\mathcal{K}^\alpha} f_A^\alpha(\mathcal{K}), \quad (156)$$

with $f_A(\mathcal{K})$ bounded for the same reasons $f_B(\mathcal{K})$ is.

We can now combine the bounds in (147), (154) and (156) and the convexity of potential functions, $g(x) = x^\alpha$, with

$\alpha > 1$, to conclude that if the events $\{e_l(N_I, \mathcal{K})\}_{l=1}^4$ hold true, then

$$\begin{aligned} (\text{SINR}_0^{(k)})^{-1} &< N_B \frac{f_B^\alpha(\mathcal{K})}{SK^\alpha} + (N_A - 1) \frac{f_A^\alpha(\mathcal{K})}{SK^\alpha} + \frac{N_0}{\mathcal{K}^\alpha P_0} \\ &= \frac{1}{\mathcal{K}^\alpha} \left[(N_A - 1) f_B(\mathcal{K})/S + N_B f_A(\mathcal{K})/S + \frac{N_0}{P_0} \right] \\ &< \frac{\zeta}{\mathcal{K}^\alpha}, \end{aligned} \quad (157)$$

for some constant ζ . Consequently, the probability that (157) is satisfied is larger than the probability of all four $\{e_l(N_I, \mathcal{K})\}_{l=1}^4$ holding true, and thus

$$\Pr \left\{ (\text{SINR}_0^{(k)})^{-1} < C/\mathcal{K}^\alpha \right\} > \Pr \left\{ \bigcap_{l=1}^4 e_l(N_I, \mathcal{K}) \right\}. \quad (158)$$

To complete the proof, apply the union bound to the intersection in (158) to obtain

$$\Pr \left\{ (\text{SINR}_0^{(k)})^{-1} < C/\mathcal{K}^\alpha \right\} > 1 - \sum_{l=1}^4 (1 - \Pr\{e_l(N_I, \mathcal{K})\}). \quad (159)$$

But according to Lemma 2, the four probabilities considered converge to 1 as $N_I \rightarrow \infty$, and we obtain that

$$\lim_{N_I \rightarrow \infty} \Pr \left\{ (\text{SINR}_0^{(k)}) > \mathcal{K}' \right\} = 1, \quad (160)$$

with $\mathcal{K}' := \mathcal{K}^\alpha/\zeta$. But as noted before, (160) implies that the PEP converges to 0, and (82) follows readily. ■

$$\lim_{J \rightarrow \infty} \eta^{\text{OCRA}}(J, \kappa) = \lim_{J \rightarrow \infty} \eta^\kappa(J) \quad (161)$$

XI. NOTATION TABLE

Miscellaneous

ξ	Pathloss constant
α	Pathloss exponent
R	Network radius
\mathbb{N}	Set of natural numbers
\mathbb{Z}	Set of integer numbers
U_j	j^{th} user, $j \in [1, J]$
A_j	j^{th} active-A user, $j \in [1, N_A]$
B_j	j^{th} active-B user, $j \in [1, N_B]$
I_j	j^{th} idle user, $j \in [1, N_I]$

Users and users' sets

C_j^k	k^{th} cooperator of B_j , $k \in [0, K_j]$, $j \in [1, N_B]$
U_0	reference active-A user
C_0^k	k^{th} decoder of U_0 , $k \in [0, K_0]$
N	Nr. of interferers in SSRA
N_A, N_B, N_I	Nr. of active-A, active-B, idle users in OCRA
J	Total nr. of users
K_j	Nr. of U_j 's cooperators
\mathcal{J}	Set of users, $\mathcal{J} := \{U_j\}_{j=1}^J$
\mathcal{A}	Set of active-A users, $\mathcal{A} := \{A_j\}_{j=1}^{N_A}$
\mathcal{B}	Set of active-B users, $\mathcal{B} := \{B_j\}_{j=1}^{N_B}$
\mathcal{I}	Set of idle users, $\mathcal{I} := \{I_j\}_{j=1}^{N_I}$
\mathcal{C}_j	Set of B_j 's cooperators, $\mathcal{C}_j := \{C_j^k\}_{k=0}^{K_j}$
\mathcal{C}_0	Set of U_0 's decoders, $\mathcal{C}_0 := \{C_0^k\}_{k=0}^{K_0}$
$I_0^{(k)}$	k^{th} closest to U_0 idle user, $I_0^{(k)} \in \mathcal{I}$
$A_0^{(k)}$	k^{th} closest to U_0 active-A user, $A_0^{(k)} \in \mathcal{A}$
$B_0^{(k)}$	k^{th} closest to U_0 active-B user, $B_0^{(k)} \in \mathcal{B}$
$C_j^{(k)}$	k^{th} closest to B_j cooperators $C_j^{(k)} \in \mathcal{C}_j$

Transmission and reception

\mathbf{d}_{U_j}	U_j 's data packet
\mathbf{x}_{U_j}	U_j 's transmitted packet
\mathbf{c}	Pseudo-noise (PN) sequence
L	Nr. of bits in \mathbf{d}_{U_j}
T	Nr. of chips in \mathbf{x}_{U_j}
S	Spreading gain, $T = SL$
\mathcal{P}	Period of \mathbf{c}
$d_{U_j}(l)$	l^{th} bit of \mathbf{d}_{U_j} , $l \in [0, L - 1]$
$x_{U_j}(t)$	t^{th} chip of \mathbf{x}_{U_j} , $t \in [0, T - 1]$
$c(t)$	t^{th} chip of \mathbf{c} , $t \in \mathbb{Z}$
τ_{U_j}	U_j 's PN delay
$P(U_j)$	Power transmitted by U_j
$P(U_{j_2} \rightarrow U_{j_1})$	Power received at U_{j_1} from U_{j_2}
$P(U_j \rightarrow \text{AP})$	Power received at AP from U_j
$h(U_{j_2}, U_{j_1})$	Rayleigh block fading channel from U_{j_2} to U_{j_1}
$h(U_j)$	Rayleigh block fading channel from U_j to AP
$h_n(U_{j_1}, U_{j_2})$	Normalized channel $h(U_{j_1}, U_{j_2})/ h(U_{j_1}, U_{j_2}) $
\mathbf{z}_{U_j}	Block received by U_j
\mathbf{z}	Block received at the AP
$z_{U_j}(t)$	t^{th} chip of \mathbf{z}_{U_j} , $t \in [0, T - 1]$
$z(t)$	t^{th} chip of \mathbf{z} , $t \in [0, T - 1]$
$n(t)$	AWGN noise at t^{th} received chip, $t \in [0, T - 1]$
\mathbf{r}_{U_j}	decision vector for decoding U_j 's packet at AP
$r_{U_j}(l)$	l^{th} bit of \mathbf{r}_{U_j} , $l \in [0, L - 1]$
\mathbf{r}_{I_i}	decision vector for decoding U_0 's packet at I_i
$r_{I_i}(l)$	l^{th} bit of \mathbf{r}_{I_i} , $l \in [0, L - 1]$
$\tilde{n}(l)$	AWGN noise at l^{th} bit, $t \in [0, T - 1]$
P_0	Target received power
N_0	Noise variance
$\mathbb{I}(l; U_{j_0} \rightarrow U_{j_1}; U_{j_2})$	Interference of U_{j_2} to the communication of bit l from U_{j_0} to U_{j_1}
$\tilde{\gamma}_N, \tilde{\gamma}_n$	SINR in SSRA with N (n) active users
γ_N	instantaneous SINR in SSRA with N interferers

Queue parameters and success/failure probabilities

$P_e(\tilde{\gamma})$	PEP for γ SINR
$P_e^\kappa(\tilde{\gamma})$	PEP with κ -order diversity
$P_e^G(\tilde{\gamma})$	PEP with AWGN channel
HC	Hard collision, $\tau_{U_{j_0}} = \tau_{U_{j_1}}$ for some $j_1 \neq j_0$
SC	Soft collision, $\tilde{\mathbf{d}}_{U_j} \neq \mathbf{d}_{U_j}$ given HC ^c
$P_{\text{HC}}(N)$	HC probability with N active users (SSRA)
$P_{\text{SC}}(N)$	SC probability (SSRA)
$P_s(N)$	Successful detection probability (SSRA)
$P_{\text{HC}}(N_B)$	HC probability with N_B active-B users
$P_{\text{SC}}(N_A, N_B - 1)$	SC probability with N_A (N_B) active-A (B) users
P_s	Successful detection probability (SDP)
$P_s(N_A, N_B - 1)$	SDP with N_A (N_B) active-A (B) users
λ	Packet arrival rate per packet duration
p	Packet transmission probability
μ	Average departure rate
η	Aggregate throughput
$\eta(J, N_0/P_0, S, p)$	Throughput in SSRA, with J users, SNR P_0/N_0 , spreading gain S and transmission probability p

Queue parameters and success/failure probabilities (continued)

$\eta_{\max}(J, N_0/P_0, S)$	Maximum stable throughput (MST) in SSRA, with J users, SNR P_0/N_0 , spreading gain S
$\eta_\infty(J, N_0/P_0, S)$	SSRA Asymptotic MST
$\eta_\infty^G, \eta_{\max}^G, \eta_\infty^G$	throughput, MST, asympt. (AWGN channel)
$\eta_\infty^\kappa, \eta_{\max}^\kappa, \eta_\infty^\kappa$	Idem with κ -order diversity channel
$\eta_\infty, \eta_{\max}, \eta_\infty$	Idem with infinite order diversity channel

OCRA

κ	Maximum achievable diversity
ρ	Phase-A power reduction
κ_j	Diversity order
$C_j^{\kappa_0}$	B_j 's cooperators choosing PN shift κ_0
$N(B_j, \kappa_j)$	cardinality of $C_j^{\kappa_0}$
$\eta^{\text{OCRA}}(\cdot)$	OCRA's throughput
$\eta_{\max}^{\text{OCRA}}(\cdot \rho)$	ρ -conditional MST
$\eta_{\max}^{\text{OCRA}}(\cdot)$	MST
$\eta_\infty^{\text{OCRA}}(\cdot)$	Asymptotic MST
μ^{OCRA}	OCRA's departure rate

REFERENCES

- [1] "EIA/TIA Interim Standard, Wideband Spread Spectrum Digital Cellular System Dual-Mode Mobile Station-Base Station Compatibility Standard," *Qualcomm Inc.*, April 1992.
- [2] N. Abramson, "Multiple Access in Wireless Digital Networks," *Proceedings of the IEEE*, vol. 82, pp. 1360–1370, September 1994.
- [3] S. M. Alamouti, "A Simple Transmit Diversity Technique for Wireless Communications," *IEEE Journal on Selected areas in Communications*, vol. 16, pp. 1451–1458, October 1998.
- [4] N. Balakrishnan and A. Cohen, *Order Statistics and Inference Estimation Methods*. Academic Press Inc., 1991.
- [5] G. Dimic, N. D. Sidiropoulos, and R. Zhang, "Signal processing and queuing tools for MAC-PHY cross-layer design," *IEEE Signal Processing Magazine*, vol. 21, pp. 40–50, September 2004.
- [6] E. Dinan and B. Jabbari, "Spreading codes for direct sequence CDMA and wideband CDMA cellular networks," *IEEE Communications Magazine*, vol. 36, pp. 48–54, Sept. 1998.
- [7] K. S. Gilhousen, I. M. Jacobs, R. Padovani, A. J. Viterbi, L. A. Weaver, and C. E. Wheatley, "On the capacity of a cellular CDMA system," *IEEE Transactions on Vehicular Technology*, vol. 40, pp. 303–312, May 1991.
- [8] K. Joseph and D. Raychaudhuri, "Throughput of unslotted direct-sequence spread-spectrum multiple-access channels with block FEC coding," *IEEE Transactions of Communications*, vol. 41, pp. 1373–1378, September 1993.
- [9] J. N. Laneman and G. W. Wornell, "Distributed space-time-coded protocols for exploiting cooperative diversity in wireless networks," *IEEE Transactions on Information Theory*, vol. 49, pp. 2415–2425, October 2003.
- [10] R. Lin and A. P. Petropulu, "A New Wireless Network Medium Access Protocol Based on Cooperation," in *Proc. of 38th Asilomar Conf. on Signals, Systems, & Comp.*, vol. 2, pp. 1922–1926, Monterey, CA, USA, November 7–10, 2004.
- [11] R. Lin and A. P. Petropulu, "Cooperative Transmission for Random Access Wireless Networks," in *Proc. of Intl. Conf. on Acoust. Speech and Sig. Proc.*, Philadelphia, PA, USA, March 19–23, 2005.
- [12] R. Loynes, "The stability of a queue with non-independent interarrival and service times," *Mathematical Proceedings of the Cambridge Philosophical Society*, vol. 58, pp. 497–520, 1962.
- [13] R. K. Morrow and J. S. Lehnert, "Packet Throughput in Slotted Aloha DS/SSMA Radio Systems with Random Signature Sequences," *IEEE Transactions on Communications*, vol. 40, pp. 1223–1230, July 1992.
- [14] J. G. Proakis, *Digital Communications*. McGraw-Hill Higher Education, fourth ed., 2001.
- [15] R. Rao and A. Ephremides, "On the stability of interacting queues in a multi-access system," *IEEE Transactions on Information Theory*, vol. 34, pp. 918–930, September 1988.
- [16] T. S. Rappaport, *Wireless Communications*. Prentice Hall, 1996.
- [17] A. Ribeiro, X. Cai, and G. B. Giannakis, "Opportunistic multipath for bandwidth-efficient cooperative multiple access," *IEEE Trans. Wireless Commun.*, vol. 5, pp. 2321–2327, September 2006.
- [18] A. Ribeiro, N. D. Sidiropoulos, and G. B. Giannakis, "Achieving wireline random access throughput in wireless networking via user cooperation," in *Proc. IEEE Workshop on Signal Process. Advances in Wireless Commun.*, pp. 1033–1037, New York, NY, June 5–8, 2005.
- [19] A. Ribeiro, Y. Yu, G. B. Giannakis, and N. Sidiropoulos, "Increasing the throughput of spread-aloha protocols via long PN spreading codes," in *Proc. IEEE Int. Conf. Commun.*, vol. 5, pp. 3628–3631, Seoul, Korea, May 16–20, 2005.
- [20] G. Scutari, S. Barbarossa, and D. Ludovici, "Cooperation diversity in multihop wireless networks using opportunistic driven multiple access," in *Proc. of the IEEE International Workshop on Signal Processing Advances for Wireless Communications*, pp. 170–174, Rome, Italy, June, 2003.
- [21] A. Sendonaris, E. Erkip, and B. Aazhang, "User cooperation diversity - part I: system description," *IEEE Transactions on Communications*, vol. 51, pp. 1927–1938, Nov. 2003.
- [22] A. Sendonaris, E. Erkip, and B. Aazhang, "User cooperation diversity - part II: implementation aspects and performance analysis," *IEEE Transactions on Communications*, vol. 51, pp. 1939–1948, Nov. 2003.
- [23] M. K. Tsatsanis, R. Zhang, and S. Banerjee, "Network-assisted diversity for random access wireless networks," *IEEE Transactions on Signal Processing*, vol. 48, pp. 702–711, March 2000.
- [24] B. Tsybakov and V. Mikhailov, "Ergodicity of a Slotted Aloha System," *Probl Inf. Transm.*, vol. 15, April 1980. (translated from Russian original in *Probl Peredachi Inf.* 15, 4 (Oct.-Dec. 1979), 72–87).
- [25] A. J. Viterbi, *CDMA Principles of Spread Spectrum Communication*. Addison-Wesley Wireless Comms. Series, 1995.
- [26] Z. Wang, S. Zhou, and G. B. Giannakis, "Joint Coding-Precoding with Low-Complexity Turbo-Decoding," *IEEE Transactions on Wireless Communications*, vol. 3, pp. 832–842, May 2004.
- [27] J. Yu and A. P. Petropulu, "Cooperative Transmissions for Random Access Wireless Network with MPR Channels," in *Proc. of the Conf. on Info. Sci. & Systems*, The Johns Hopkins Univ., Baltimore, MD, March 2005.
- [28] Y. Yu, A. Ribeiro, N. D. Sidiropoulos, and G. B. Giannakis, "Cooperative random access with long PN spreading codes," in *Proc. Int. Conf. Acoustics, Speech, Signal Process.*, vol. 3, pp. 517–520, Philadelphia, PA, March 18–23, 2005.

PLACE
PHOTO
HERE

Alejandro Ribeiro (SM'05) received his B.Sc. degree in Electrical Engineering from Universidad de la Republica Oriental del Uruguay, Montevideo, Uruguay in 1998. Since May 2003 he has been working towards his Ph.D. degree in the Department of Electrical and Computer Engineering, University of Minnesota, Minneapolis, MN where he received his M.Sc. degree in Electrical Engineering in 2005.

From 1998 to 2003 he was a member of the Technical Staff at Bellsouth Montevideo. His research interests lie in the areas of communication theory, signal processing and networking. His current research focuses on wireless cooperative communications, random access, wireless ad hoc and sensor networks, and distributed signal processing. Mr. Ribeiro received best student paper awards at ICASSP 2005 and ICASSP 2006. Mr Ribeiro is a Fulbright Scholar.

PLACE
PHOTO
HERE

Georgios B. Giannakis (F'97) received his Diploma in Electrical Engineering from the National Technical University of Athens, Greece, 1981. From September 1982 to July 1986 he was with the University of Southern California (USC), where he received his M.Sc. in Electrical Engineering, 1983, M.Sc. in Mathematics, 1986, and Ph.D. in Electrical Engineering, 1986. After lecturing for one year at USC, he joined the University of Virginia in 1987, where he became a professor of Electrical Engineering in 1997. Since 1999 he has been a professor with the Department of Electrical and Computer Engineering at the University of Minnesota, where he now holds an ADC Chair in Wireless Telecommunications.

His general interests span the areas of communications and signal processing, estimation and detection theory, time-series analysis, and system identification subjects on which he has published more than 250 journal papers, 400 conference papers and two edited books. Current research focuses on diversity techniques for fading channels, complex-field and spacetime coding, multicarrier, ultra-wide band wireless communication systems, cross-layer designs and sensor networks.

G. B. Giannakis is the (co-) recipient of six paper awards from the IEEE Signal Processing (SP) and Communications Societies (1992, 1998, 2000, 2001, 2003, 2004). He also received Technical Achievement Awards from the SP Society in 2000 and from EURASIP in 2005. He served as Editor in Chief for the IEEE SP Letters, as Associate Editor for the IEEE Trans. on Signal Proc. and the IEEE SP Letters, as secretary of the SP Conference Board, as member of the SP Publications Board, as member and vice-chair of the Statistical Signal and Array Processing Technical Committee, as chair of the SP for Communications Technical Committee and as a member of the IEEE Fellows Election Committee. He has also served as a member of the IEEE-SP Societys Board of Governors, the Editorial Board for the Proceedings of the IEEE and the steering committee of the IEEE Trans. on Wireless Communications.

PLACE
PHOTO
HERE

Nikolaos D. Sidiropoulos (M'92-SM'99) received the Diploma degree in electrical engineering from the Aristotelian University of Thessaloniki, Thessaloniki, Greece, in 1988 and the M.S. and Ph.D. degrees in electrical engineering from the University of Maryland, College Park (UMCP), in 1990 and 1992, respectively.

From 1988 to 1992, he was a Fulbright Fellow and a Research Assistant at the Institute for Systems Research (ISR), UMCP. From September 1992 to June 1994, he served his military service as a Lecturer in the Hellenic Air Force Academy. From October 1993 to June 1994, he alsowas a Member of the Technical Staff, Systems Integration Division, G-Systems, Ltd., Athens, Greece. He was a Postdoctoral Fellow from 1994 to 1995 and Research Scientist from 1996 to 1997 at ISR-UMCP, an Assistant Professor with the Department of Electrical Engineering, University of Virginia, Charlottesville, from 1997 to 1999, and an Associate Professor with the Department of Electrical and Computer Engineering, University of Minnesota, Minneapolis, from 2000 to 2002. He is currently a Professor with the Telecommunications Division of the Department of Electronic and Computer Engineering, Technical University of Crete, Chania, Crete, Greece, and Adjunct Professor at the University of Minnesota. His current research interests are primarily in signal processing for communications and multiway analysis. He is an active consultant for industry in the areas of frequency-hopping systems and signal processing for xDSL modems.

Dr. Sidiropoulos is a member of both the Signal Processing for Communications (SPCOM) and Sensor Array and Multichannel Signal Processing (SAM) Technical Committees of the IEEE Signal Processing Society and currently serves as an Associate Editor for the IEEE TRANSACTIONS ON SIGNAL PROCESSING. From 2000 to 2002, he also served as Associate Editor for the IEEE SIGNAL PROCESSING LETTERS. He received the NSF/CAREER award (Signal Processing Systems Program) in June 1998 and an IEEE Signal Processing Society Best Paper Award in 2001.

PLACE
PHOTO
HERE

Yingqun Yu received his B.S. degree from the Department of Electronic Science and Engineering, Nanjing University, Nanjing, China, in 1997 and M.S. degree from the Department of Electronic Engineering, Tsinghua University, Beijing, China, in 2000. He is currently a Ph.D. student at the Department of Electrical and Computer Engineering, University of Minnesota.

Since May 2002, he has been a Research Assistant with the Department of Electrical and Computer Engineering, University of Minnesota. His research interests include information theory, wireless communications and networking, and signal processing for communications.