

University of Pennsylvania

Electrical & Systems Engineering Undergraduate Laboratories

ESE 112: Introduction to Electrical & Systems Engineering

Sansern Somboonsong

January 2008

Lab 1: Introduction to Electrical Systems

Objective

Provide students with basic concepts of electrical circuit theory using robots and their underlying electrical and mechanical system.

Background

Robotics is the science of designing and manufacturing robots, which requires the understanding and integration of electrical, mechanical, controls, software, and sometimes, biological systems. Robots are systems consisting of actuators, sensors, and computers that perform some task(s). Robots replace humans in jobs that require speed, accuracy, repetitive motion, and jobs that are considered dangerous to humans. There are many different kinds of robots, some perform specific tasks repetitively such as a robotic arm and some are more mobile and autonomous such as NASA's Mars Rover and some take the human form like the Honda's ASIMO. Robotics is a far-reaching topic involving many disciplines of engineering and sciences. This lab will introduce you to the concept of actuators (mechanical device for moving or controlling a mechanical system) and sensors, the two basic and essential parts of any robotic systems. Robots use sensors to get information and its actuators (i.e. motor) to move and accomplish some task. Of course, not all robots move freely and they only need to sense what is necessary to complete its task. Most robots today are designed for specific purpose; the goal is to make a programmable robot that is flexible enough to do just about anything.



Figure 1 – Examples of Robots. (left to right) Robotic arm, Mars Rover, ASIMO.

Sensors convert measurement of temperature, touch, light, acceleration, or magnetic field into electrical signals. They may be used to measure different things but one thing that they all have in common is the fact that they are electronic devices that are designed to work in electrical circuits. To understand and be able to design sensor circuits, it is essential to have the basic knowledge of electrical systems.

Voltage, Current, and Resistance

Voltage is the potential difference, in other words, the difference in the electrical charge of two points measured in Volts (V). Charges will flow when there is electrical conductivity through some material. This flow is called current and it is measured in Amps (A). The degree of difficulty of the flow or the capacity of the material to impede the flow of current is called the resistance, measured in Ohms (Ω). The analogy of the water dam will further emphasize the relationship between voltage, current and resistance.

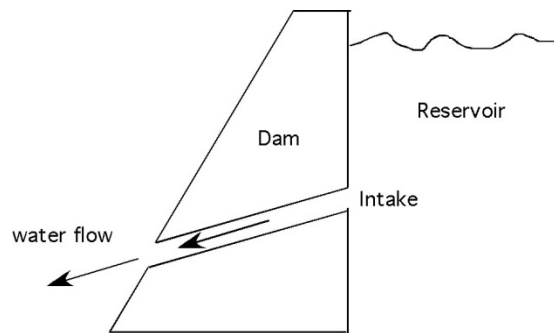

Figure 2 – Analogy of Water Dam

The level of water in the reservoir is analogous to the potential energy (voltage), the higher the water level, the greater will be the volume of water displaced (current). The resistance is like the size of the opening in the dam that allows water to flow, the larger the opening, the greater the flow. However, the larger the resistance, the harder it is for the charge to flow. Lastly, the current is the amount of water that flows through the opening in the dam wall. Holding the resistance constant, higher voltage (water level) will result in higher current (water flow).

A simple circuit consisting of a resistor and a power source (battery) can be constructed as shown in figure 3.

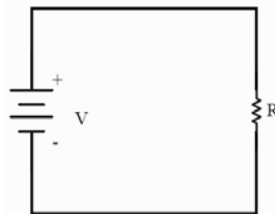

Figure 3a. – Simple Battery and Resistor Circuit.

Notice how the battery, resistor, and the connection are represented. The battery represents a voltage (V) and the resistor represents a resistance (R), in the case of this circuit, the current will flow clockwise in the loop through the resistor. Another way to better understand the current flow is to visualize the positive charge at the positive terminal of the battery wants to get to the negative charge at the negative terminal of the battery. This can only accomplish that by going through the resistor thus creating a flow of current. How much current?

Ohm's Law, Kirchhoff's Voltage Law (KVL), and Kirchhoff's Current Law (KCL)

Ohm's Law states that the current passing through two points is directly proportional to the voltage and inversely proportional to the resistance between them.

$$I = \frac{V}{R}$$

By this equation, given that the voltage across a 1000Ω ($1K\Omega$) resistor is $10V$ the current passing through the resistor can be calculated to be $0.01 A$ ($10mA$).

Two more laws of circuit theory are necessary for circuit analysis. Kirchhoff's Voltage Law (KVL) and Kirchhoff's Current Law (KCL) are based on the conservation of energy and are the fundamentals of circuit theory. KVL states that the sum of the voltage around a closed circuit must be zero.

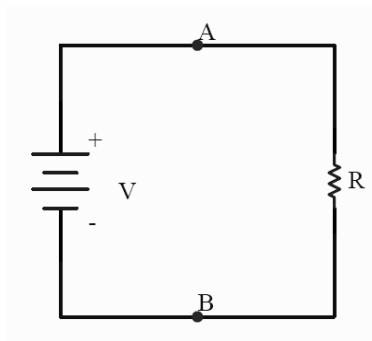

Figure 3b. – Simple Battery and Resistor Circuit.

KVL and Ohm's law yields the following equation for the circuit above.

$$0 = -V + IR$$

Another way to look at this circuit is to remember the definition of voltage which is the potential difference between two points. The potential difference between point A and B can be the voltage across the battery or the voltage across the resistor (R), in other words, the two voltages must be equal. This gives us the following equation:

$$V = IR$$

Which is identical to Ohm's law and to the equation obtained using KVL.

KCL states that at any point in an electrical circuit, the sum of current flowing into a node (point) equal to the current exiting.

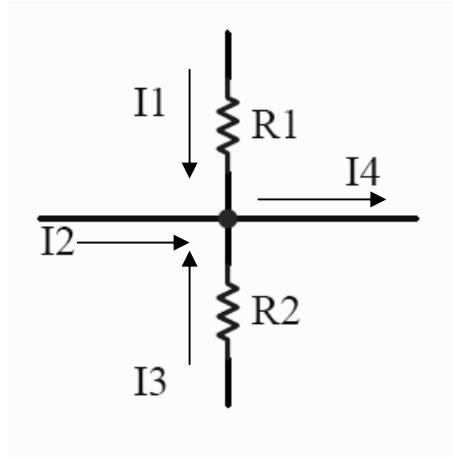

Figure 4. – Node with Four Branchs.

The diagram above illustrates a node with four branches with three incoming and one outgoing current flow. KCL agrees with our intuition that all the current that comes in must go out. Using KCL, the following equation can be formulated:

$$I_1 + I_2 + I_3 = I_4$$

Equivalent Resistance

More often than not, there will be several resistors in a circuit. Finding the equivalent resistance simplify circuits and make the analysis process easier. When two resistors are put in series (see diagram below) it is equivalent to a circuit with one resistor with a value equal to the sum of the two resistors.

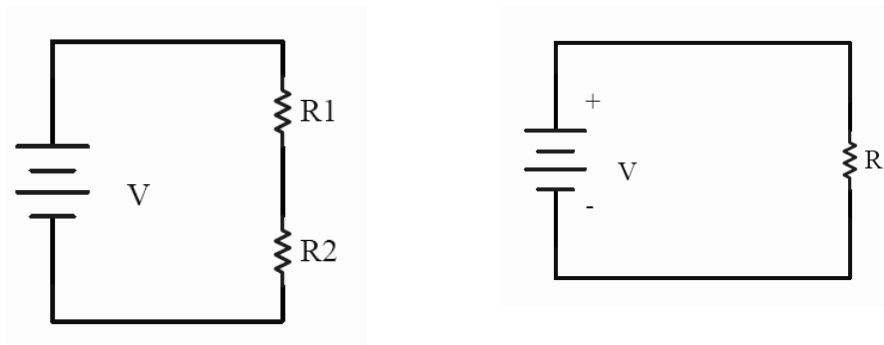

Figure 5. – Resistors in Series and Equivalent Circuit

$$R = R_1 + R_2$$

In the case of two resistors in parallel, the inverse of the equivalent resistance is equal to the sum of the inverse resistances.

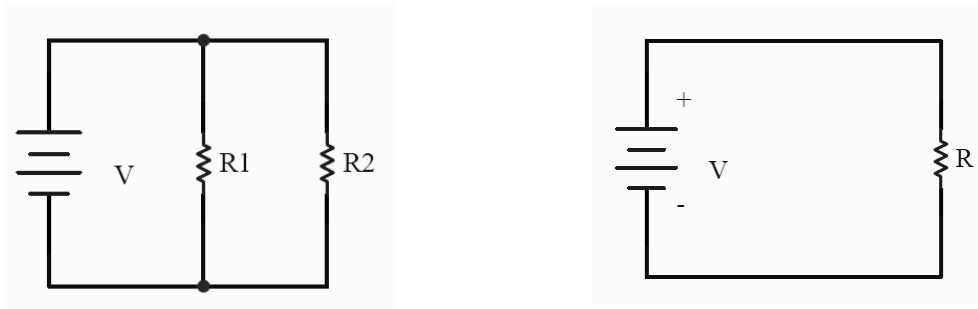

Figure 6. – Resistors in Parallel and Equivalent Circuit

$$\frac{1}{R} = \frac{1}{R_1} + \frac{1}{R_2}$$

Voltage Divider Circuit

One easy way to get different voltage level from one supply is through the use of a voltage divider circuit. This circuit consists of two resistors in series as shown in the figure below:

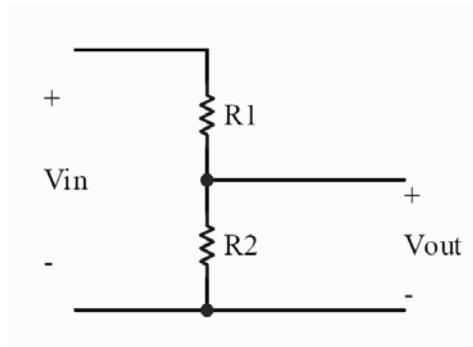

Figure 7. – Voltage Divider Circuit.

Using the knowledge of Ohm's Law and resistors in series, the following equation can be obtained from the circuit above:

$$V_{in} = (R_1 + R_2)I$$

Or equivalently

$$I = \frac{V_{in}}{(R_1 + R_2)}$$

Vout is the voltage across R₂:

$$V_{out} = IR_2$$

$$V_{out} = V_{in} \frac{R_2}{(R_1 + R_2)}$$

Holding V_{in} and R₂ constant, different voltage levels can be obtained from changing R₁. When R₁ is zero, V_{out} equals V_{in}. When R₁ is very large, V_{out} approaches zero. What is V_{out} when R₁ equals R₂?

A potentiometer (pot) is a variable resistor that can be used as a voltage divider. The diagram on the bottom left shows the circuit representation of a potentiometer and its equivalent circuit on the right with R₁ being a variable resistor.



Figure 8 – Potentiometer (Left) and Circuit Representation (Right)

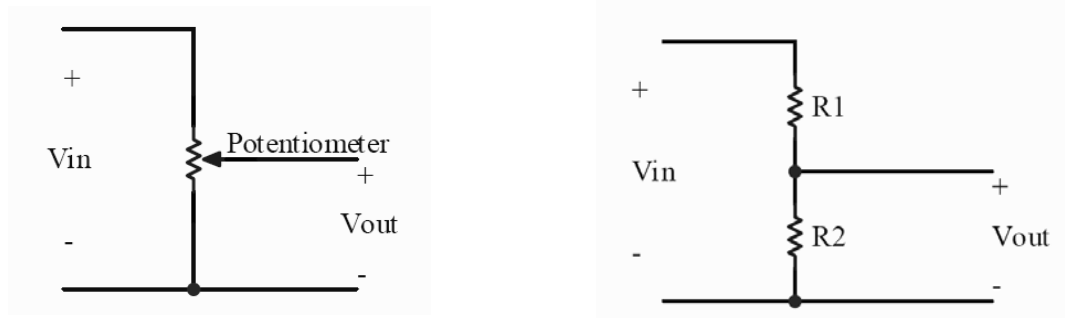

Figure 9 – Potentiometer Circuit (Left) and Equivalent Voltage Divider Circuit (Right)

The functionality of the potentiometer is slightly different from the example of the voltage divider given prior. The Potentiometer divides resistance into two parts, R₁ and R₂ which always add up to the rated resistance. To adjust the resistance, a small screwdriver can be used to turn the circular knob on the potentiometer. For example, a 10K pot would have a resistance of 10K Ω between pin 1 and 3. The resistance between pin 1 and 2 ranges from 0-10 k Ω as the knob is adjusted which is also true for the resistance between pin 2 and 3. The two resistances (R₁ and R₂) will always add up to 10k Ω.

Power

Along with voltage, current, and resistance, power is one of the fundamental measurements in electronics. Power is the rate at which energy is transferred in a circuit measured in watts (W). When current flows in a circuit with some resistance, work is done. The power (P) consumed or delivered by a component (battery, resistor, motor) is measured by the current (I) through the component times the voltage (V) across that same component.

$$P = IV$$

Using Ohm's law, we can rearrange the above equation to produce two other useful forms when either the voltage or current are unknown.

$$P = I^2R; \quad P = \frac{V^2}{R}$$

Using a Digital Multi-Meter (DMM)

In several labs in this course, electrical measurements will be required and can be accomplished with the use of a digital multi-meter or DMM. The DMM is a very useful device for measuring voltage, current, resistance, and electrical continuity. Some DMMs have more advanced features such as measuring capacitance, temperature, transistors characteristics, etc. Learning how to use the DMM properly will be important and will prevent any damages to the equipment, circuit, and user. For all our intended purposes, we will be working with DC (direct current) voltage (V) and current (A). As you may have already learned, voltage is the potential difference between two points. To measure the voltage of your battery, change the setting of the DMM to DC Voltage, make sure the leads are plugged into the correct terminals, touch the black lead to the negative (-) terminal and the red lead to the positive (+) terminal of the battery.

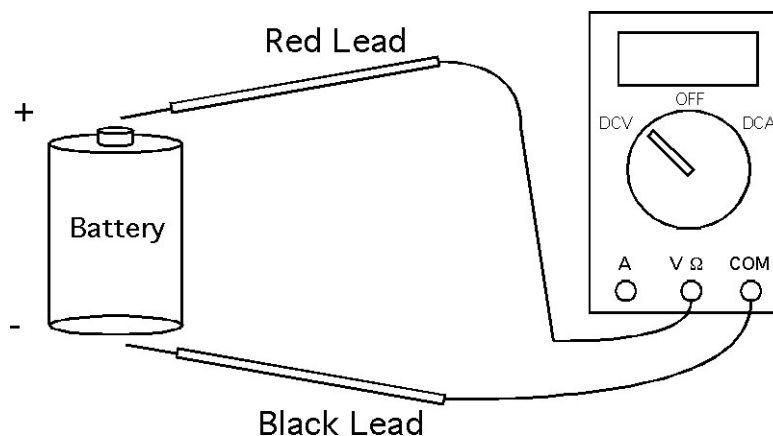

In order to measure voltage with the DMM, you must connect them in parallel with the component you wish to measure. To measure the current through a circuit, you must insert the DMM in series with the circuit such that it would be an open circuit if you were to remove

the multimeter. Also, when measuring the resistance with a DMM, the circuit must be off and any power sources removed. You will obtain a resistance value if measured with an active circuit but it will be meaningless for all intended uses in this lab.

Electro-Mechanical Mouse Lab

In robotics, navigating new domains is a very difficult task; walking in circles, getting stuck on obstacles, etc. are problems that robots often encounter. In some situations, it is often the case that many sensors no longer work. For example, in a fire, a vision system is often rendered useless. In the animal kingdom, different species employ many different strategies to solve this problem. Mice, which are almost blind, tend to use their whiskers and cautiously run along baseboards and walls using a very simple yet very effective wall-following algorithm. In this lab you will build a simple “robotic” mouse and conduct some basic tests on your robot.

Material

Wall Hugging Mouse Kit
C batteries
Screwdrivers (flat and Phillips head)
Wire strippers
Scissors
Digital Multi-Meter (DMM)
Electrical tape
Potentiometer

Prelab

1. Obtain the necessary hardware to assemble the mouse. This includes the mouse kit, battery, screwdrivers, and wire strippers.
2. The Wall Hugging Mouse kit comes with its own set of instructions. Follow these instructions to assemble the mouse (whiskers and paint optional)
3. Test it by having it run along a wall or around a box.
4. Given $R_1=1K\Omega$, $R_2=10K\Omega$, $R_3=3.3K\Omega$, and $V=5V$. Find the current going through R_1 .

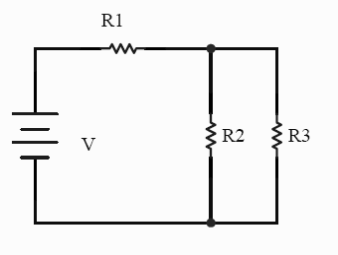

5. Given $V_{in}=10V$, find R_1 and R_2 that will yield V_{out} of 3.5V.

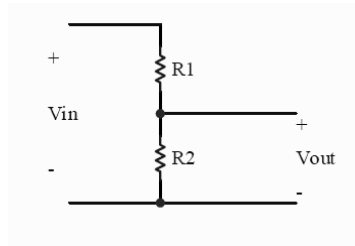

6. Why are most sensors electronic devices?

Lab Instructions

1. Measure and record the voltage of the battery.
2. Explain to the lab instructor how the robot works.
3. Identify the positive and negative input supply of the mouse.
4. Add an additional battery, first in parallel, and then in series. Record any changes.
5. Obtain a potentiometer, measure the resistance with the DMM, and draw the equivalent circuit representation of the potentiometer. Make sure to include the resistance value(s) in your diagram.
6. Rewire the mouse to use one battery and be able to change the speed using a potentiometer. Draw a circuit diagram of the mouse circuitry with the potentiometer.
7. Using a screwdriver, turn the potentiometer to observe the change in motor speed. Record the voltage to the motors and resistance of the potentiometer. Remember the rules for using the DMM in the background.
8. Form into groups. Use the components available to create one mouse that travels straight and can avoid objects on both sides of itself. You may use no new components but as many as you would like from the two completed mice.

Questions

1. How does the Wall Hugging Mouse work?
2. Draw and explain the mouse's electrical circuit.
3. How would you make it go faster?
4. What design changes did you have to make to have this robot mouse move around a room freely, avoiding walls no matter on which side they are? Explain fully and provide a schematic of the circuit.
5. Could you make the mouse go backwards and retain its functionalities?
6. What changes could you make to the gearing to make it move faster?
7. What changes could you make to the gearing to make it climb hills better?
8. Look up some definitions of a robot. Is the mouse you built a robot? If so explain why, if not what would have to be added for it to qualify as a robot? Remember to cite your source.
9. Given that a standard C battery contains 7600 mAh (milliampere-hour), how long should the mouse last based at each of the speeds that you measured.