

Differential Amplifier Cont.

- Differential amplifier with emitter resistors
- Single-ended output
- Common mode rejection ratio (CMRR)

Quick Review

CM DC

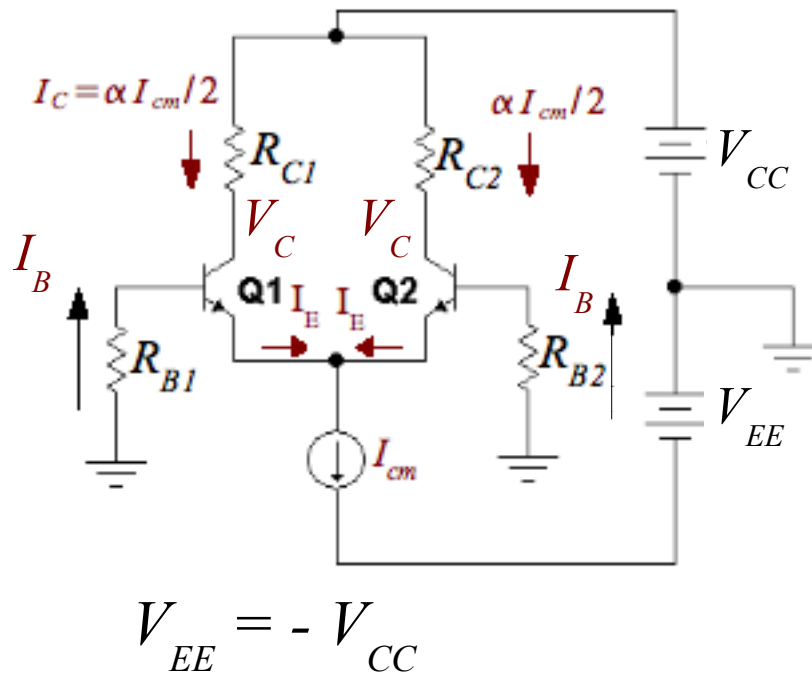

DC Bias is ALWAYS
COMMON MODE

$$R_{C1} = R_{C2} = R_C = \frac{V_{CC} - V_C}{\alpha \frac{I_{CM}}{2}}$$

$$R_{B1} = R_{B2} = R_B = \text{large}$$

Quick Review

DM AC – Small Signal

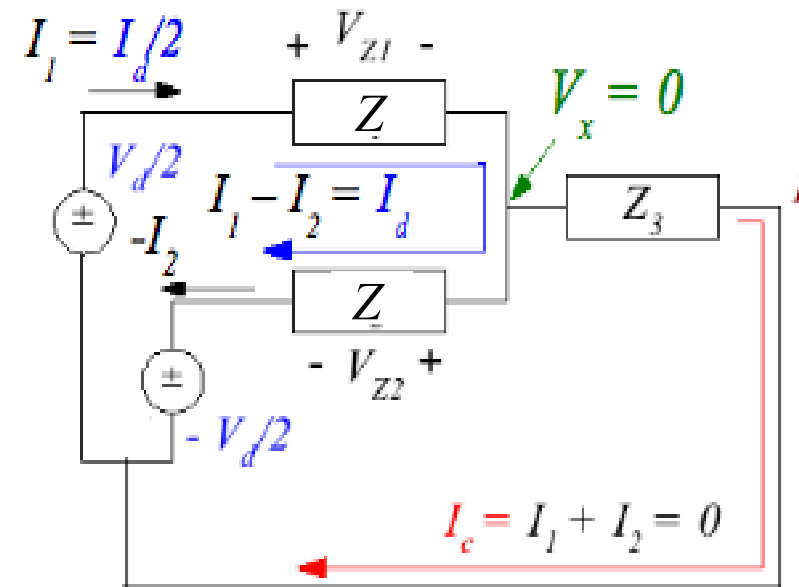
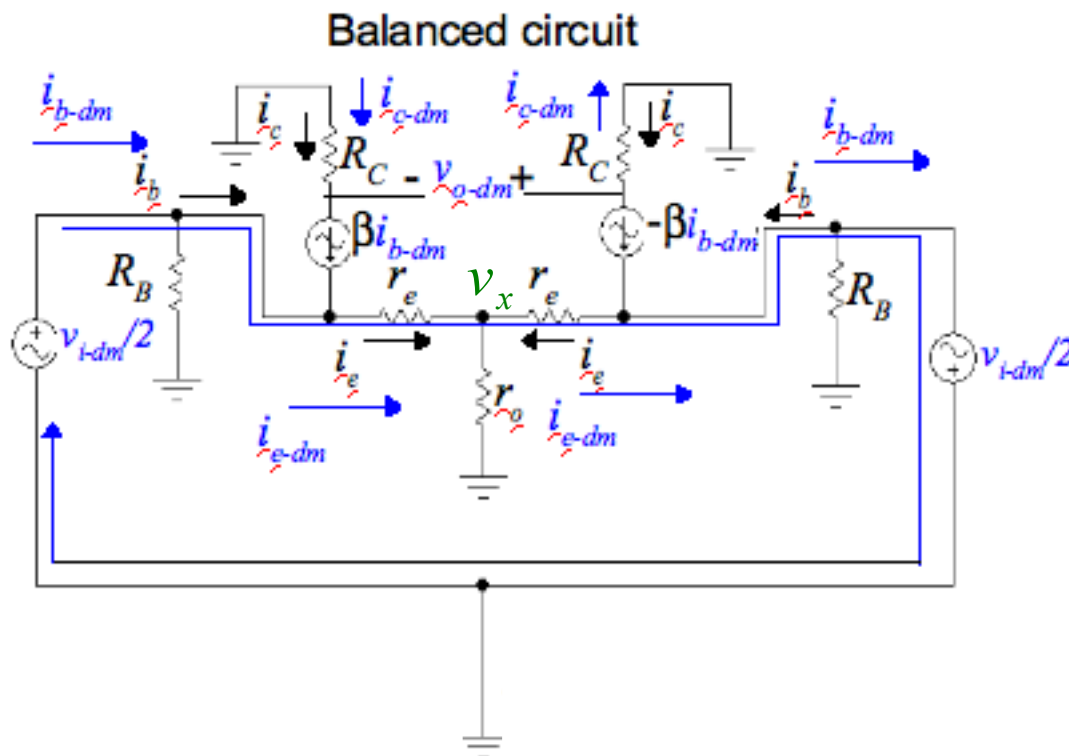

Quick Review

CM AC – Small Signal

Balanced circuit

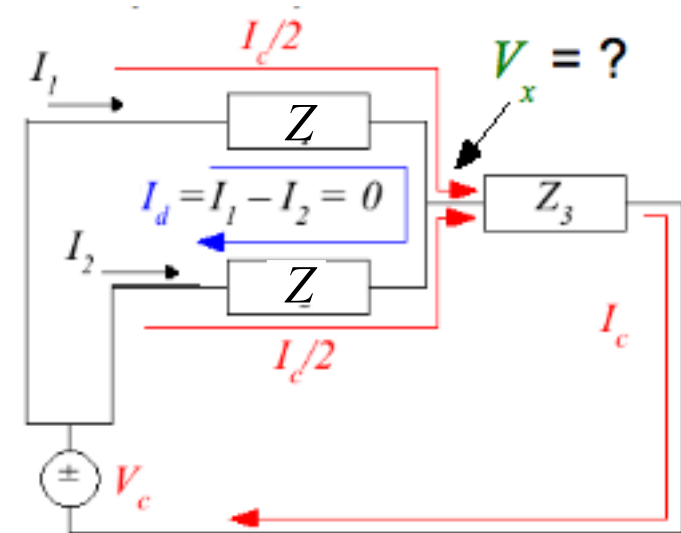
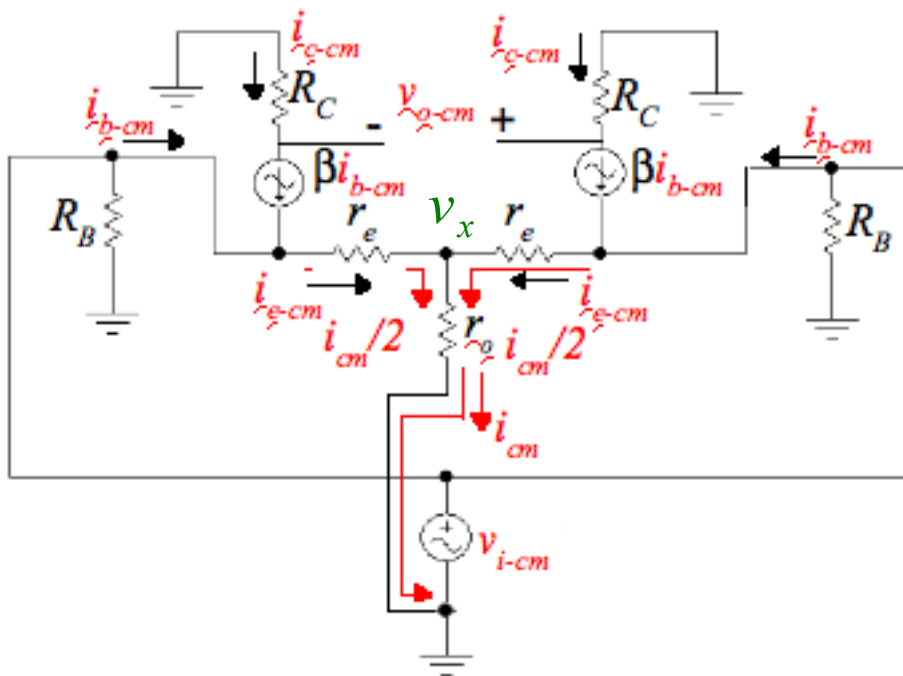



Quick Review

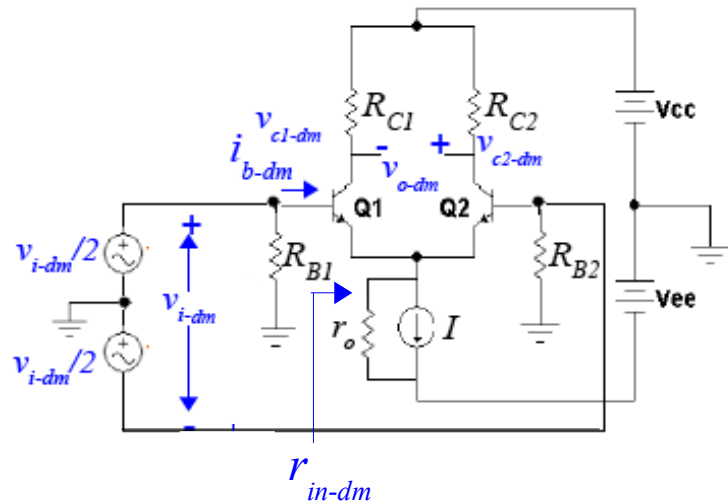

Differential mode:

$$r_{in-dm} = 2(\beta + 1)r_e$$

Differential DM Voltage gain:

$$A_{v-dm} = \frac{v_{o-dm}}{v_{i-dm}} \approx \frac{R_C}{r_e}$$

Single-Ended DM Voltage gain:

$$A_{v-dm1} = -A_{v-dm2} = \frac{v_{c1-dm}}{v_{i-dm}} \approx -\frac{R_C}{2r_e}$$

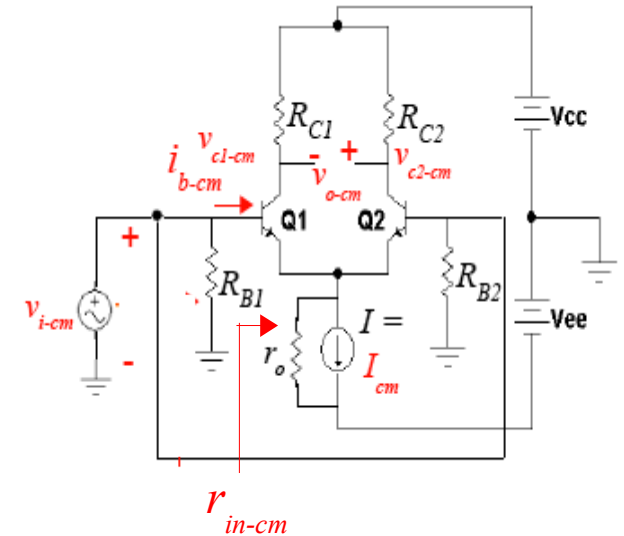

Common mode:

$$r_{in-cm} = (\beta + 1) \left(\frac{r_e}{2} + r_o \right) \approx (\beta + 1)r_o$$

Differential CM Voltage gain:

$$A_{v-cm} = \frac{v_{o-cm}}{v_{i-cm}} = 0$$

Single-Ended CM Voltage gain:

$$A_{v-cm1} = A_{v-cm2} = \frac{v_{c1-cm}}{v_{i-cm}} \approx -\frac{R_C}{2r_o}$$

Differential Amplifier With Emitter Resistors

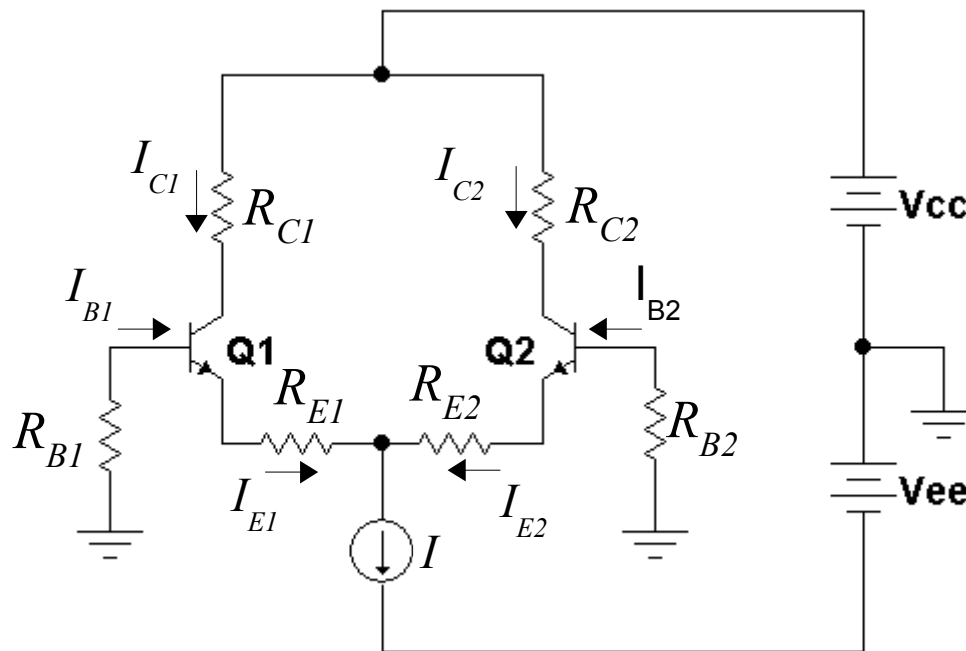

Balance assumed:

$$R_{C1} = R_{C2} = R_C$$

$$R_{E1} = R_{E2} = R_E$$

$$R_{B1} = R_{B2} = R_B$$

$Q1 = Q2$ (Matched Pair)

Differential Mode Analysis ($v_{i-cm} = 0$)

Balanced circuit

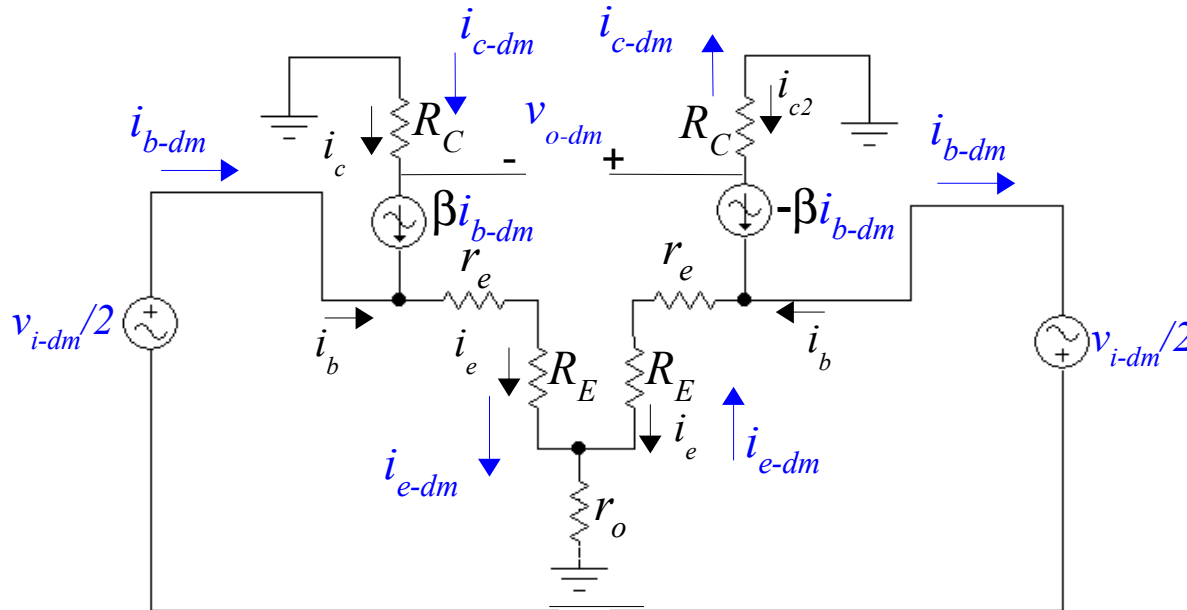

NOTE:

1. r_o for Q1 and Q2 are ignored.
2. Both R_B 's are ignored.

$$r_{in-dm} = 2(\beta + 1)(r_e + R_E)$$

Differential DM Voltage gain:

$$A_{v-dm} = \frac{v_{o-dm}}{v_{i-dm}} \approx \frac{R_C}{(r_e + R_E)}$$

Single-Ended DM Voltage gains:

$$A_{v-dm1} = \frac{v_{c1-dm}}{v_{i-dm}} = \frac{-\beta R_C}{2(\beta + 1)(r_e + R_E)}$$

$$A_{v-dm2} = \frac{v_{c2-dm}}{v_{i-dm}} = \frac{\beta R_C}{2(\beta + 1)(r_e + R_E)}$$

Differential Mode Analysis - Continued

Balanced circuit

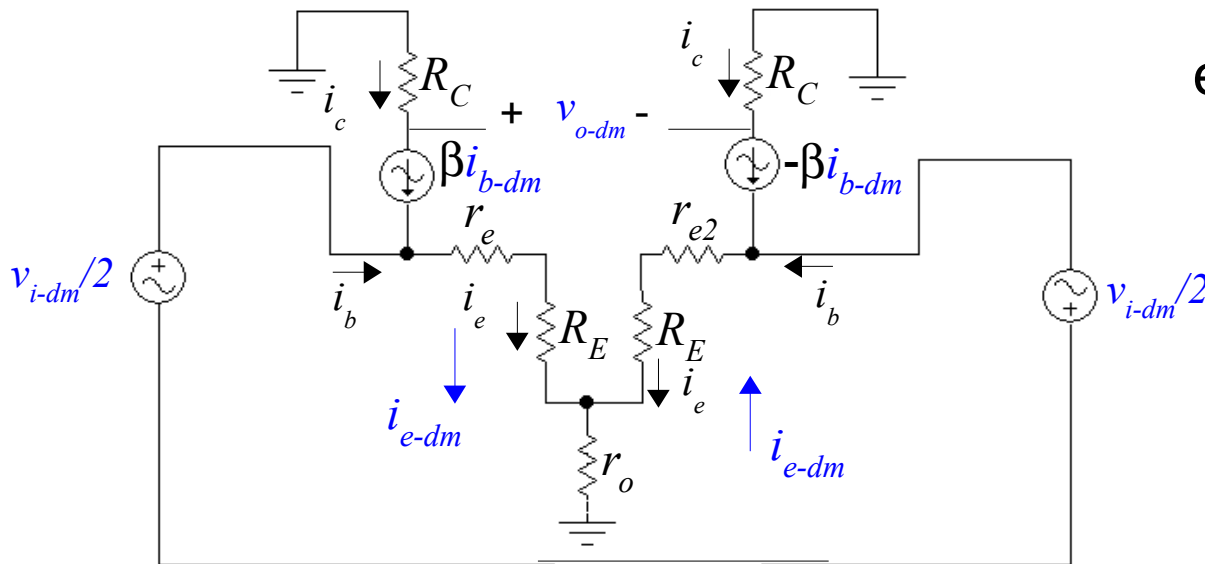

The collector-to-ground (single-ended) gain of the Q2 stage is:

$$A_{v-dm2} = \frac{v_{c2-dm}}{v_{i-dm}} \approx \frac{R_C}{2(r_e + R_E)}$$

Experimentally (or MultiSim) the voltage at the base of Q1 is actually v_i , where in our analysis $v_i = v_{i-dm}/2$. E.g. the gain at Q1 output w.r.t v_i is:

$$A'_{v-dm2} = \frac{v_{c2-dm}}{v_i} = \frac{v_{c2-dm}}{v_{dm}/2} \approx \frac{R_C}{r_e + R_E}$$

Common Mode Analysis ($v_{i-dm} = 0$)

NOTE:

1. r_o for Q1 and Q2 are ignored.
2. Both R_B 's are ignored.

Balanced circuit

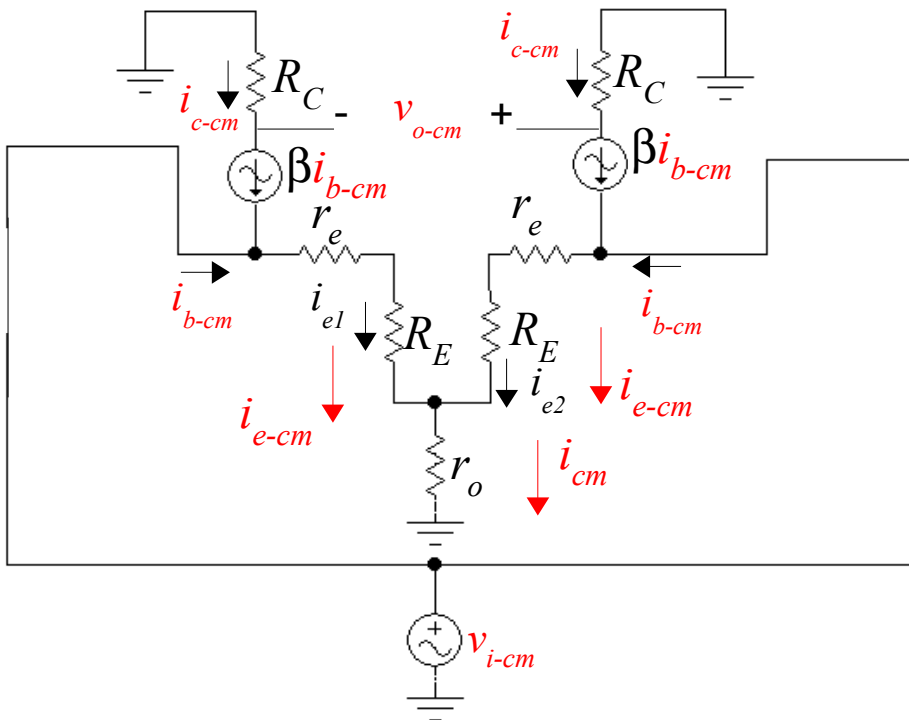

$$i_{cm} = i_{e-cm} + i_{e-cm} = 2i_{e-cm}$$

$$r_{in-cm} = (\beta + 1) \left(\frac{r_e + R_E}{2} + r_o \right) \approx (\beta + 1)r_o$$

Differential CM Voltage gain:

$$A_{v-cm} = \frac{v_{o-cm}}{v_{i-cm}} = 0$$

Single-Ended CM Voltage gains:

$$A_{v-cm1} = \frac{v_{c1-cm}}{v_{i-cm}} = -\frac{\beta R_C}{(\beta + 1)(r_e + R_E + 2r_o)} \approx -\frac{R_C}{2r_o}$$

$$A_{v-cm2} = \frac{v_{c2-cm}}{v_{i-cm}} = A_{v-cm1}$$

Common Mode Rejection Ratio

Common mode rejection ratio is the magnitude ratio of the differential mode gain over the common mode gain expressed in dB:

Differential:

$$A_{v-cm} = 0 \text{ (iff balanced)}$$

Single-Ended:

$$A_{v-cm2} = A_{v-cm1} \approx -\frac{R_C}{2r_o}$$

Differential:

$$A_{v-dm} \approx \frac{R_C}{r_e + R_E}$$

Single-Ended:

$$A_{v-dm2} = -A_{v-dm1} \approx \frac{R_C}{2(r_e + R_E)}$$

Differential:

(iff balanced)

$$CMRR = 20 \log_{10} \left(\frac{|A_{v-dm}|}{|A_{v-cm}|} \right) = \infty$$

Single-Ended:

$$CMRR = 20 \log_{10} \left(\frac{|A_{v-dm1,2}|}{|A_{v-cm1,2}|} \right)$$

$$CMRR \approx 20 \log_{10} \left(\frac{R_C}{2(r_e + R_E)} * \frac{2r_o}{R_C} \right)$$

$$CMRR \approx 20 \log_{10} \left(\frac{r_o}{r_e + R_E} \right)$$

What if the Diff Amp isn't Perfectly Balanced?

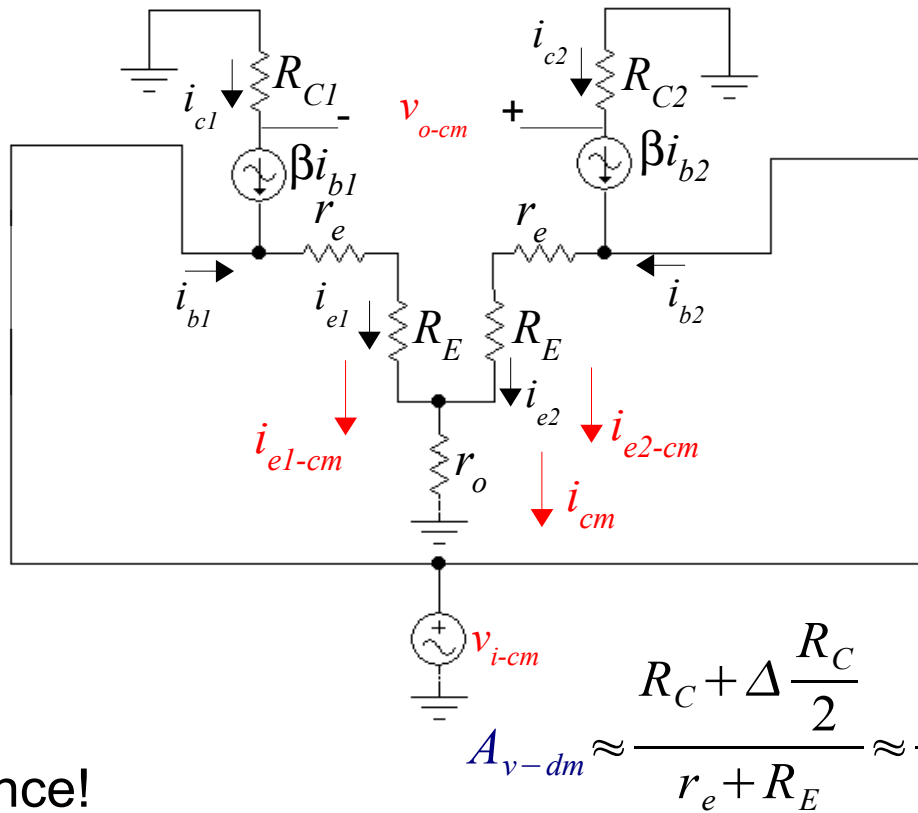

Let $R_{C2} > R_{C1}$, s.t. $R_{C1} = R_C$ and

$$R_{C2} = R_C + \Delta R_C \quad \text{where } \Delta R_C \ll R_C$$

$$A_{v-cm1} = \frac{v_{c1-cm}}{v_{i-cm}} \approx -\frac{R_C}{(r_e + R_E + 2r_o)} \approx -\frac{R_C}{2r_o}$$

$$A_{v-cm2} = \frac{v_{c2-cm}}{v_{i-cm}} \approx -\frac{R_C + \Delta R_C}{2r_o} = -\frac{R_C}{2r_o} \left(1 + \frac{\Delta R_C}{R_C}\right)$$

Hence!

$$A_{v-cm2} \neq A_{v-cm1} \approx -\frac{R_C}{2r_o} \quad \text{and} \quad A_{v-cm} \neq 0$$

$$CMRR = 20 \log_{10} \left(\left| \frac{A_{v-dm}}{A_{v-cm}} \right| \right) = 20 \log_{10} \left(\frac{2r_o}{r_e + R_E} \frac{1}{\Delta R_C / R_C} \right) \neq \infty$$

$$A_{v-cm} = A_{v-cm2} - A_{v-cm1} = -\frac{R_C}{2r_o} \frac{\Delta R_C}{R_C}$$



Summary

Differential mode (balanced)

$$r_{in-dm} = \frac{v_{i-dm}}{i_{b1-dm}} = (\beta + 1) 2(r_e + R_E)$$

$$A_{v-dm2} = \frac{v_{c2-dm}}{v_{i-dm}} = -A_{v-dm1} \approx \frac{R_C}{2(r_e + R_E)} \quad A_{v-dm} = \frac{v_{o-dm}}{v_{i-dm}} = \frac{R_C}{r_e + R_E}$$

Common mode (balanced)

$$r_{in-cm} = \frac{v_{i-cm}}{2i_{b-cm}} = (\beta + 1) \left(\frac{r_e + R_E}{2} + r_o \right)$$

$$A_{v-cm1} = \frac{v_{c1-cm}}{v_{i-cm}} = A_{v-cm2} \approx -\frac{R_C}{2r_o} \quad A_{v-cm} = \frac{v_{o-cm}}{v_{i-cm}} = 0 \quad \text{i.f.f. Balanced}$$

$$A_{v-cm} = \frac{v_{o-cm}}{v_{i-cm}} \approx \frac{R_C}{2r_o} \frac{\Delta R_C}{R_C} \quad \left\{ \begin{array}{l} \text{if Unbalanced due to} \\ R_{C1} \neq R_{C2} \end{array} \right.$$

Single-ended-output (balanced)

$$CMRR = \frac{A_{v-dm1,2}}{A_{v-cm1,2}} \approx 20 \log_{10} \left(\frac{r_o}{r_e + R_E} \right)$$

Differential-output

$$CMRR = \infty \quad \text{i.f.f. Balanced}$$

$$CMRR = 20 \log_{10} \left(2 \frac{r_o}{r_e + R_E} \frac{1}{\Delta R_C / R_C} \right)$$