

Device	$V_{gs}$	$I_d$
NMOS	$V_{gs} < V_{thn}$	$(3 \times 10^{-7}) e^{\frac{V_{gs}-V_{thn}}{40mV}}$
	$V_{gs} > V_{thn}$	$1.8 \times 10^{-4} (V_{gs} - V_{thn})$
PMOS	$V_{gs} > V_{thp}$	$(3 \times 10^{-7}) e^{-\left(\frac{V_{gs}-V_{thp}}{40mV}\right)}$
	$V_{gs} < V_{thp}$	$-1.8 \times 10^{-4} (V_{gs} - V_{thp})$

Consider an inverter using the pmos and nmos devices described above:

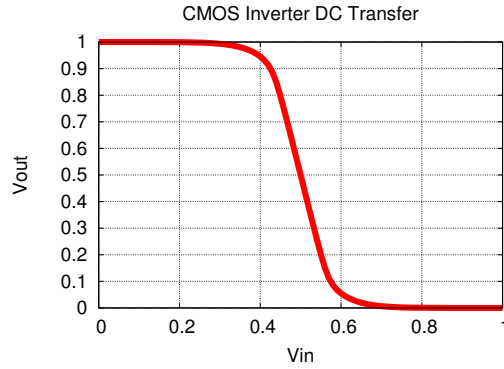
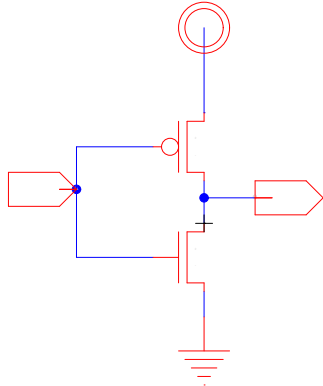

Useful:  $e^{-1} \approx 0.37$ ,  $e^{-4} \approx 0.02$ ,  $e^{-7.5} \approx 6 \times 10^{-4}$ ,

- $V_{dd}=1V$ ,  $V_{thn}=300mV$ ,  $V_{thp}=-300mV$ , assume the static current is in steady-state operation and dynamic/short circuit current are the peak currents at  $V_{in}$  given.

$V_{in}$	$I_{static}$	$I_{dynamic}$	$I_{sc}$	
0V				A
140mV				B
400mV				C
500mV				D
600mV				E
860mV				F
1V				G

2.  $V_{dd}=520\text{mV}$ ,  $V_{thn}=300\text{mV}$ ,  $V_{thp}=-300\text{mV}$ , assume gate is unloaded (no output capacitance to charge).

$V_{in}$	$I_{static}$	$I_{dynamic}$	$I_{sc}$	
0V				A, F
140mV				B, G
260mV				C
380mV				D
520mV				E

3.  $V_{thn}=300\text{mV}$ ,  $V_{thp}=-300\text{mV}$ ,  $V_{in}=V_{dd}$ ; estimate  $\tau = CV/I$

$V_{dd}$	$I_{dyn}$	$\frac{\tau}{\tau(V_{dd}=1V)}$	$\frac{E_{switch}}{E_{switch}(V_{dd}=1V)}$	$E\tau$	
1V		1	1	1	all
700mV					A, E
500mV					B, F
350mV					C, G
260mV					D

4.  $V_{dd}=1V$ ,  $V_{in}=V_{dd}$

$V_{thn} = -V_{thp}$	$I_{dyn}$	$\frac{\tau}{\tau( V_{th} =300\text{mV})}$	$I_{static}$	$\frac{I_{static}}{I_{static}( V_{th} =300\text{mV})}$	
300mV		1		1	all
460mV					A, B, C
600mV					D, E, F, G

Device	$V_{gs}$	$I_d$
NMOS	$V_{gs} < V_{thn}$	$(3 \times 10^{-7}) e^{\frac{V_{gs}-V_{thn}}{40\text{mV}}}$
	$V_{gs} > V_{thn}$	$1.8 \times 10^{-4} (V_{gs} - V_{thn})$
PMOS	$V_{gs} > V_{thp}$	$(3 \times 10^{-7}) e^{-\left(\frac{V_{gs}-V_{thp}}{40\text{mV}}\right)}$
	$V_{gs} < V_{thp}$	$-1.8 \times 10^{-4} (V_{gs} - V_{thp})$