

ESE370: Circuit-Level Modeling, Design, and Optimization for Digital Systems

Lec 4: January 30, 2023
Regenerative Property





Today

- We know how to make our logic functional, but how do we make sure logic is robust?
 - To enable design cascading gates into any (feed forward) graph and still tolerate voltage drops and noise, while maintaining digital abstraction



Outline

- Two signal problems → Gate Cascade failure
- Regeneration Solution → Gate Abstraction
 - Transfer Curves
 - Noise Margins
 - Non-linearity



Two Signal Problems

1. Output does not go to rail
Stops short of V_{dd} or Gnd
2. Signals may be perturbed by noise

$$V_x = V_{\text{ideal}} \pm V_{\text{noise}}$$

Wire Resistance (Pg 2 preclass)

□ Resistance of 100 μm long wire?

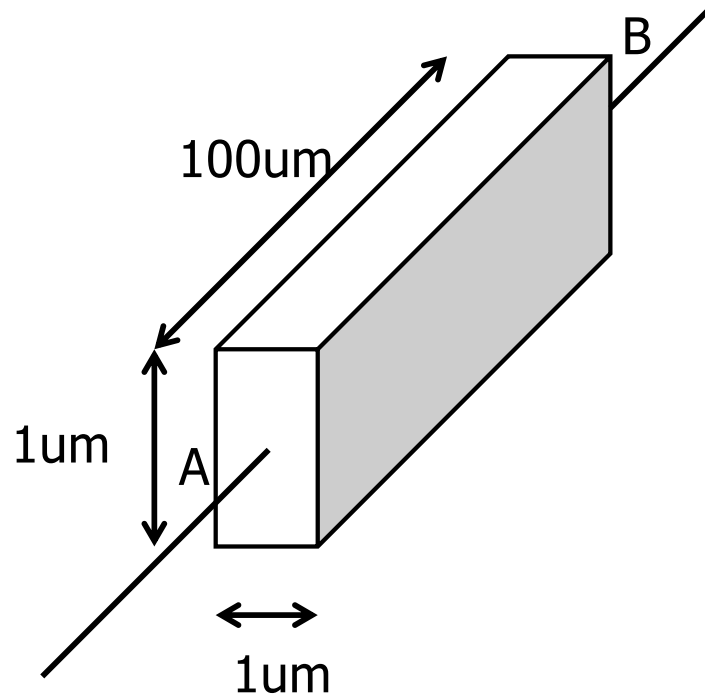

$$\rho = 10^{-7} \Omega \cdot \text{m}$$

$$R = \frac{\rho L}{A}$$

Wire Resistance

□ 100 μm long wire?

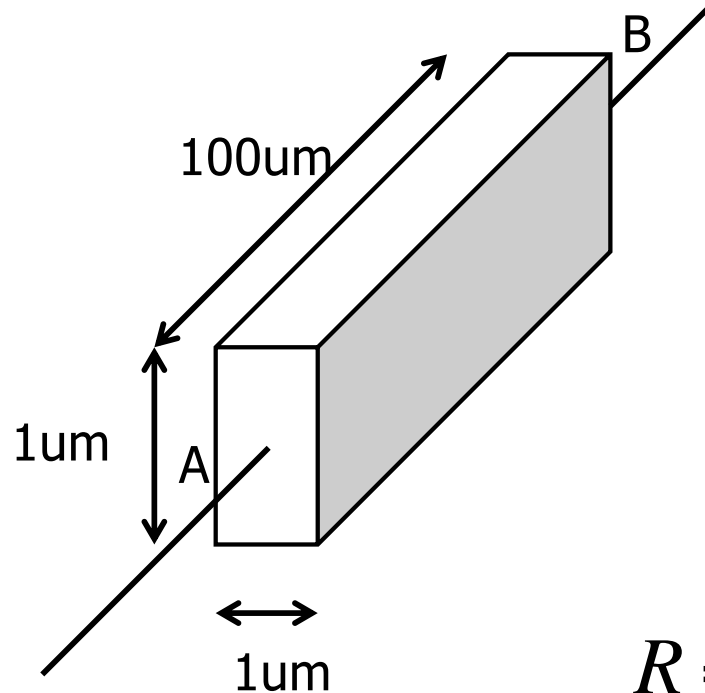

$$R = \frac{\rho L}{A}$$

$$R = \frac{10^{-7} \Omega \cdot m \cdot 100 \mu m}{1 \mu m \cdot 1 \mu m} = 10 \Omega$$



Wire Resistance

- ❑ 1 mm long wire?
- ❑ 1 cm long wire?
- ❑ Length of integrated circuit chip side?
 - (we often call an IC chip a “die”)



Die Sizes

Chip	#Trans.	Year	Maker	process	mm ²
GK10 Kepler	7B	2012	NVIDIA	28nm	561
22-core Xeon Broadwell-E5	7B	2016	Intel	14nm	456
GC2 IPU	23.6B	2018	Graphcore	16nm	825
Apple A12X Bionic	10B	2018	Apple	7nm	122
Tegra Xavier SoC	9B	2018	Nvidia	12nm	350
Navi 10	10B	2021	AMD	7nm	251

source: http://en.wikipedia.org/wiki/Transistor_count

Implications

- ❑ What does the circuit really look like for an inverter in the middle of the chip?

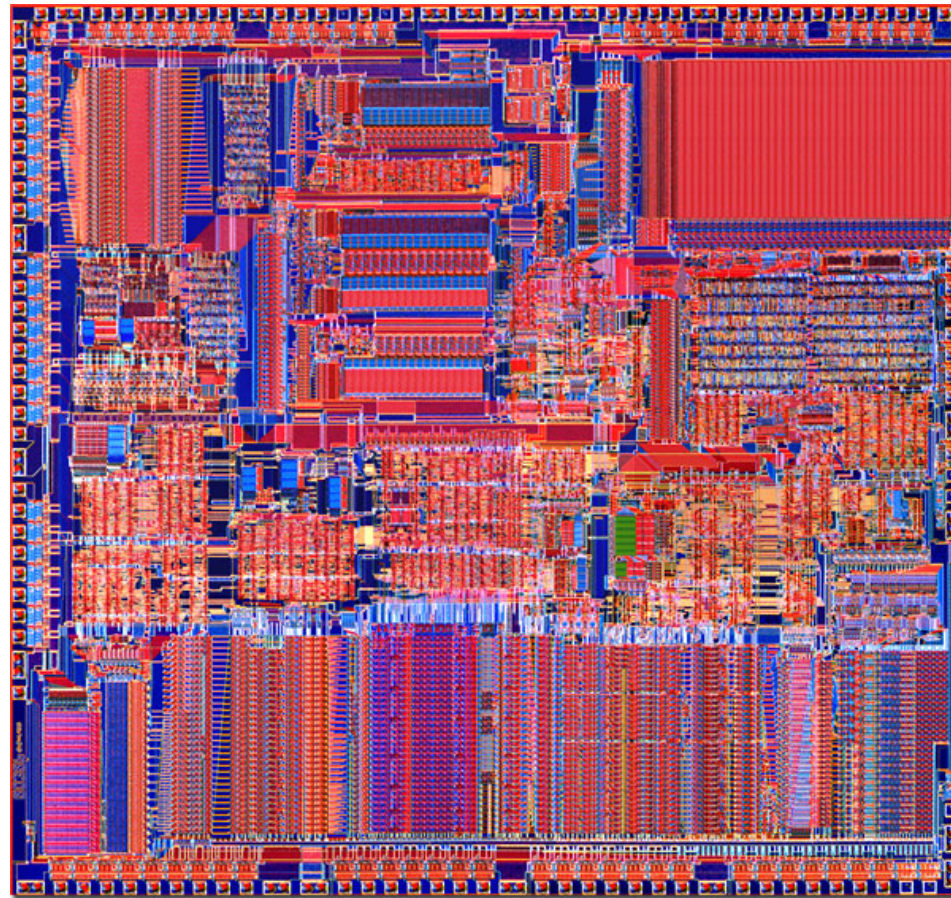



Implications

- What does the circuit really look like for an inverter in the middle of the chip?

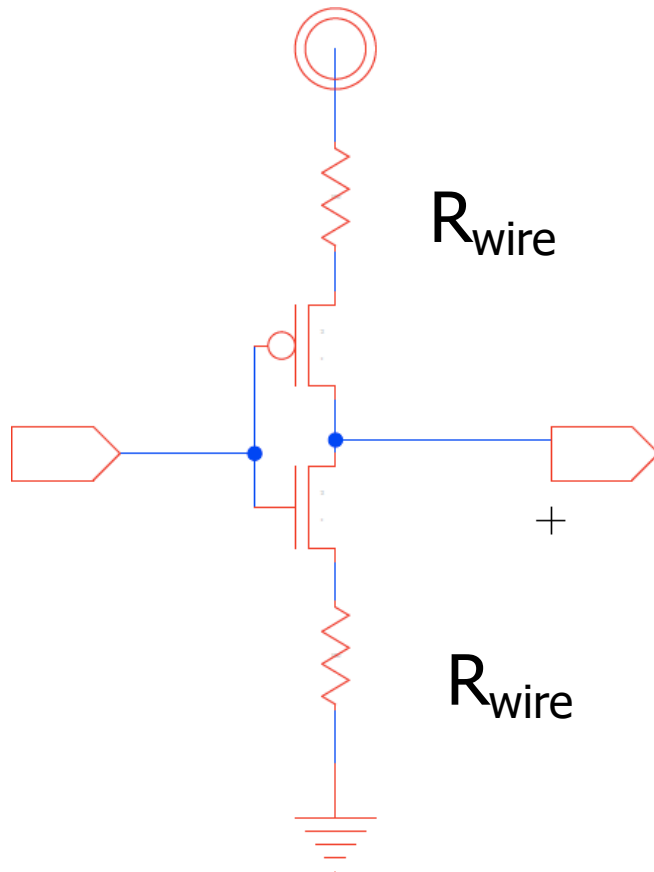



Implications

- What does the circuit really look like for an inverter in the middle of the chip?

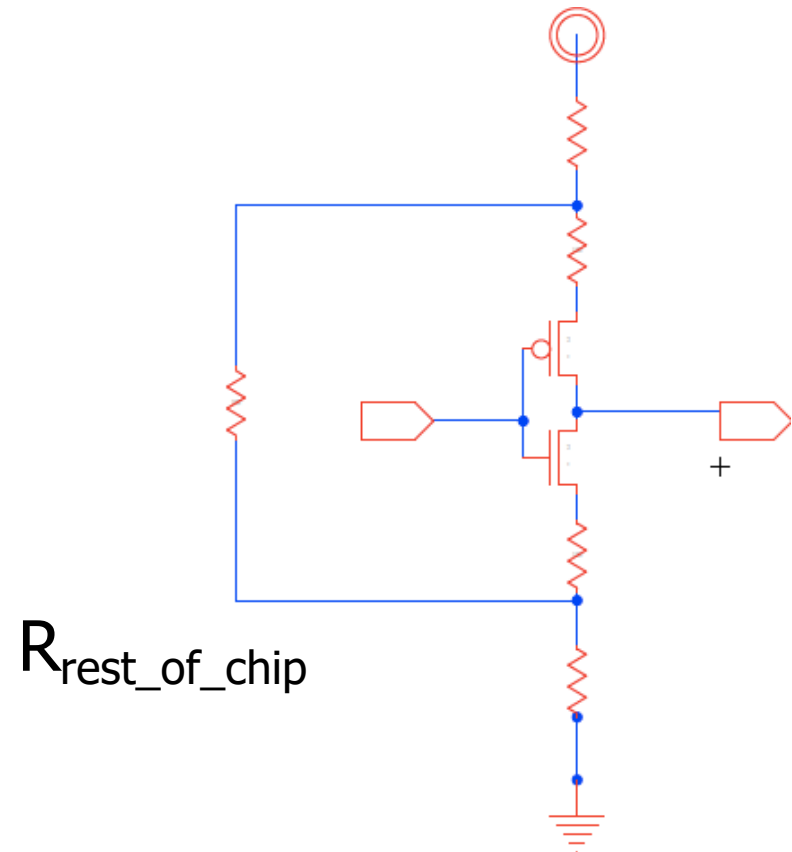
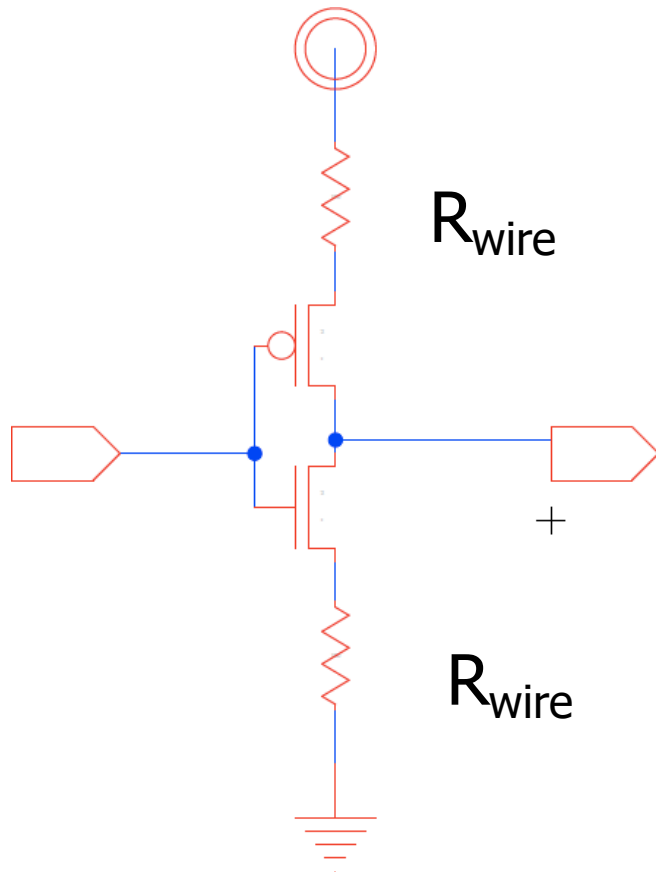

IR-Drop

- Since interconnect is resistive and gates pull current off the supply interconnect
 - The V_{dd} seen by a gate is lower than the supply Voltage by
 - $V_{drop} = I_{supply} \times R_{distributed}$
 - Two gates in different locations
 - See different $R_{distributed}$
 - Therefore, see different V_{drop}

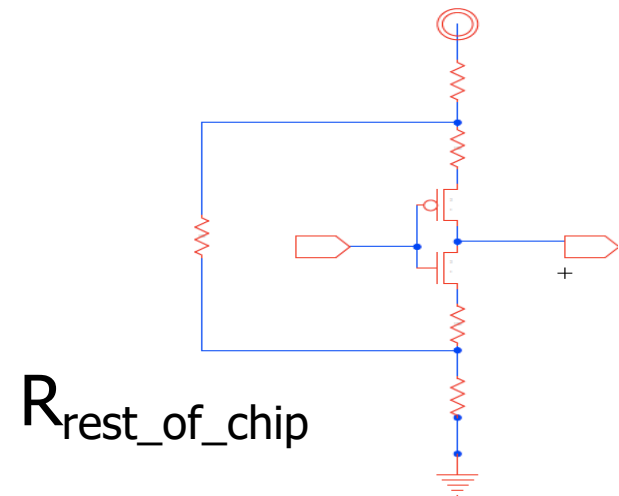

Output does not go to Rail

- Due to V_{drop} , “rails” for two communicating gates may not match

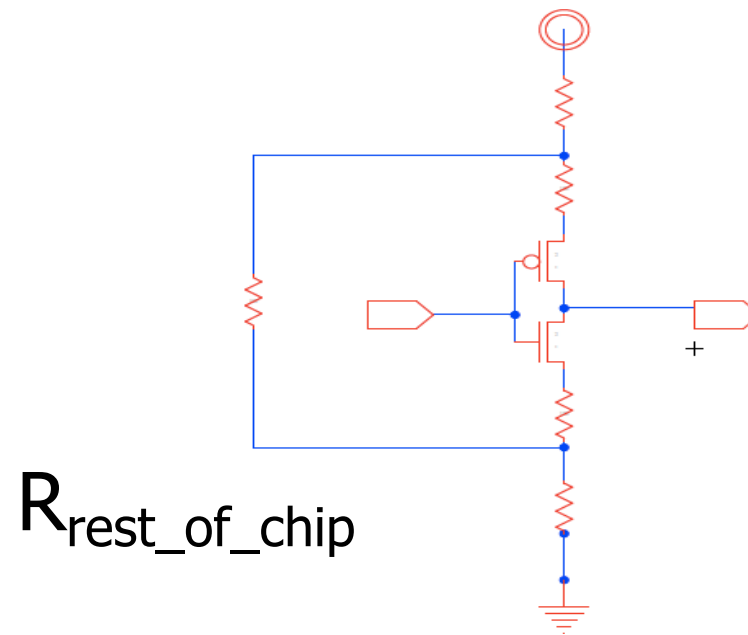



Two Signal Problems

1. Output not go to rail
Different swing for gates
2. Signals may be perturbed by noise
Voltage seen at input to a gate may be lower/higher than input voltage



Noise Sources?

- ❑ Signal coupling (will be covered in later lecture)
 - Crosstalk
- ❑ Inductive noise
- ❑ Leakage (will be covered in later lecture)
- ❑ Ionizing particles (shot noise)



Signals **will** be degraded

1. Output not go to rail
 - Is this tolerable?
 2. Signals may be perturbed by noise
 - Voltage seen at input to a gate may be lower/higher than expected input voltage
- What happens to degraded signals?



Preclass Pg 1 preclass

- What is the output when all inputs are all 1s?

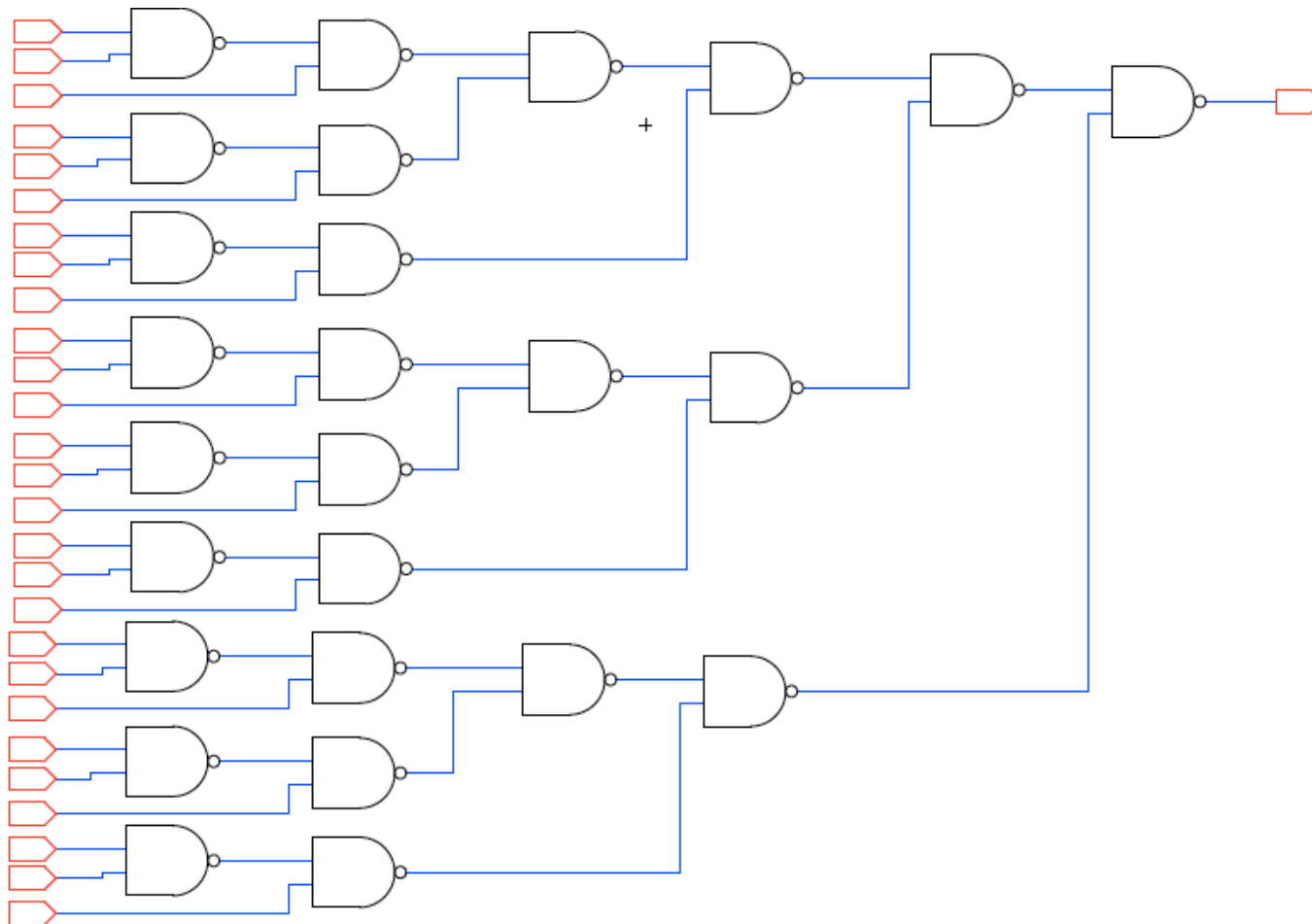



Preclass Pg 1

- What is the output when all inputs are all 1s?

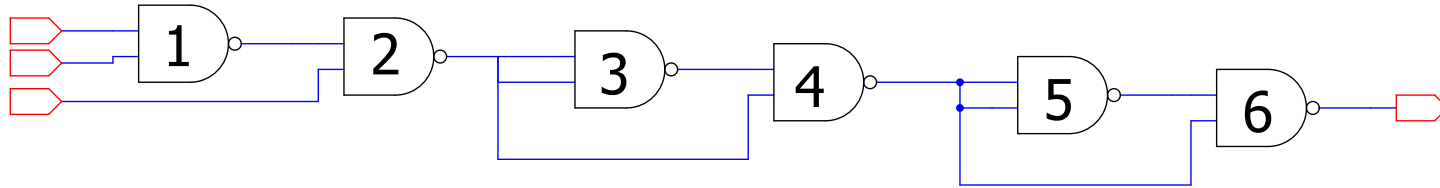



Preclass Pg 1

- What is the output when all inputs are all 1.0 and $\text{NAND}(A, B) = 1 - A * B$?

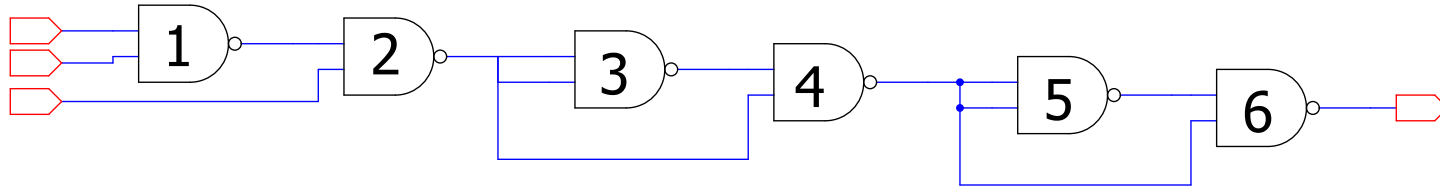



Preclass Pg 1

- What is the output when all inputs are all 0.95 and $\text{NAND}(A, B) = 1 - A * B$?

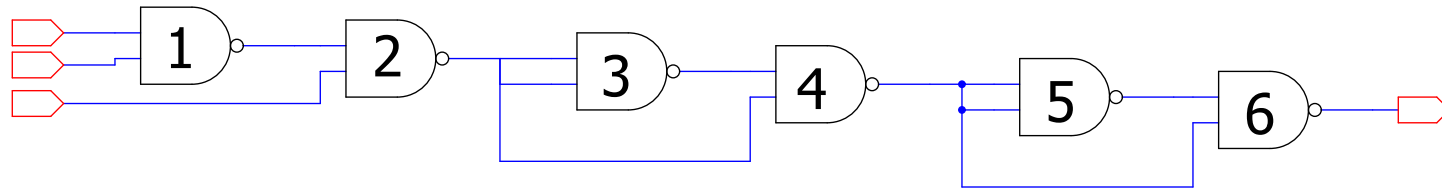



Degradation

- ❑ Cannot have signal degrade across cascaded gates
- ❑ Want to be able to cascade arbitrary set of gates
 - No limit on number of gates to maintain signal integrity



Gate Creed

- Gates should leave the signal “better” than they found it
 - “better” → closer to the rails



Regeneration Discipline

- Define legal inputs
 - Gate works if V_{in} “close enough” to the rail



Regeneration Discipline

- Define legal inputs
 - Gate works if V_{in} “close enough” to the rail

- Regeneration
 - Gate produces V_{out} “closer to rail”
 - This tolerates some drop between one gate and next (between out and in)
 - Call this our “Noise Margin”

Regeneration/Restoration/Static Discipline

Noise Margin

- V_{OH} – output high
- V_{OL} – output low

- V_{IH} – input high
- V_{IL} – input low

- $NM_H = V_{OH} - V_{IH}$
- $NM_L = V_{IL} - V_{OL}$

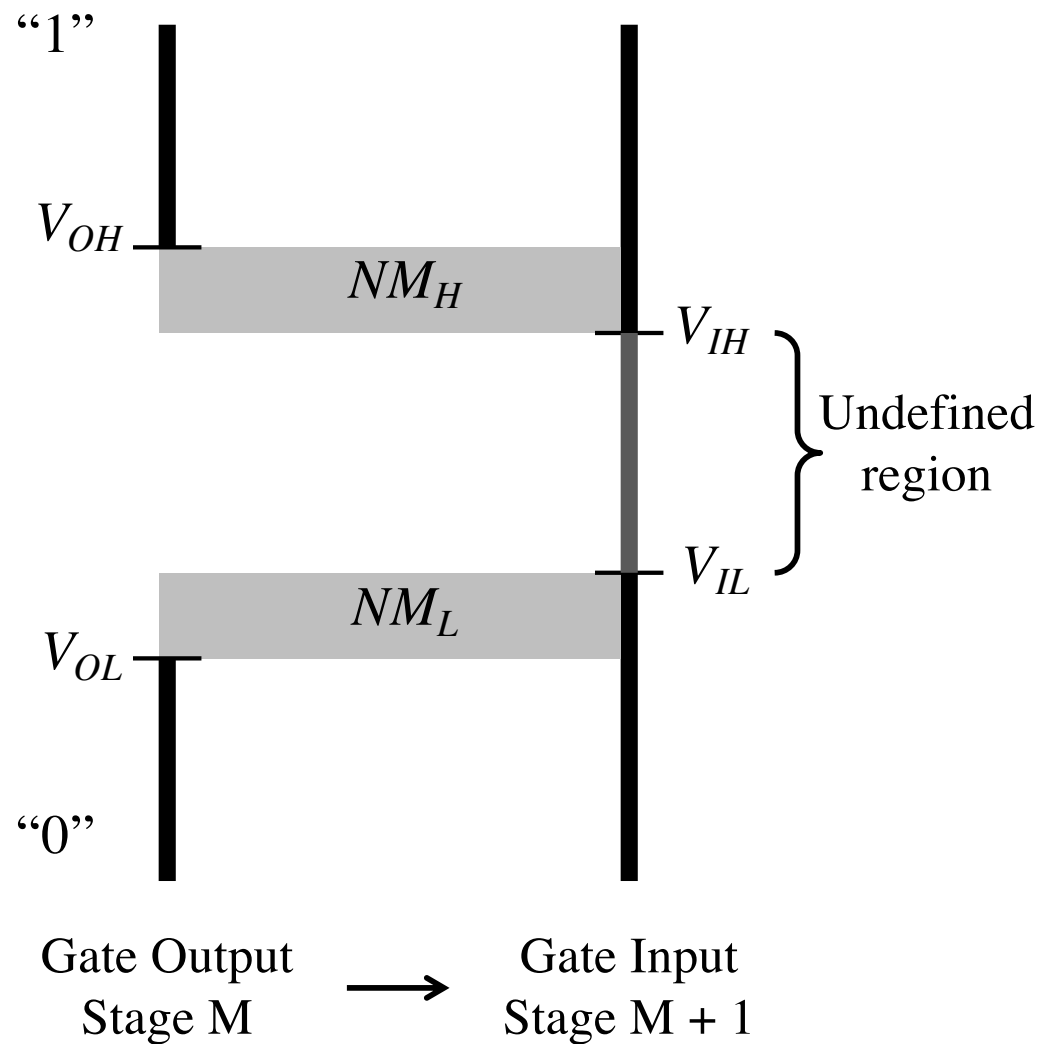

Regeneration Discipline (getting precise)

□ Define legal inputs

- Gate works if V_{in} “close enough” to the rail
- $V_{in} > V_{IH}$ or $V_{in} < V_{IL}$

□ Regeneration

- Gate produces V_{out} “closer to rail”
 - $V_{out} < V_{OL}$ or $V_{out} > V_{OH}$

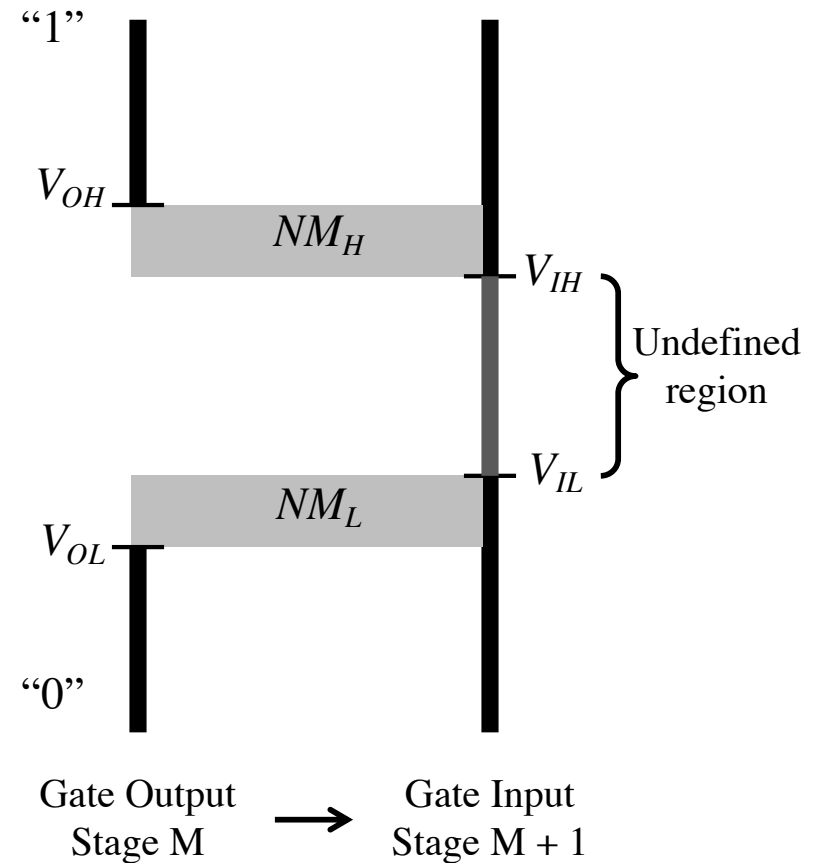



Transfer Function

- Describes what the output is given logic gate input
 - $V_{\text{out}} = f(V_{\text{in}})$



Transfer Function

- What gate is this?

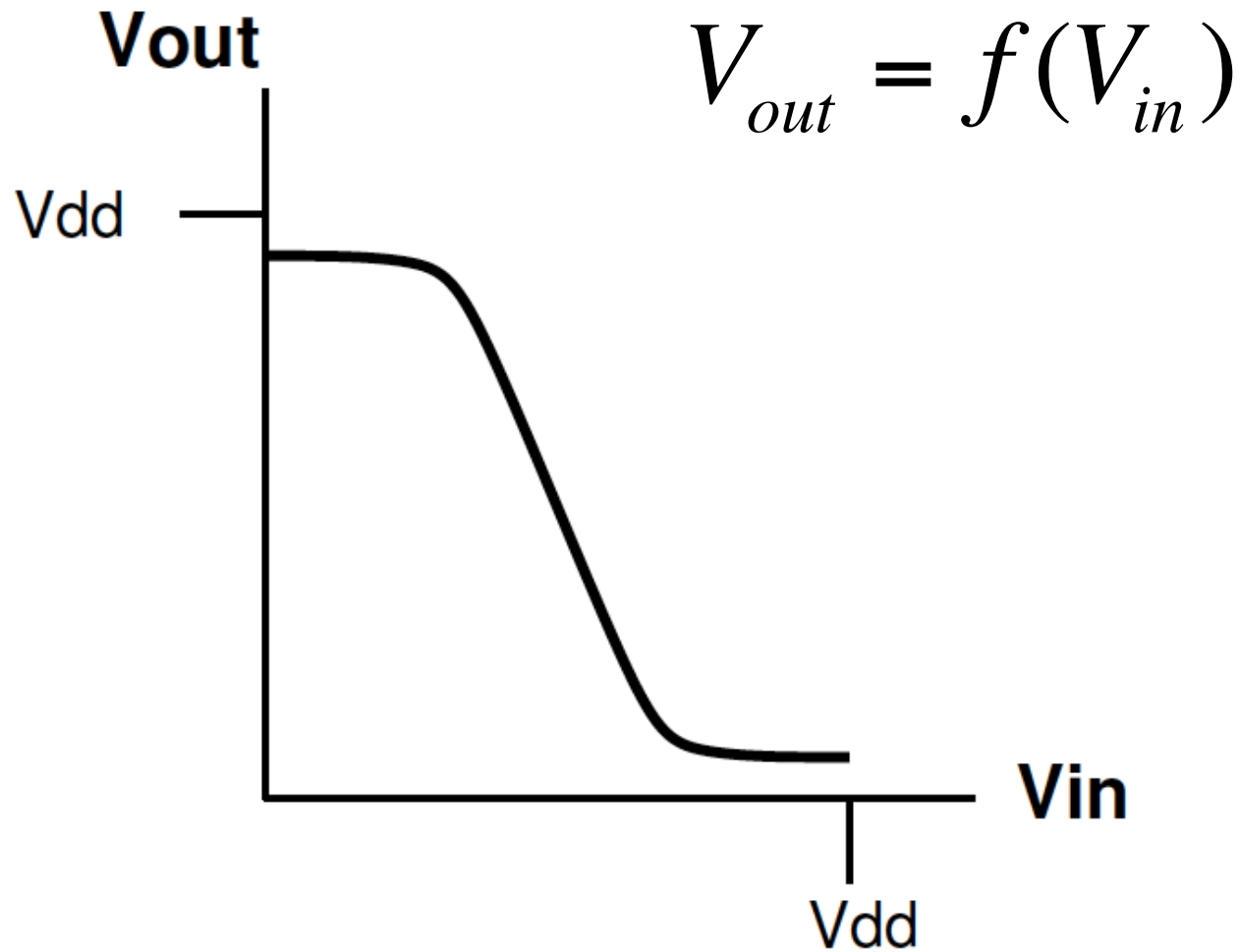

Transfer Function

- What gate is this?

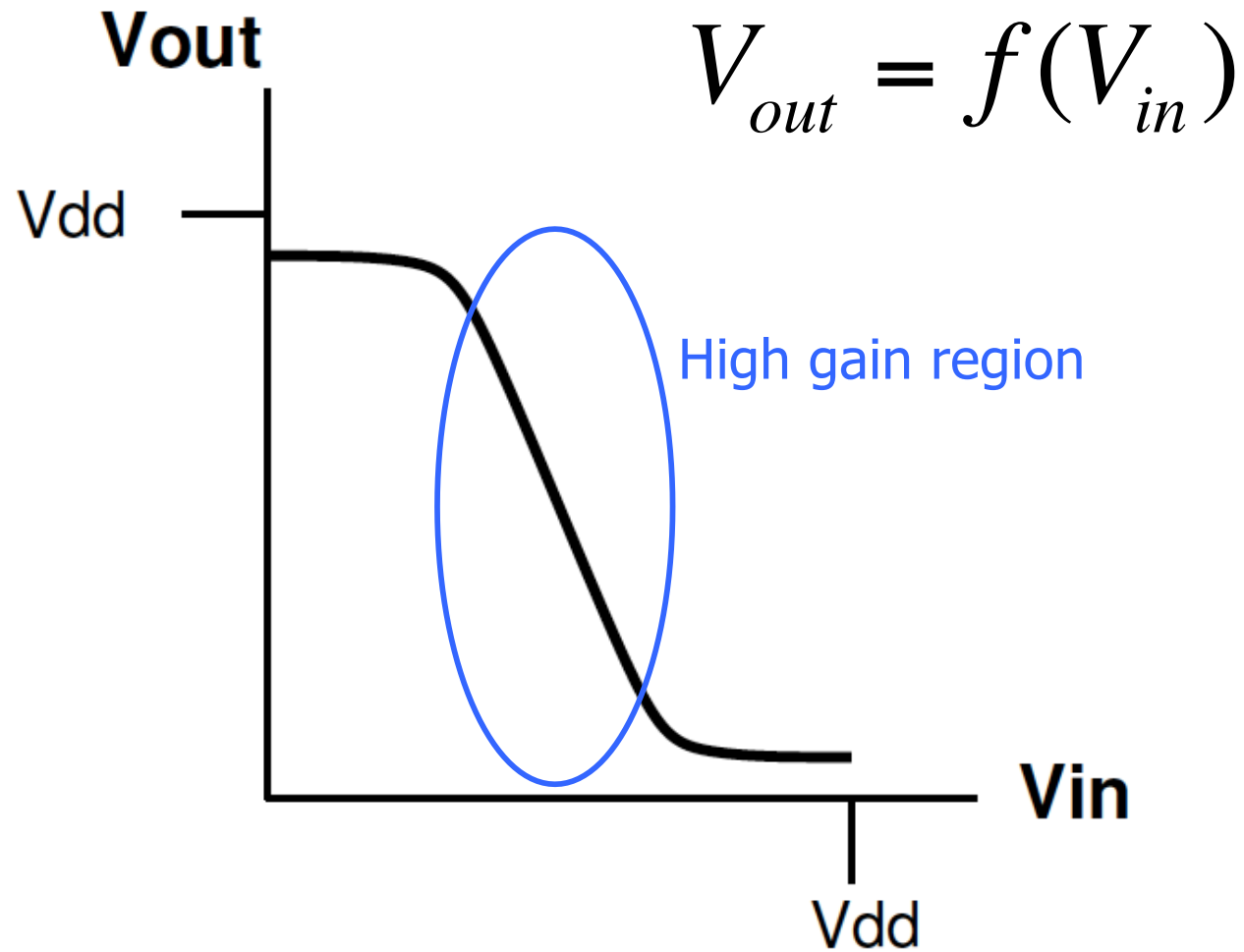

Regenerating Transfer Function

- Use gain (i.e. slope) to define noise margins

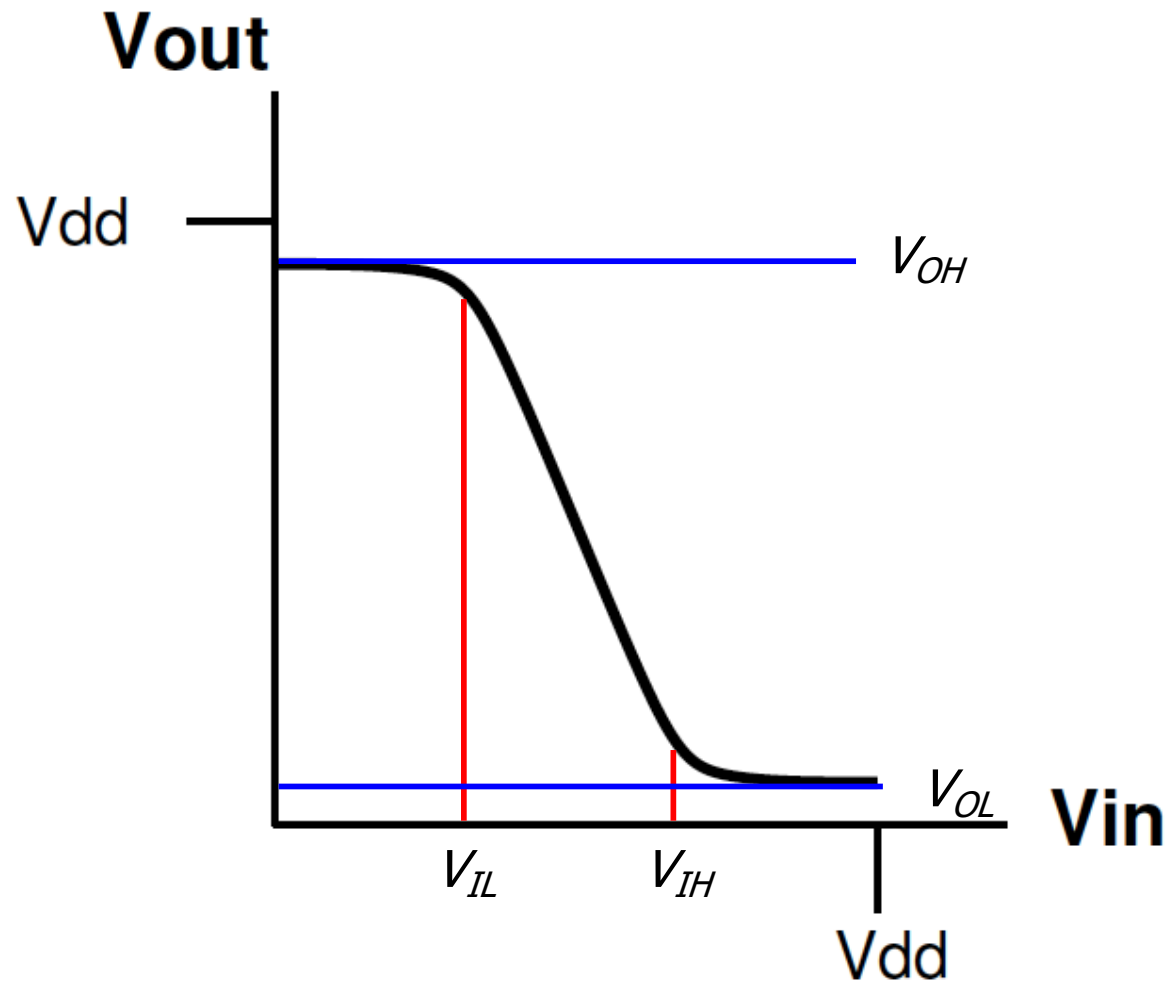

Regenerating Transfer Function

- Use gain (i.e. slope) to define noise margins

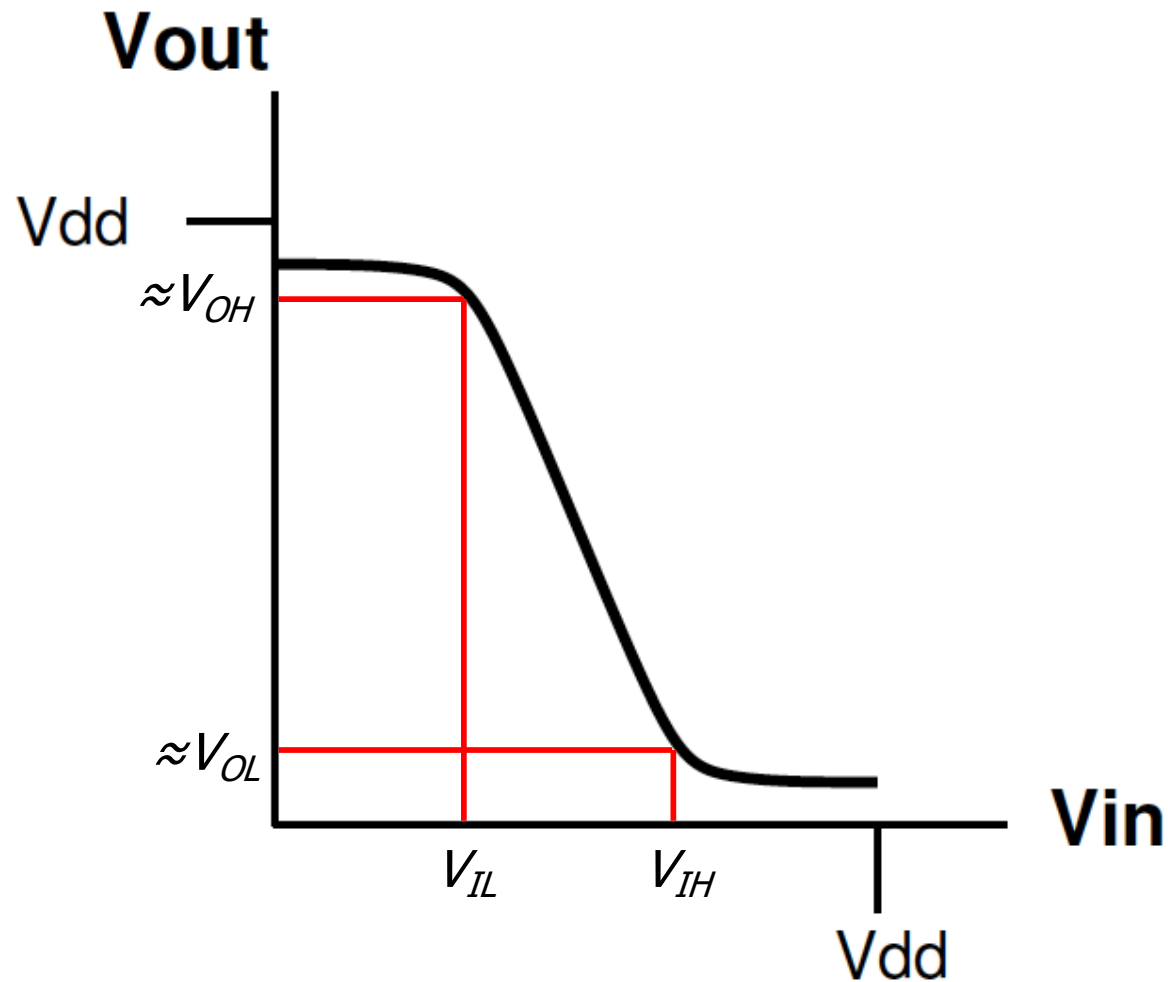

Regenerating Transfer Function

- Use gain (i.e. slope) to define noise margins

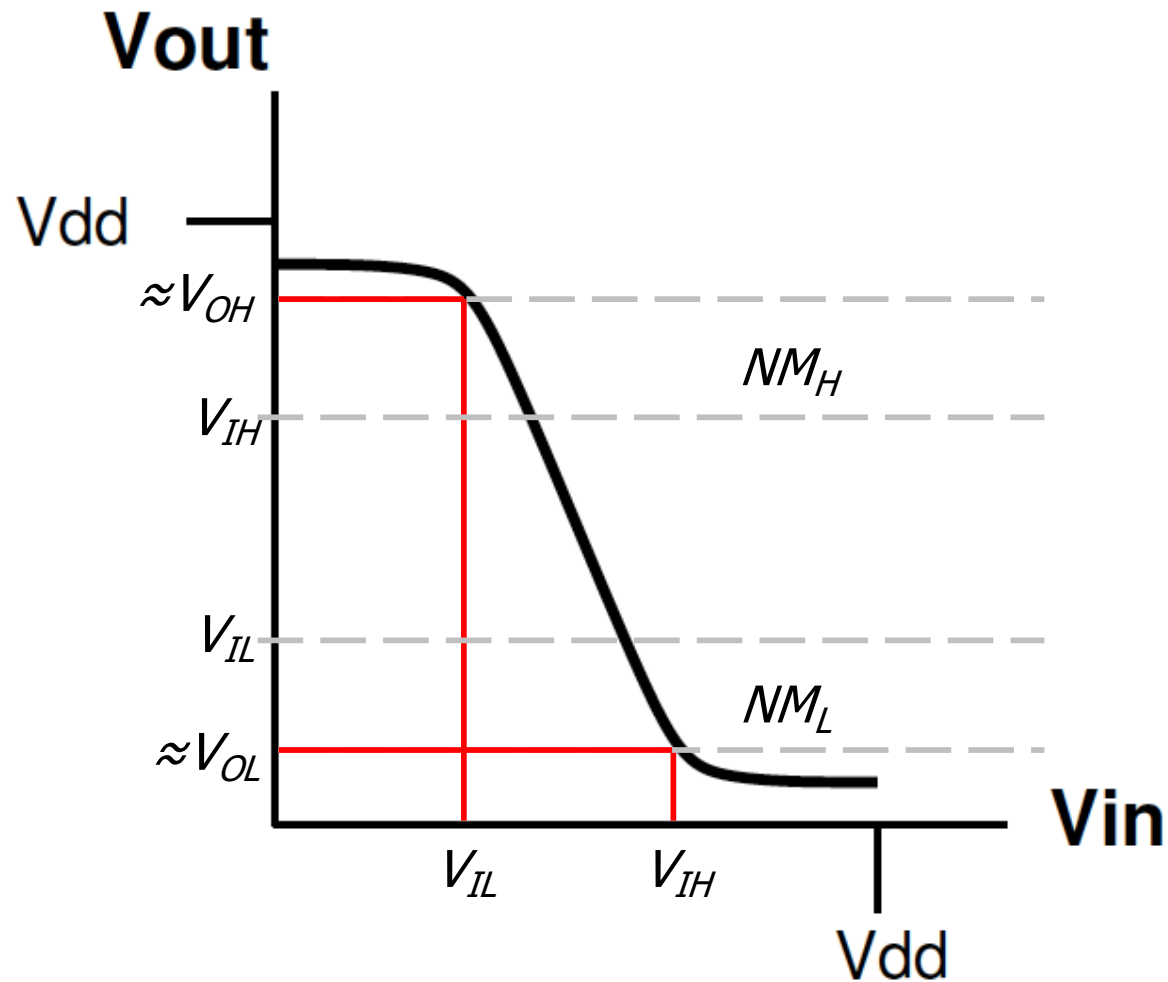

Decomposing

- What is gain?
 - $|\Delta V_{out}/\Delta V_{in}|$

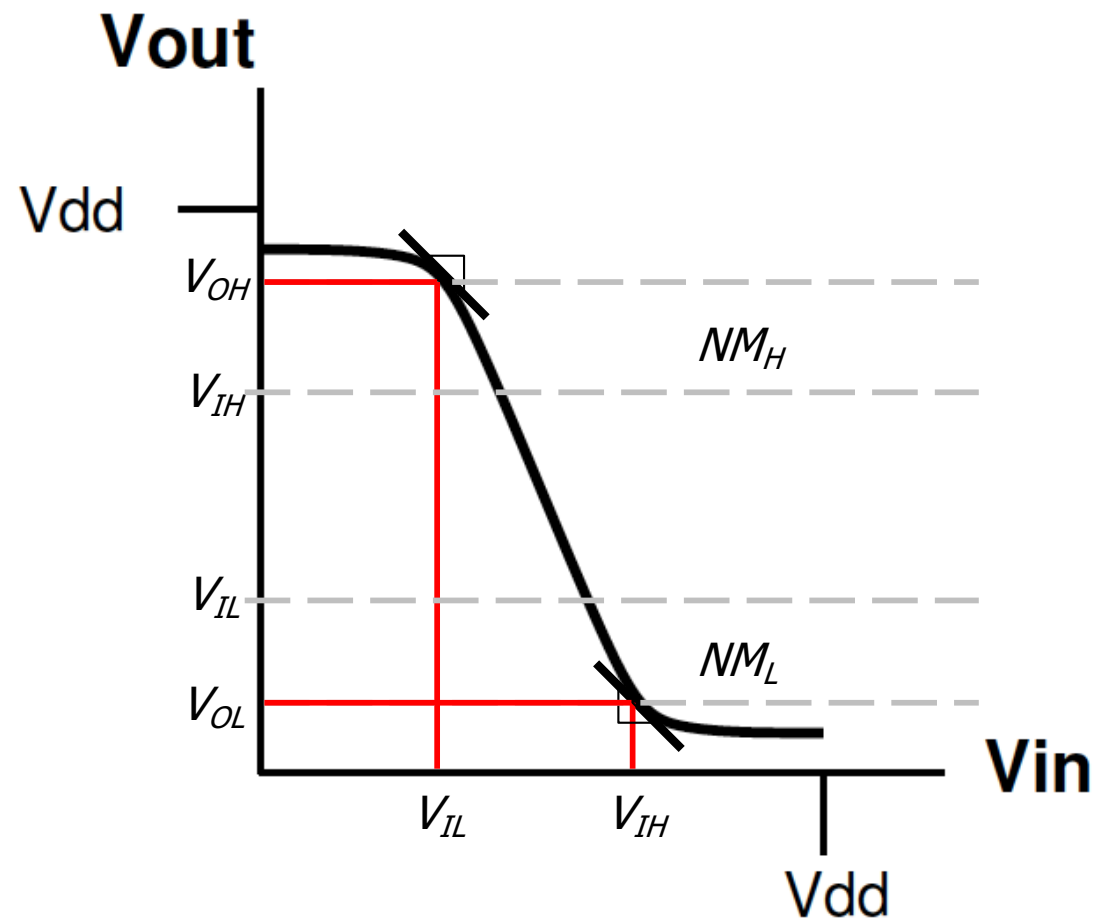



Decomposing

- What is gain?
 - $|\Delta V_{out}/\Delta V_{in}|$
- Where is there high gain?
 - $|\Delta V_{out}/\Delta V_{in}| > 1$

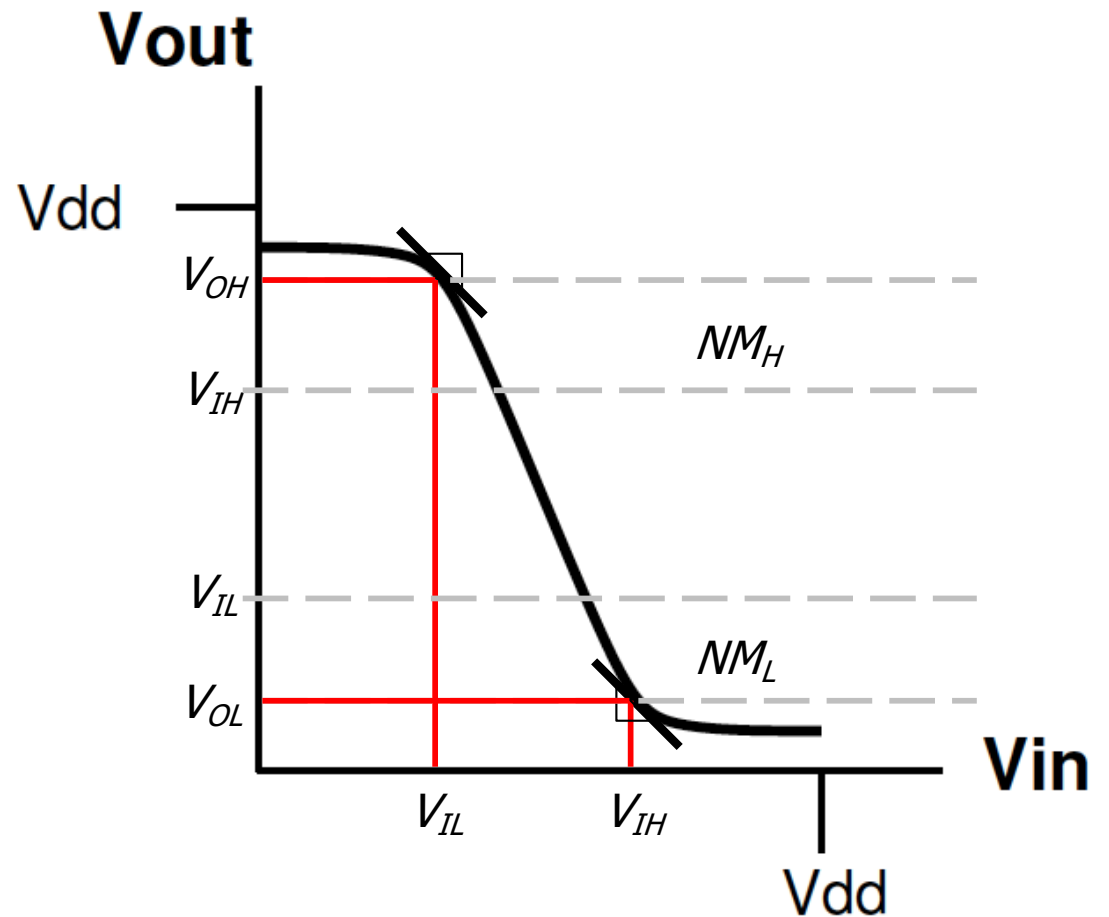

Decomposing

- What is gain?
 - $|\Delta V_{out}/\Delta V_{in}|$
- Where is there high gain?
 - $|\Delta V_{out}/\Delta V_{in}| > 1$
- Where is there low gain?
 - $|\Delta V_{out}/\Delta V_{in}| < 1$

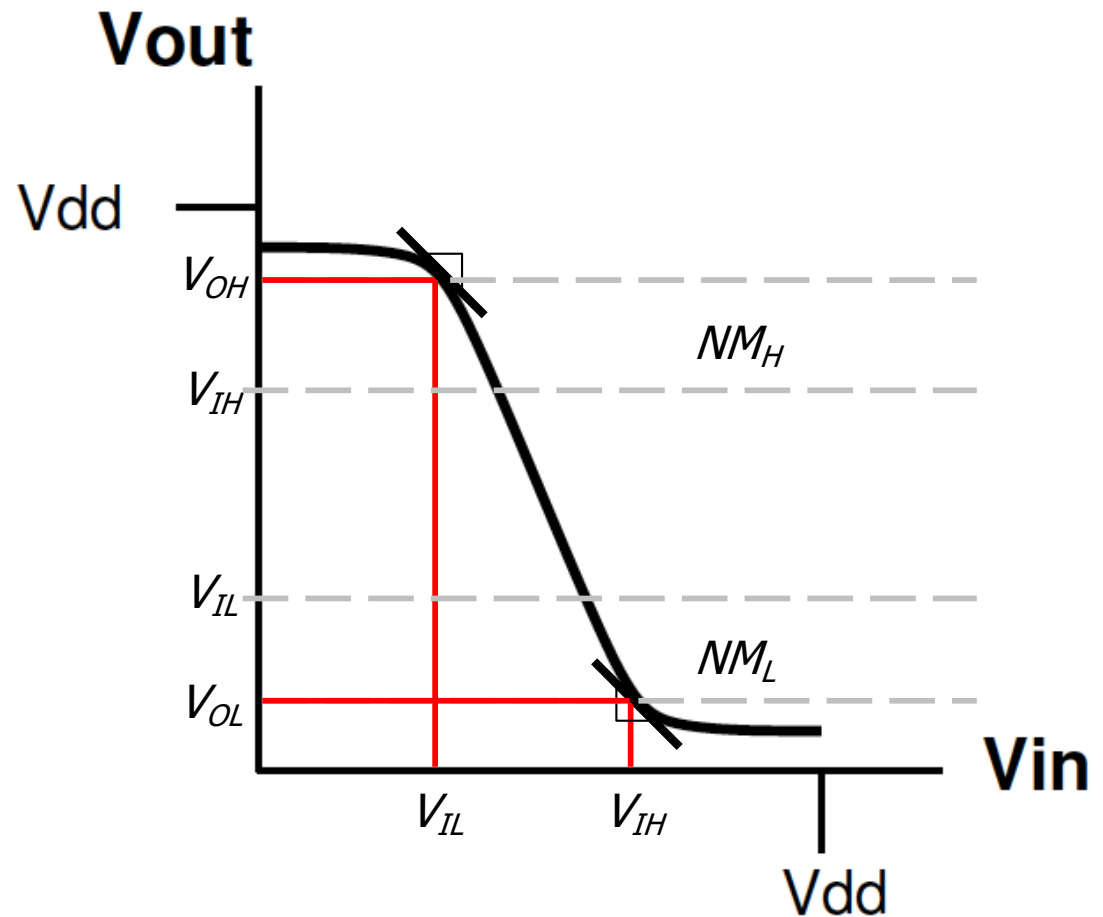

Decomposing

- What is gain?
 - $|\Delta V_{out}/\Delta V_{in}|$
- Where is there high gain?
 - $|\Delta V_{out}/\Delta V_{in}| > 1$
- Where is there low gain?
 - $|\Delta V_{out}/\Delta V_{in}| < 1$
- Dividing point?

$$\left. \frac{\delta V_{out}}{\delta V_{in}} \right|_{V_{IL}} = \left. \frac{\delta V_{out}}{\delta V_{in}} \right|_{V_{IH}} = -1$$

$$V_{OH} = f(V_{IL})$$

$$V_{OL} = f(V_{IH})$$

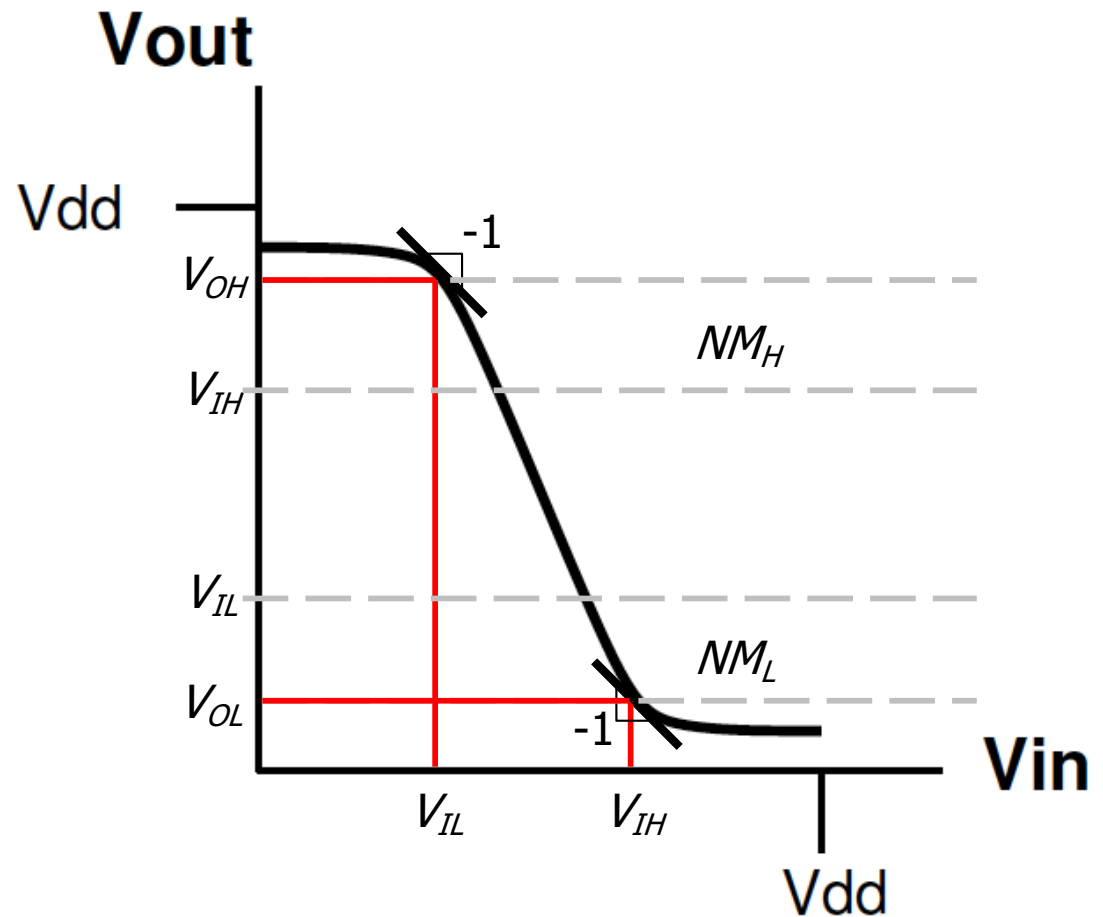

Decomposing

- An input closer to rail than V_{IL} , V_{IH} doesn't make much difference on V_{out}
 - i.e transfer function is flat for input close to rails
- Defining V_{IL} lower (or V_{IH} higher) would reduce NMs and increase our undefined region

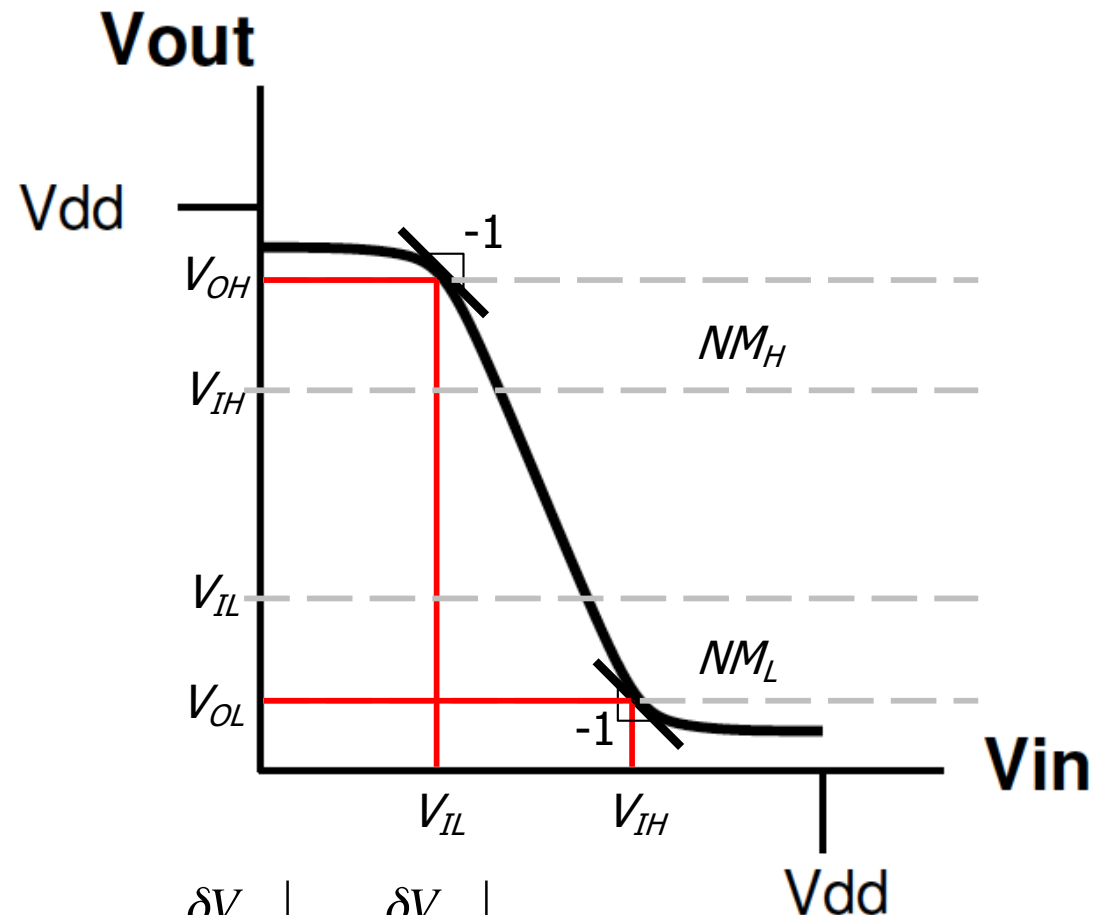

$$\left. \frac{\delta V_{out}}{\delta V_{in}} \right|_{V_{IL}} = \left. \frac{\delta V_{out}}{\delta V_{in}} \right|_{V_{IH}} = -1$$

$$V_{OH} = f(V_{IL})$$

$$V_{OL} = f(V_{IH})$$

Transfer Function for Multiple Inputs

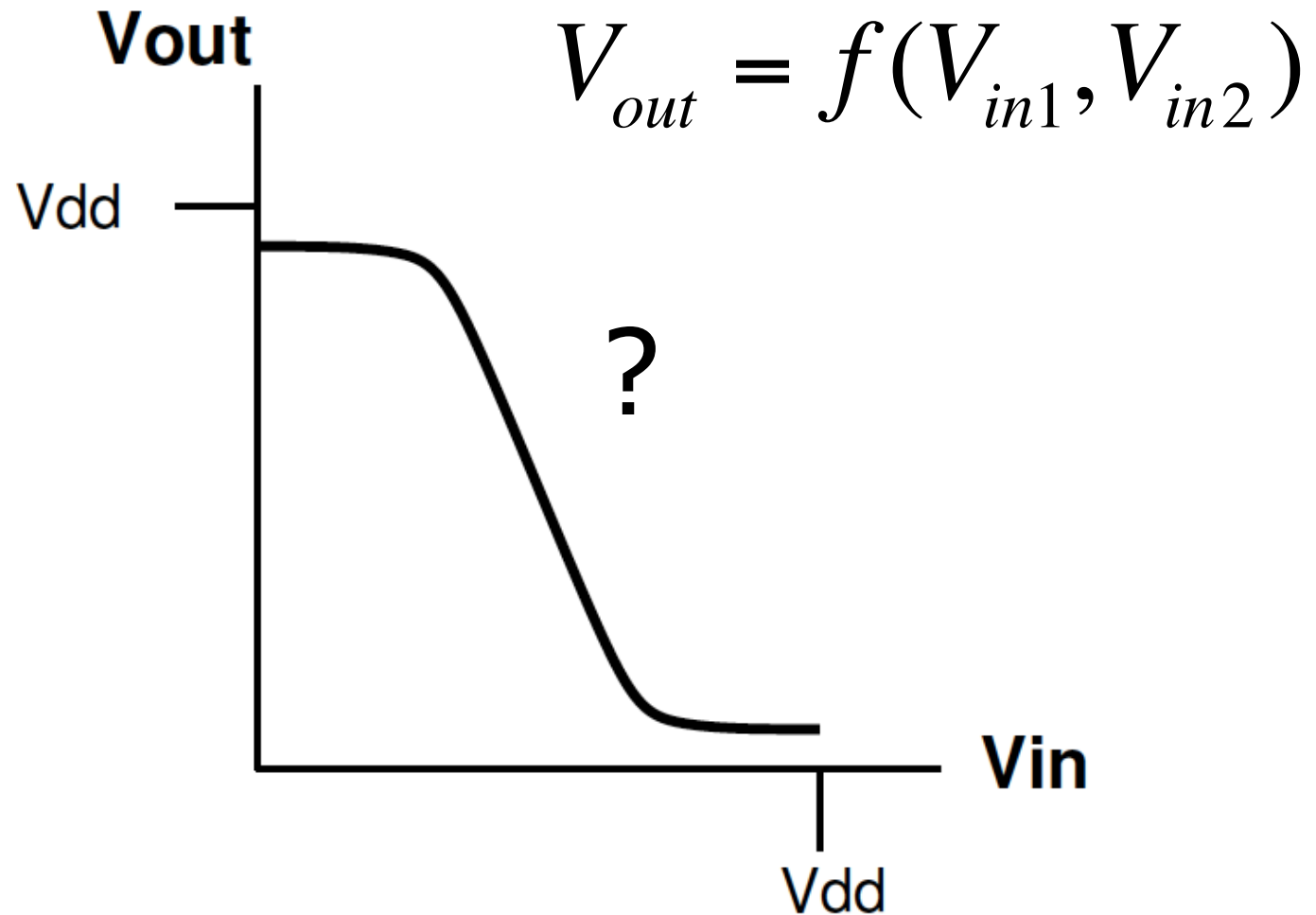



Controlling Input

- Consider a nand2 gate
 - If want A to control the output
 - What value should B be?
- We call B the **non-controlling** input since it does not determine the output



Controlling Input

- Consider a nand2 gate
 - If want A to control the output
 - What value should B be?
- We call B the **non-controlling** input since it does not determine the output

A	B	NAND
0	0	1
0	1	1
1	0	1
1	1	0

Controlling Input

- Consider a nand2 gate
 - If want A to control the output
 - What value should B be?
- We call B the **non-controlling** input since it does not determine the output
- What should the non-controlling input value be for a nor2 gate?

A	B	NOR	A	B	NAND
0	0	1	0	0	1
0	1	0	0	1	1
1	0	0	1	0	1
1	1	0	1	1	0



Controlling Input for Worst Case

- Consider a nor2/nand2 gate
 - If want A to control the output
 - What value should B be?

Ideal Transfer Function for Inverter

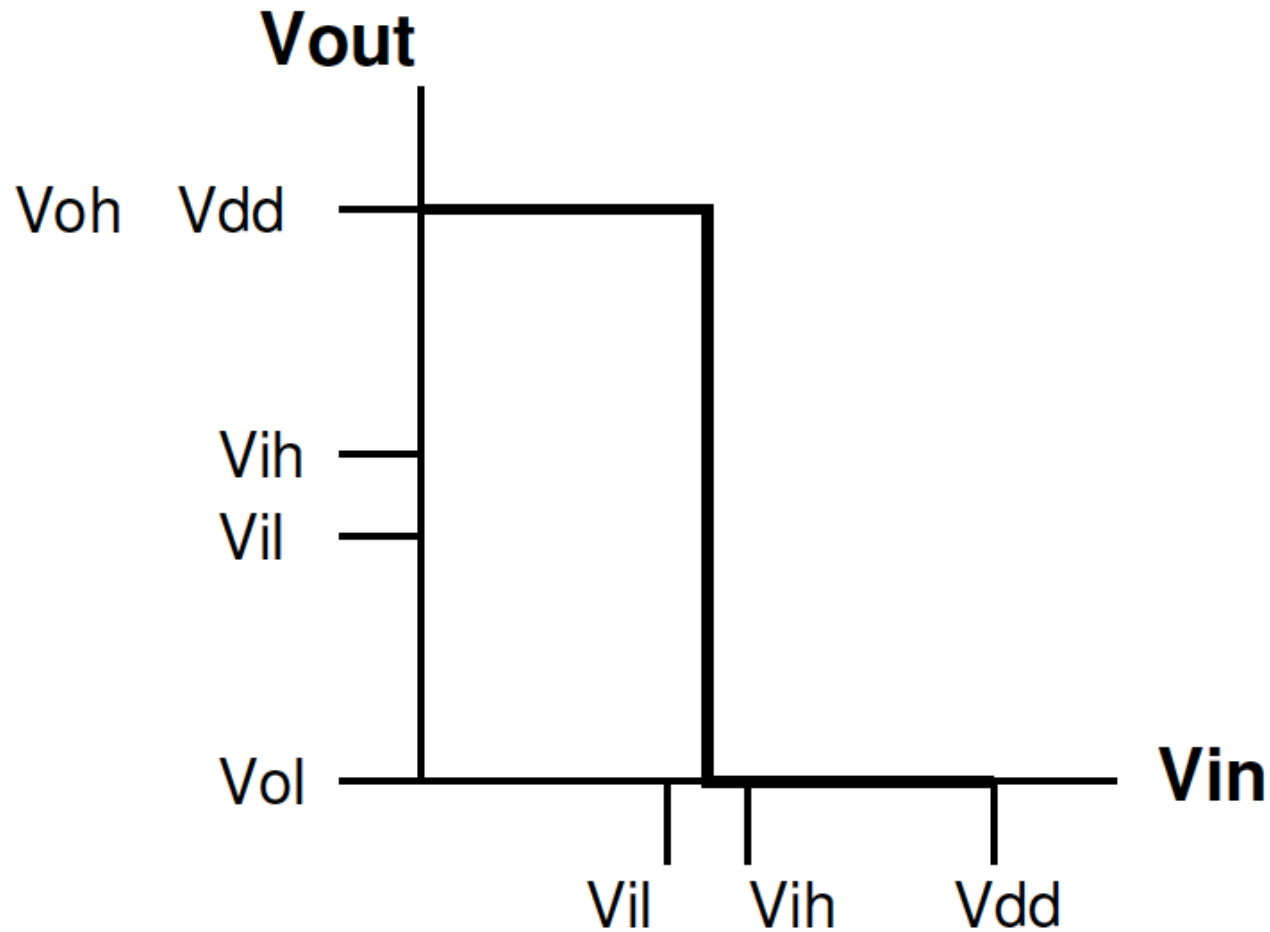

Linear Transfer Function?

□ $V_{\text{out}} = V_{\text{dd}} - V_{\text{in}}$

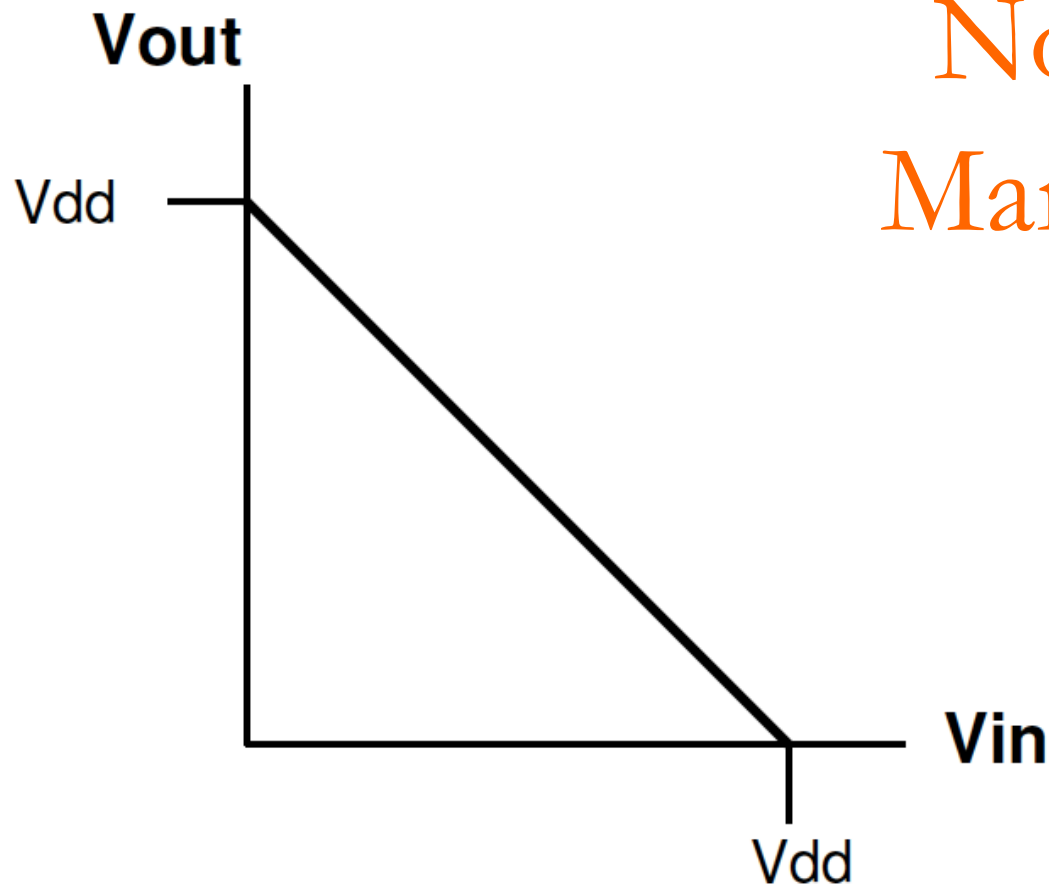

Noise
Margin?

Linear Transfer Function?

- Consider two in a row (buffer)
 - $V_{out1} = V_{dd} - V_{in1}$
- What is transfer function to buffer output V_{out2} ?
 - $V_{out2} = V_{dd} - V_{out1} = V_{dd} - (V_{dd} - V_{in1}) = V_{in1}$

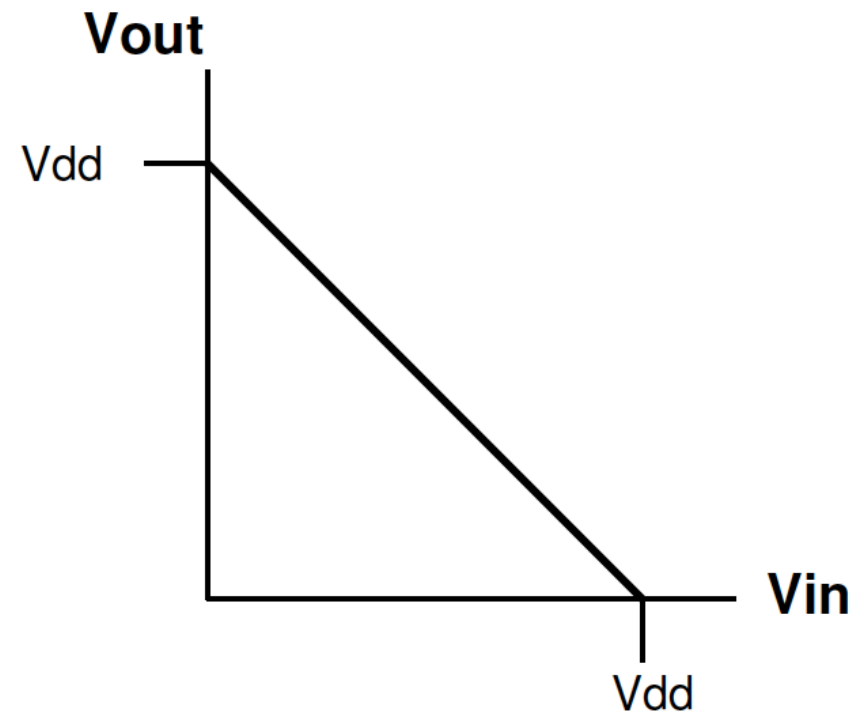
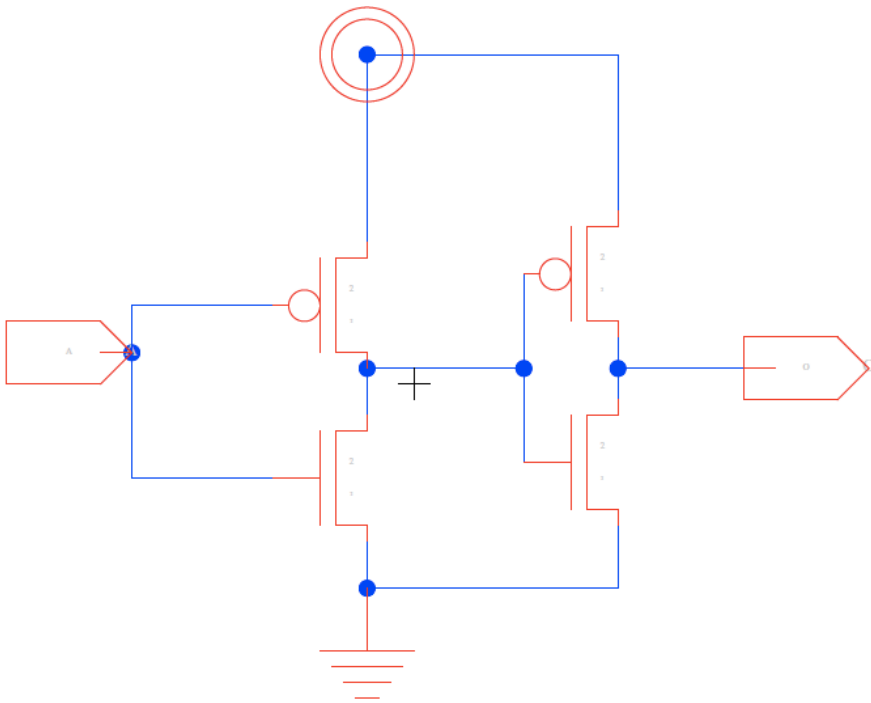

Linear Transfer Function?

- ❑ For buffer: $V_{out2} = V_{in1}$
- ❑ Consider a chain of buffers
- ❑ What happens if V_{in1} drops Δ volts between each buffer?

$$A_{i+1} = A_i - \Delta$$

Conclude: Linear transfer functions do not provide restoration.

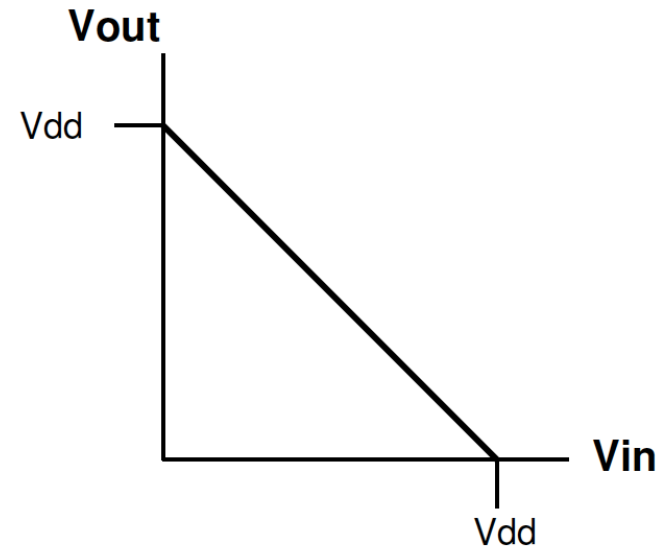



Non-linearity

- ❑ **Need** non-linearity in transfer function
- ❑ Could not have built restoring gates with R, L, C circuit
 - R, L, C are all linear elements



Transistor Non-Linearity

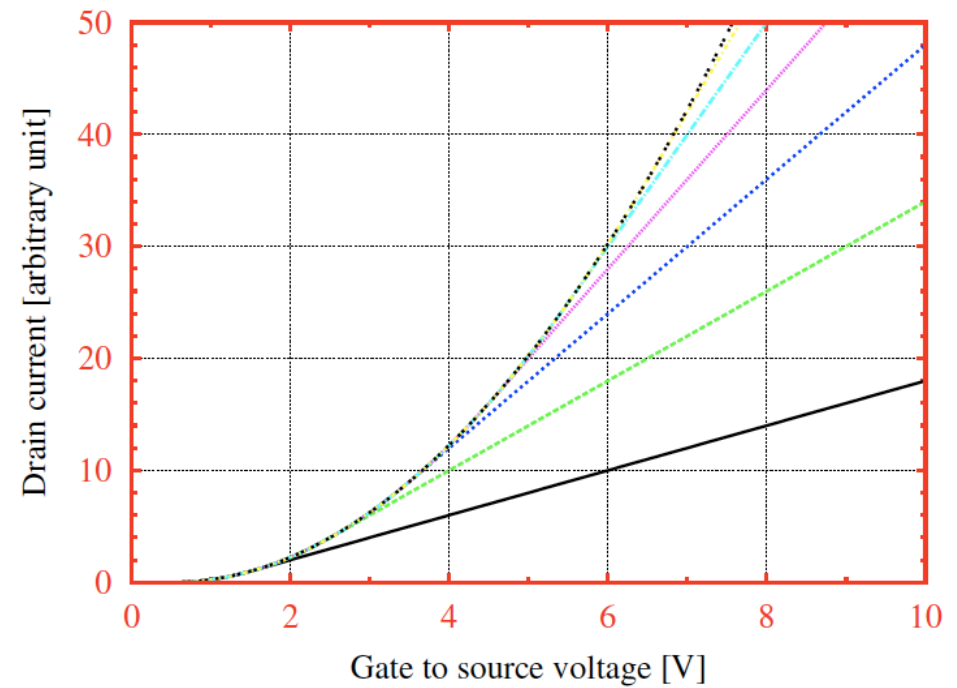
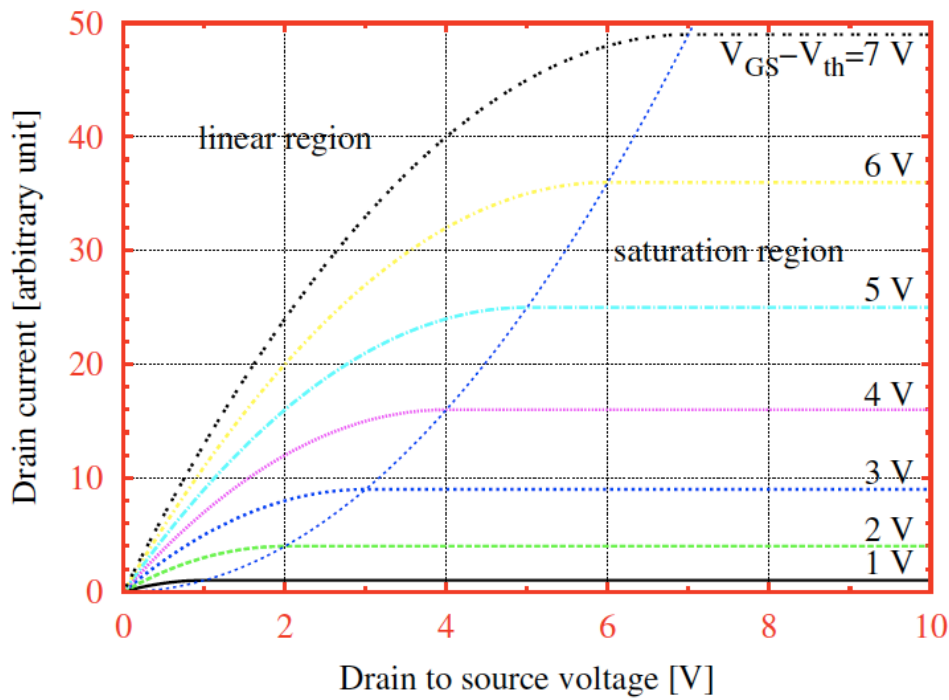



All Gates

- If we hope to assemble design from collection of gates,
 - Voltage levels must be consistent and supported across all gates
 - Must adhere to a V_{IL} , V_{IH} , V_{OL} , V_{OH} that is valid across entire gate set of digital circuit

$$V_{ol} = \underset{g \in G}{MAX} (g \cdot V_{ol})$$

$$V_{il} = \underset{g \in G}{MIN} (g \cdot V_{il})$$

$$V_{oh} = \underset{g \in G}{MIN} (g \cdot V_{oh})$$

$$V_{ih} = \underset{g \in G}{MAX} (g \cdot V_{ih})$$

Big Idea

- Need robust logic
 - Can design into any (feed forward) graph with logic gates and tolerate loss and noise, while maintaining digital abstraction
- Regeneration and noise margins
 - Every gate makes signal “better”
 - Design level of noise tolerance

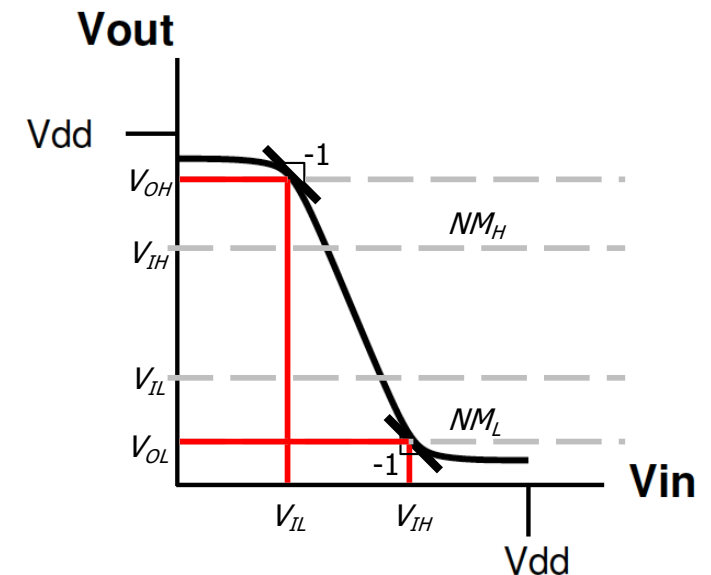



Admin

- ❑ Homework 2 out now due Friday 2/3
 - Will take time to install and learn ngspice
 - START EARLY!!! For troubleshooting
 - Use Ed discussion and office hours for technical difficulty questions
 - Highly recommend you work in study groups/pairs for trouble shooting
 - Tool guides/tutorials on course webpage for help
 - <https://www.seas.upenn.edu/~ese3700/#tools>
 - Get your design workflow setup now
 - EVERYONE will be required to verify this on HW 3



Acknowledgement

- Prof. André DeHon (University of Pennsylvania)
- Prof. Tania Khanna (University of Pennsylvania)