

TCOM 370 NOTES 99-1 NETWORKING AND COMMUNICATIONS

Communication Networks

Allow *Exchange of Information* between *Users*

- *telephone network* for voice communication
- interconnected computers and peripherals, a *computer network*

User:

- Human, application program in a PC, printer, file server

Network:

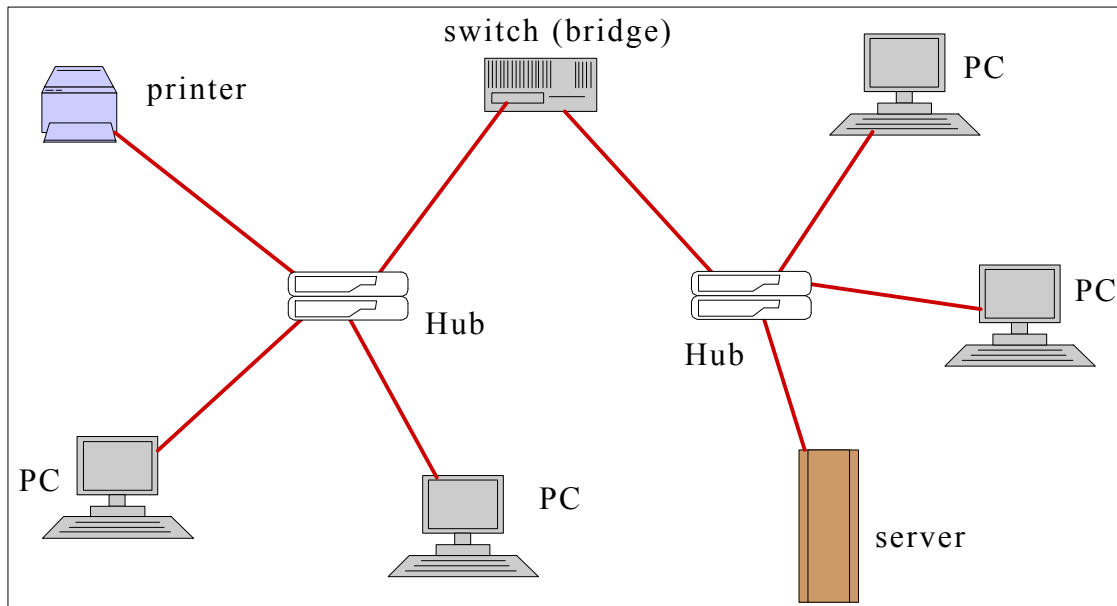

A network of interconnected nodes for information exchange

- Network consists of *point-to-point links* between certain *nodes*.
- All node pairs not connected with dedicated point-to-point links; links can be *shared*
- *Nodes* are *terminal (user) nodes* or *communication (network) nodes*

Information:

Voice, Audio, Image (picture), Video, Text, Data

Information Format:

- **Binary** sequence of binary digits

...00110110101000011110100....

1 byte = 8 bits

Information *Transmission Rate* in bits per second (bps) and *Bit Error Rate* (BER), or bit error probability, characterize the performance of a link or connection through a network.

- Non-binary message, e.g. text or voice, may be converted to a binary representation.
- Text: "alphabet" is finite; assign unique binary pattern to each symbol or letter. The **ASCII code** assigns a 7-bit sequence to each of 128 symbols (upper/lower case letters, numerals, punctuation marks, special (control) symbols.)
- Voice: *sample* the time-waveform at uniform rate, convert (*quantize*) each sample to a finite-precision binary number. Approximation represented as binary sequence.

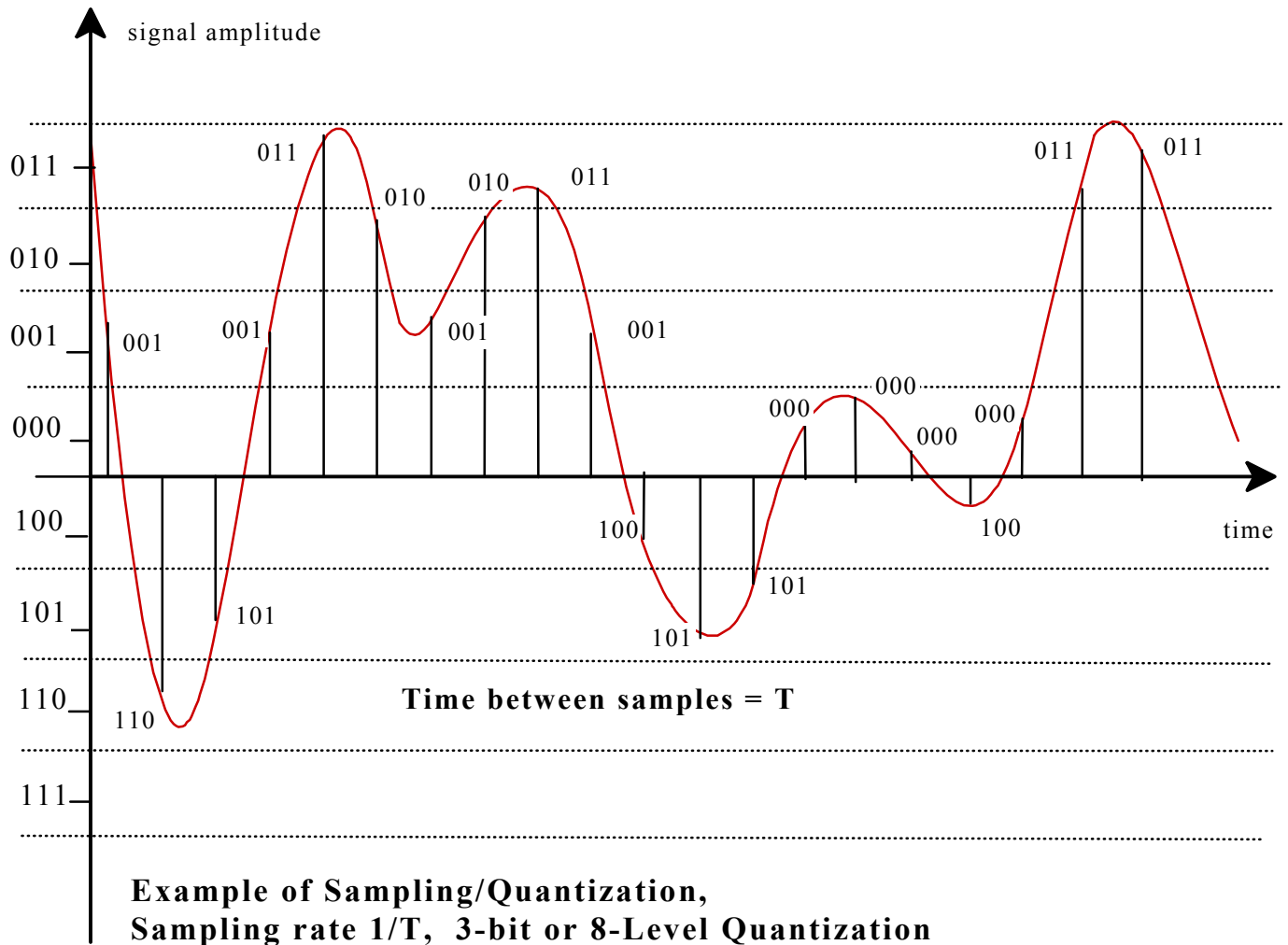

In *telephony*, a sampling rate of 8 kHz (80000 samples per sec) is used with 8 bits for each numerical sample value, giving a *bit rate* of 64 kbps

General Result:

Sampling Theorem: If waveform does not have frequencies beyond a maximum frequency of F Hz., then samples at a minimum sampling rate of $2F$ samples/sec contain all the information in the original waveform

Connectivity Between Terminal Nodes

Circuit Switching:

Common example: Public Switched Telephone Network (PSTN).

Dedicated communication path established between two terminal nodes (e.g telephones) through set of network nodes, during call set-up. Resources are **reserved** for signaling (at 64 kbps in telephony) between the terminal nodes through this path. There is a **call set-up delay** overhead.

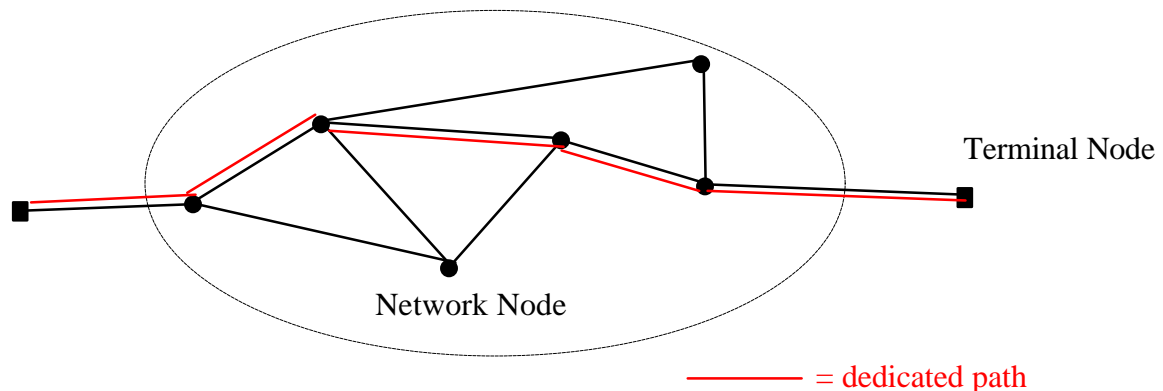

Circuit Switching

Store and Forward Transmission of Packets:

Packet: Group of bits, typically several hundred to several thousand long.

- Terminal node transmits its message as a sequence of **individual packets** through other network nodes to terminal node.

Possible Packet Structure

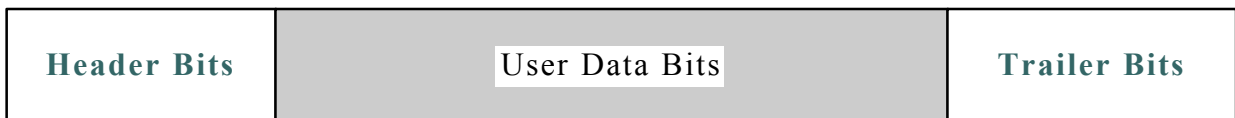

Source address

Destination Address

Sequence Number

Error Control

- Packet forwarded from node to node within network; short packets reduce forwarding delay (complete packet received before forwarding).

- **Numerical Example of Store-and-Forward Switching**

4 hops (point-to-point links) between two terminal nodes; 3200 Message Bits; Transmission rate 9600 bps on all links; 24 overhead bits [Header + Trailer] for each packet; 1024-bit fixed packet size; 1 ms. (0.001 sec) per-hop signal propagation delay.

1 sec. call set-up time for circuit switched connection across 4 hops.

What is total time to send the complete message using circuit switching and packet switching? What is the transmission delay for each bit between the terminal nodes?

Circuit Switching:

3200 bits at 9600 bps \Rightarrow 0.333 sec. message duration.
 total propagation delay 0.004 sec.,
 Total time for message is $0.333+0.004 +1 = \mathbf{1.337 \text{ sec.}}$

Transmission delay is **0.004 sec.**, since bits are not transmitted during call set-up.

Packet Switching:

Number of packets = 4 (1024-24 = 1000 bits of message data for first three packets, fourth packet has 200 bits of message data and 800 dummy bits)
 Packet duration = $1024/9600 = 0.107 \text{ sec.}$

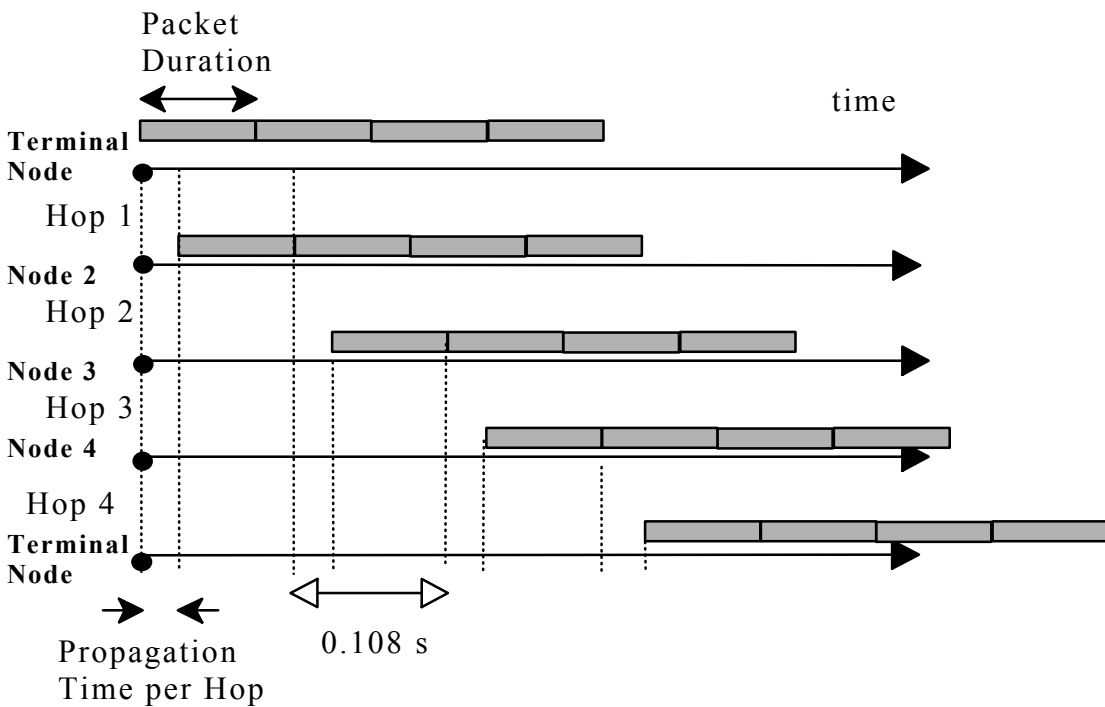

Entire 1024-bit packet received by each node from preceding node in $1024/9600 + 0.001 = 0.108$ s.

Total message time is therefore $4 \times 0.108 + 3 \times 0.107 = \mathbf{0.753}$ sec.
(because there are 4 hops, and 3 packets in succession after the first complete packet is received at terminal node)

Transmission delay is $4(0.001) + 3(0.107) = 0.325$ sec.

Note: Short packets reduce transmission delay due to store/forward nodes. There may also be processing delays at nodes. Shorter packets inefficient due to overhead bits. For circuit switching, set-up time can be a major contribution to message delay.

Datagram Packet Switching:

Different packets of a message may take different paths. Packets routed from node to node independently of other packets, based on destination address and conditions in the network.

(Analogy: U.S. Post Office mail transport!)

- Used in Wide Area Networks and in *The Internet*.
- More efficient use of links (different user packets at different times on same link; statistical multiplexing gain)
- Data rate conversions possible
- other considerations: no call set-up needed, packet delay vs. call blocking in congested conditions, packet prioritization possible, out-of sequence packets,

Virtual Circuit Packet Switching:

Message sent in the form of **short** fixed length packets (to minimize transmission delay); but a **virtual** circuit is established over some fixed path between terminal nodes during call initialization. Links forming this path may, however be shared by other user packets; the path is fixed for the whole message, but need not be used exclusively by it.

- (Asynchronous Transfer Mode (**ATM**) Networks: 53 byte packets)

The Internet

- World-wide interconnection of individual networks.
- Each host computer *name* (e.g. seas.upenn.edu) has unique corresponding 4-byte or 32-bit internet *address* (e.g. 130.91.5.147).
- Logical organization for Internet names and addresses. First one to three bytes of internet address is network identifier, rest form the specific host address on this network.
- Domain Name System (DNS) allows *name servers* to provide addresses corresponding to names, to requesting hosts.

Internet Protocol or **IP** refers to network protocol that allows end-to-end delivery of packets between terminal nodes or hosts on the Internet. IP packets may be up to 64 kbytes long.

Transmission Control Protocol (TCP) supervises packet transport. Allows *error-free packet delivery in sequence* for a given connection, by using error detection with re-transmission requests. Provides for *congestion control* by implementing flow-control procedures at the end-nodes.

Shared Ethernet - A Local Area Network (LAN)

Concept: A packet communication scheme with the following features:

- **Shared** communication medium to which a number of computers (nodes) are connected.
- Medium may be a passive cable to which nodes are connected, or electronic "hub" to which nodes are connected by wire pairs. (e.g. 10Base-2 or 10Base-T ethernets).
- The network extends over a **small geographical area** (e.g. within a building).
- The medium allows a **high bit transmission rate**, say 10 Mbps or 100 Mbps.
- All nodes have equal access to the medium. Node can send **packet** successfully across medium to another node if medium is not carrying any other packet at the same time (i.e. no packet **collision**)

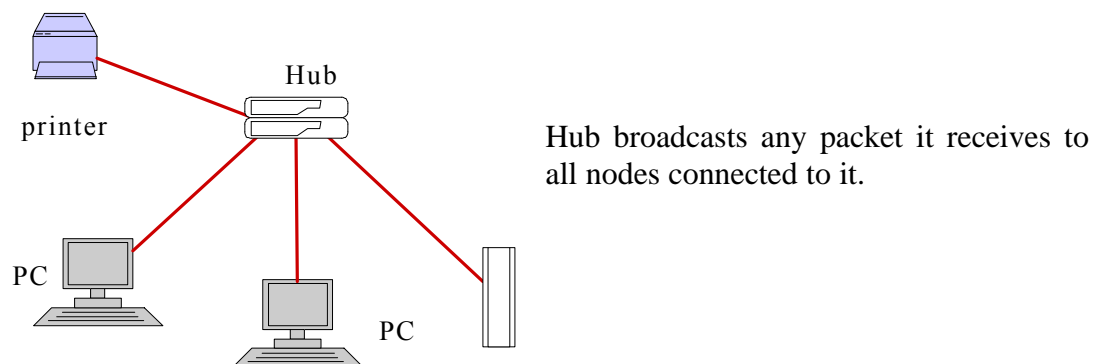
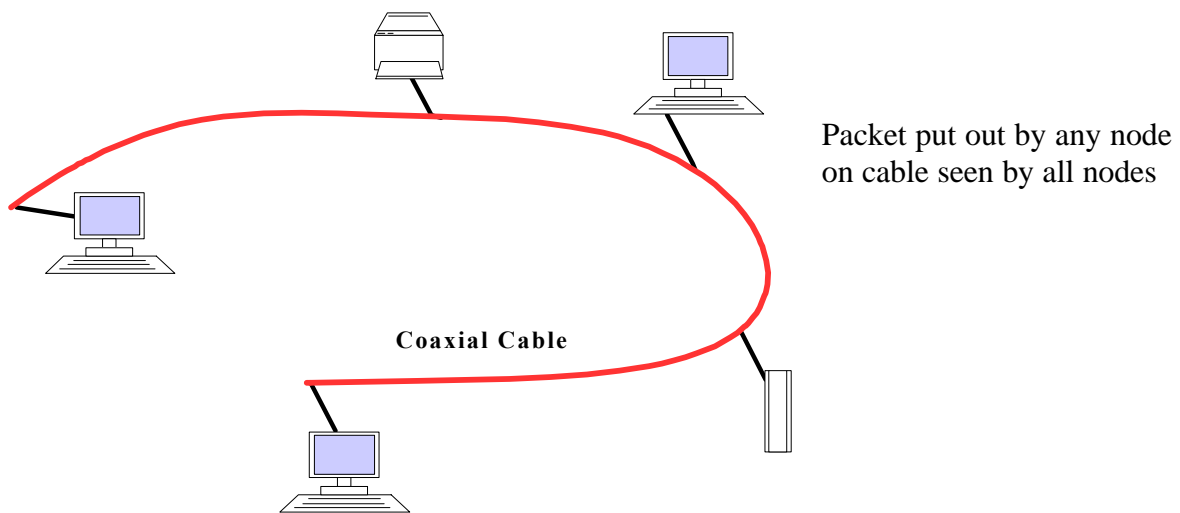

Medium Access Control: Carrier Sense Multiple Access/Collision Detection (CSMA/CD)

- If packet sent by node "collides" with another, result is garbled electrical signal.
- Nodes *detect* "collision" by monitoring nature of electrical activity on cable; or, electronic hub sees packet arrivals on more than one port, and sends out a "collision" signal that all nodes detect.
- Thus node knows when its packet has collided with another. It then *backs off* for a random time duration, and attempts to re-transmit.
- Before any packet transmission, node also *senses* for ongoing packet transmission to avoid colliding with it
- Collision detection is still necessary because a node may start its transmission just after another node has started, without knowing about that node's transmission because of propagation delay.

If maximum transmission rate is R bps on medium, there are many nodes, and all nodes have messages to transmit (heavily loaded network), under optimum conditions on average a fraction η of R is the actual throughput in bps on the medium because of collision losses. The fraction η is called the efficiency, its value depends on the *maximum propagation delay* on the medium and on the *packet length*.

Other LANs:

Token Ring, Fiber Distributed Data Interface (FDDI), etc.

Ethernet Address: A unique **48-bit sequence** for each ethernet device. Ethernet packets contain source and destination ethernet addresses. Ethernet address of a node is not related to its network address.

Address Resolution Protocol:

An ethernet node A can discover the ethernet address of another node B with network address "N" on the same network by sending a "broadcast" ethernet packet that is read by all other nodes. The packet message is "Node of network address N, please respond". The response is an ethernet packet and carries the ethernet address "Y" of the responding node B. Node A adds the information "Network Address N = Ethernet Address Y" to its own directory.

Interconnected Ethernets:

Switch or Bridge: Device with two or more ports, each connected to an ethernet. Forms a bigger ethernet.

- Each port sees an ethernet connection.
- Packet incoming on a port is examined and may be **copied** out on another port.
- Switch can read ethernet addresses of packets but does not modify them.
- Switch has ethernet **address lists** associated with its ports (list of addresses each port has connection to.)
- Switch copies packet to another port if incoming packet addressed to node on that port. Copies to all ports (save the incoming) if address not in its lists.
- Updates lists as it learns who is connected where.

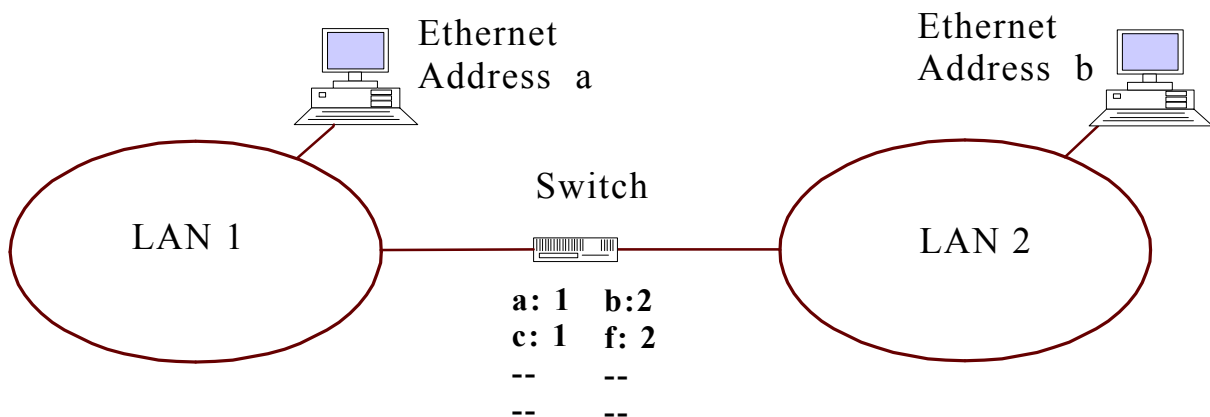

Routers:

More sophisticated device with multiple ports each connected to a network.
Assume the local networks are ethernet.

- Each router port has an ethernet address.
- Router forwards incoming ethernet packets based on **network address** of destination.
- Router **modifies** ethernet addresses in forwarded packet.
- Router makes decision on **best outgoing path** for packet when destination is not on an adjacent network connected to a port.

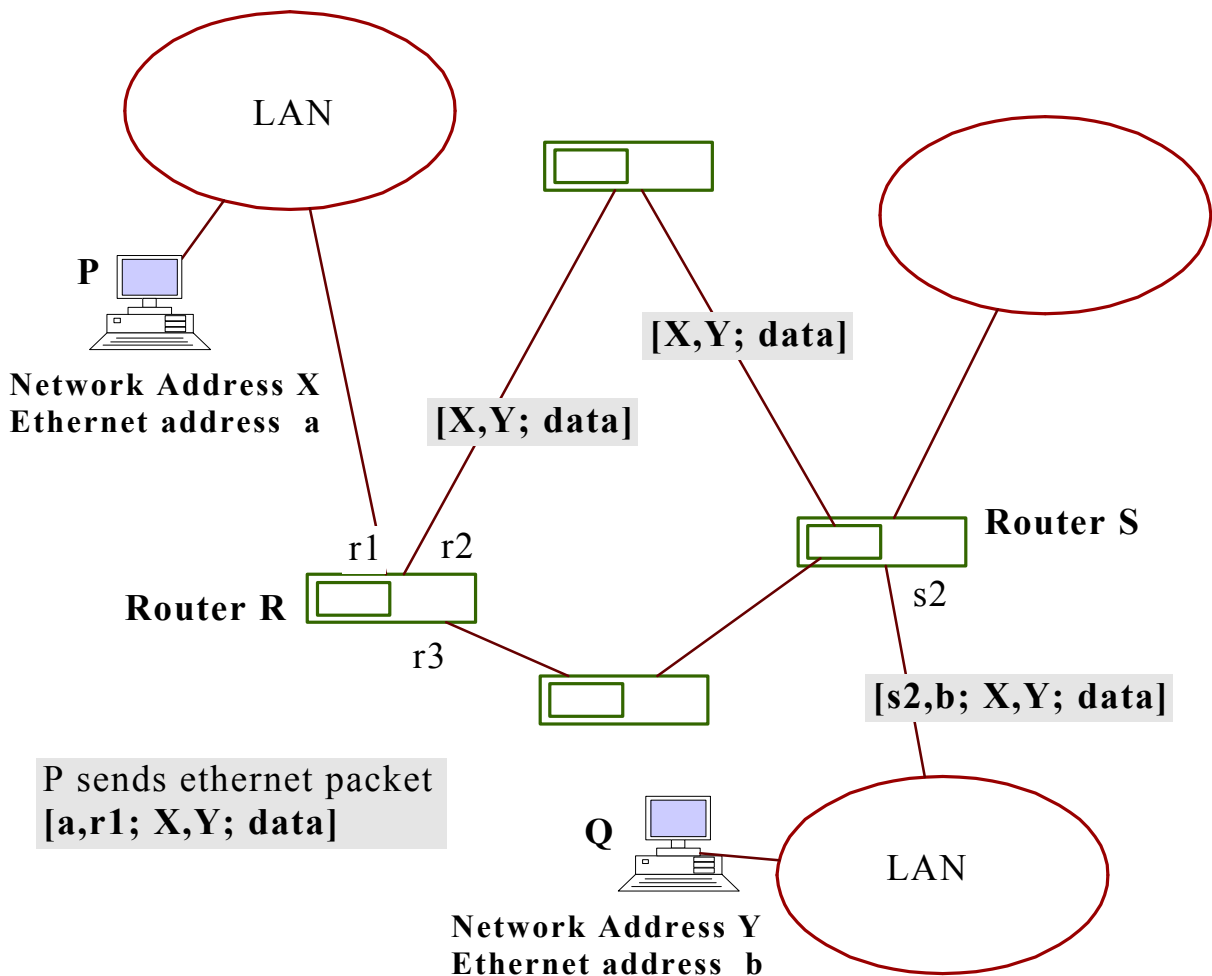

Protocol Architecture

TCP/IP Protocol Architecture

Application Layer (e.g. FTP, SMTP)
Transport Layer (TCP)
Internet Layer (IP)
LAN/Link
Physical Layer

OSI (Open System Interconnection) Reference Model

Application Layer
Presentation
Session
Transport Layer
Network Layer
Data Link Layer
Physical Layer