



Pediatric Dynamometer

SUNFEST Summer 2007



Patrick Duggan, PC/Columbia University, ME
Dr. Jay Zemel, University of Pennsylvania, ESE
Dr. Babette Zemel, University of Pennsylvania, CHOP

Background



- **CHOP initiated project**
 - **Effects of exercise on bone-density**
 - **Study of pre-teens suggests correlation**

- **Other gauges of activity**
 - **Surveys are unreliable**
 - **Force plates impractical**

- **Peak force on foot is of particular interest for researchers**

Solution-Pediatric Dynamometer

- *In-shoe device to measure force*
- *Measure force using PVDF sensors*
- *Store data for subsequent analysis*



Dynamometer materials

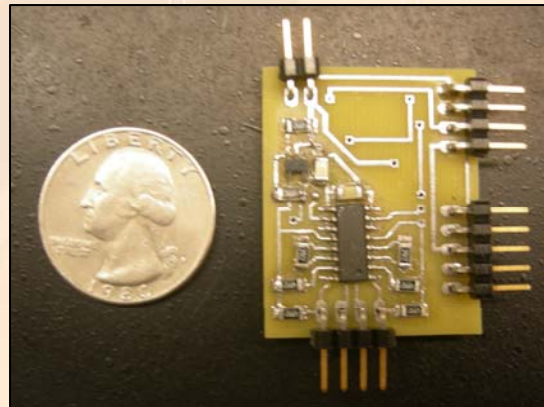

Dynamometer circuitry



PVDF film

Design of the PD

Finished

- **Electronics and programming**

Unfinished

- **Integrated design of PD**

Requirements for the design:

- **Accurately measure force within 5%**
- **Be inconspicuous to the user**
- **Inexpensive and easy to produce**

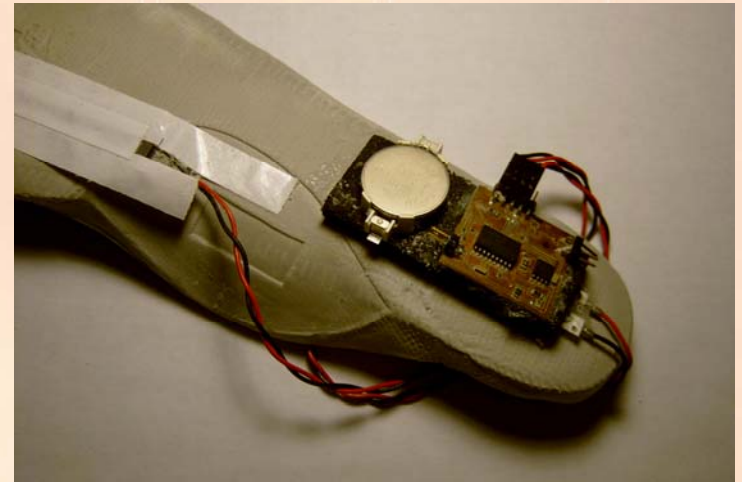

Foot-PAD design attempt

Basics of the PD Design

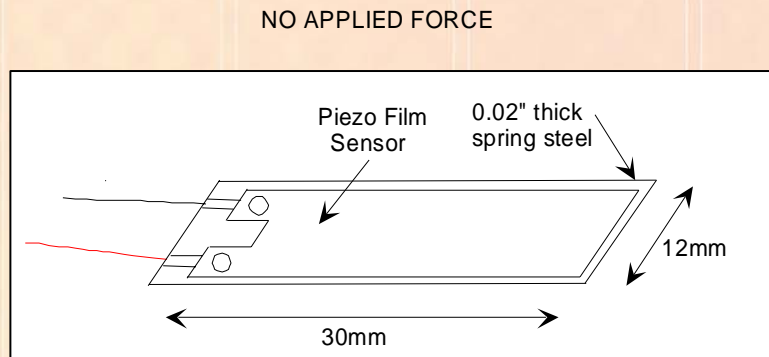

" UP STEP "

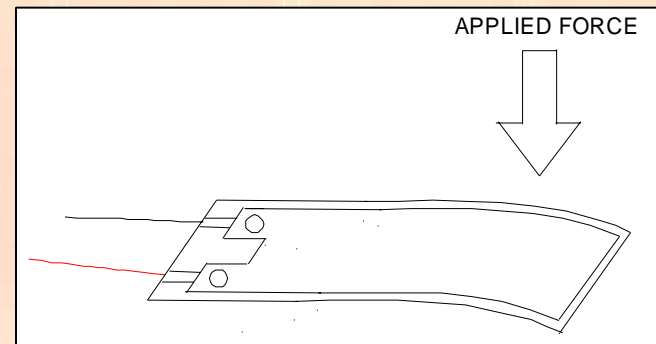

" DOWN STEP "

Mechanical Stress → Proportional Tensile Strain
Strain → Proportional Polarization
Polarization → Proportional Charge

Observing the generated voltage allows us to determine an unknown mechanical stress.



Potential Ideas

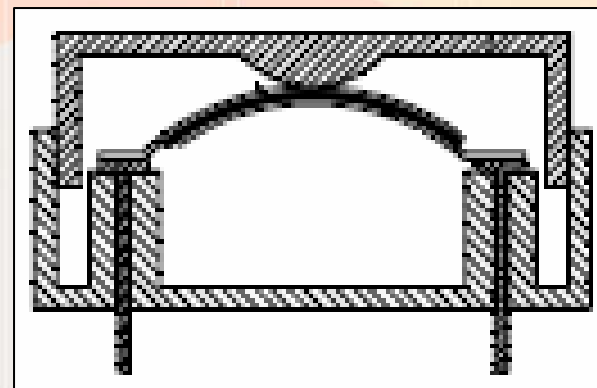
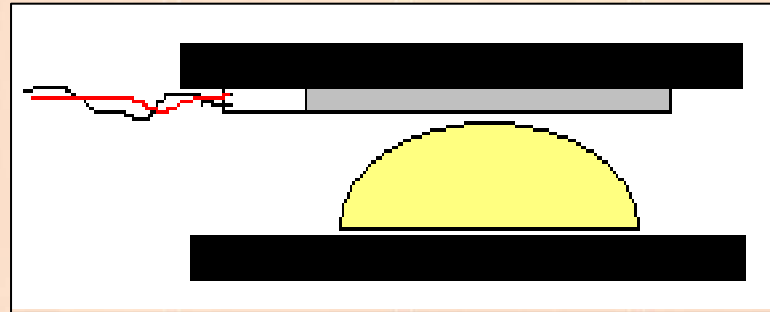
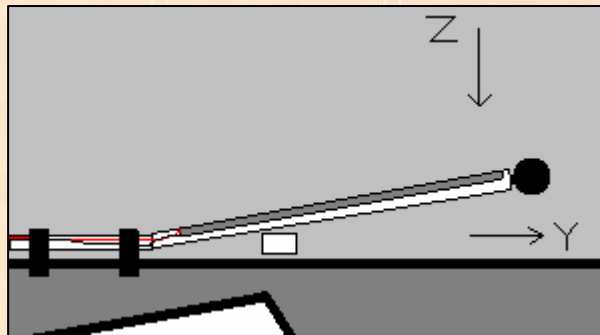

Testing

Periodic Motor

- Motion simulates walking
- Weight and foot simulate force

Scale

- Measure applied force, voltage
- Create sporadic forces

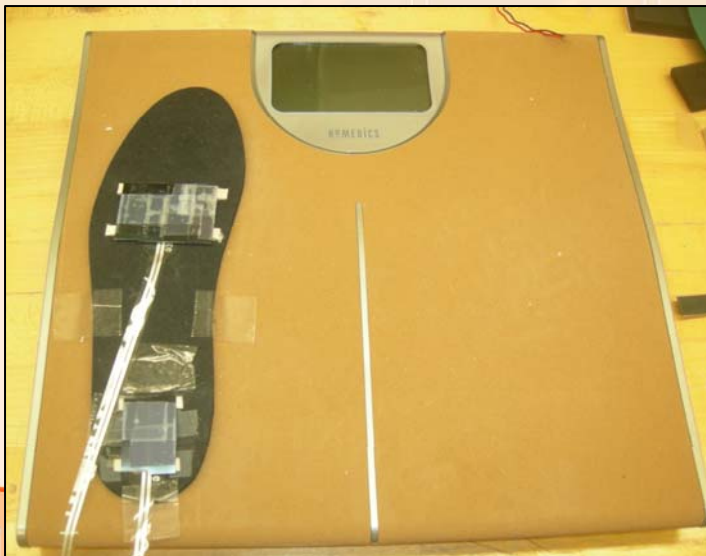

(left) Scale used to measure applied force on design



(above) A simulation used to test designs.

Design Results

General design established!

- uses “bridge” design
- accuracy
- comfort

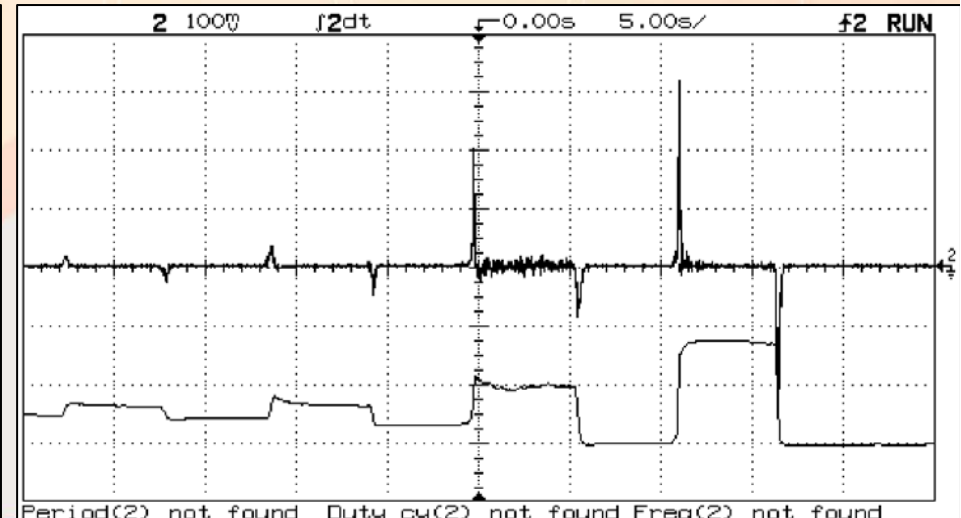
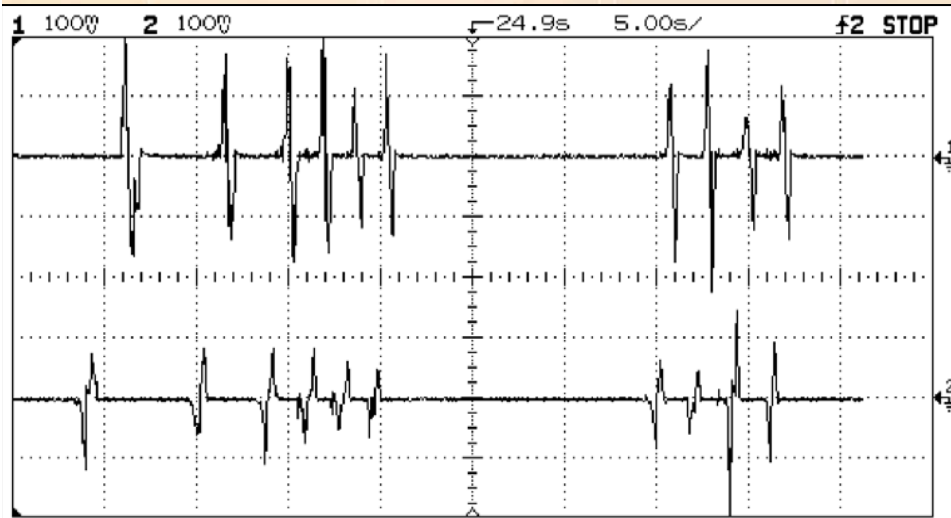
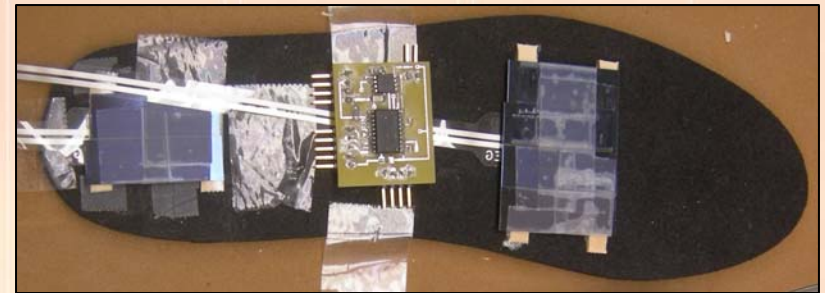
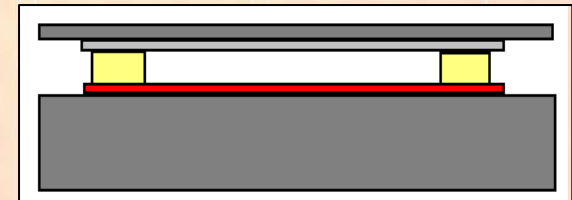

Future Work

Modeling techniques to optimize design

- *Width of steel*
- *Height of Supports*
- *Elastomer Stiffness*
- *Placement of PVDF*
- *Support Material*
- *Size of PVDF*

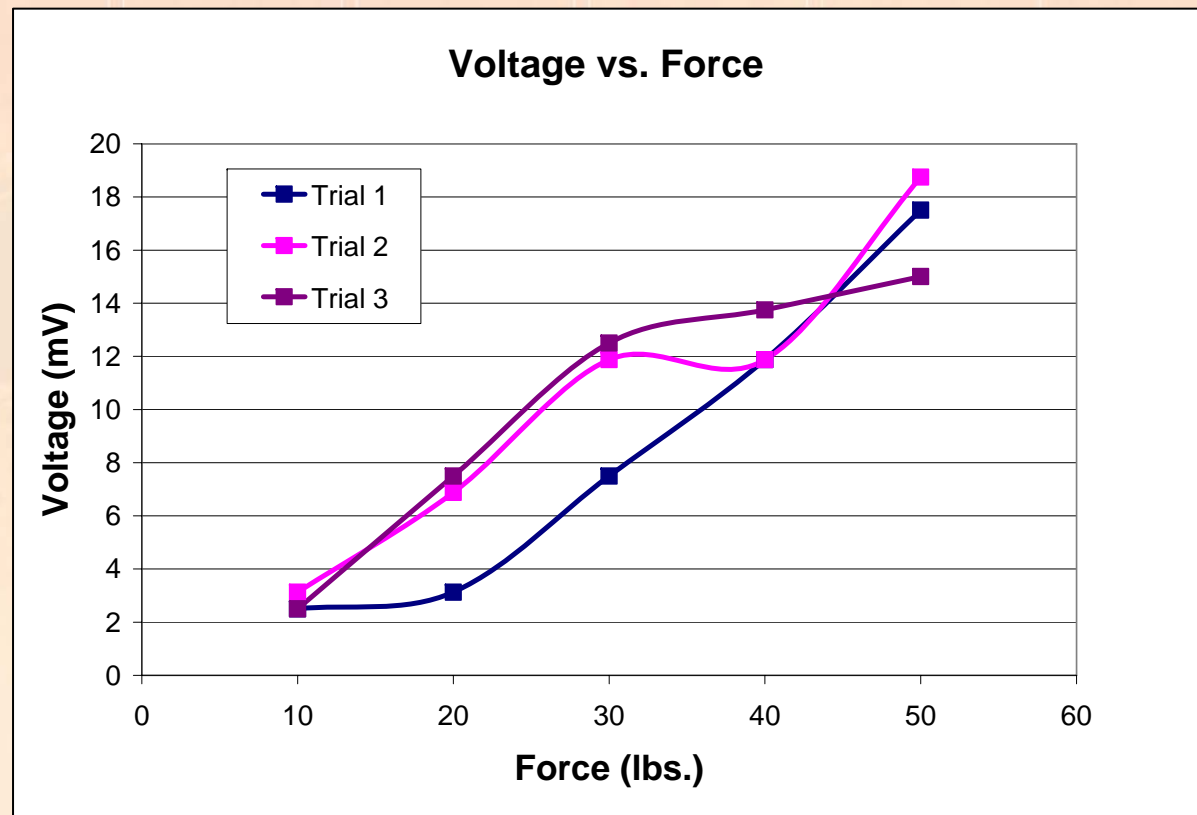

Summary

- *CHOP: Method needed to study bone growth and development of children.*
- *Conclusions can be drawn from an analysis of physical activity.*
- *Designs were tested throughout the summer research.*
- *Bridge-like design works best, but not accurate enough.*
- *Future work needs to optimize design, material properties.*



Acknowledgements

Dr. Jay Zemel, ESE

Dr. Babette Zemel, CHOP

Dr. Jan Van der Spiegel, ESE

David Joffe

RCA Lab, Dr. Santiago's Lab

SUNFEST 2007

University of Pennsylvania

National Science Foundation



10100101010011110100001001011101001011010010110101010111010000100101001001

Citations

KJ Mackelvie, HA McKay, KM Khan, PR Crocker. A school-based exercise intervention augments bone mineral accrual in early pubertal girls. J Pediatr. 2001 Oct; pp. 139(4):501-508.

F. Elgar, C. Roberts, C. Tudor-Smith, L. Moore; Validity of self-reports height and weight predictors of bias in adolescents. J Adolesc Health. 37(5): pp. 371-375. Nov. 2005.

G. Welk, C. Corbin, D. Dale; Measurement issues in the assessment of physical activity in children. Res Q Exer Sport, 71 (2nd Suppl): S 59-73. Jun 2000.

Unpublished Senior Design Report: A. O'Donnell; Pediatric Dynamometer. Univ. of Pennsylvania, pp. 28-29, 2007.

A. O'Donnell, Pediatric Dynamometer. SUNFEST 2006, Center for Sensor Technologies, Univ. of Pennsylvania, 2006.

United States Patent #4,814,661: Ratzlaff et al., Systems for measurement and analysis of forces exerted during human locomotion; 1989.

Unpublished Senior Design Report: M. Kam, D. Tran; Flexible Pediatric Step Monitor for Bone Health Studies. Univ. of Pennsylvania, 2006.

Unpublished Senior Design Report: L. Lamptey, J. Sin, M. Wong; Pediatric Step Monitor for Bone Health Studies. Univ. of Pennsylvania, 2005.

Measurement Specialties Inc., Norristown, PA. Piezo Film Sensors: Technical Manual. April 1999.

