

16 A Bioreactor Benchmark for Adaptive Network-based Process Control

Lyle H. Ungar

16.1 Introduction

As new techniques for adaptive networks such as those described in the first part of this book are developed, it becomes important to test these techniques on a variety of realistic problems to see where they work well and where they need further refinement. Chemical process control offers a fruitful set of test beds and benchmarks for the development of new control algorithms. Chemical processes are often highly nonlinear and difficult to control, yet easy to make approximate models for. The problem of controlling them using conventional controllers is widely studied. This chapter compares chemical and robotic process control and suggests a problem in the control of bioreactors which gives a sequence of problems of increasing difficulty.

Process control of chemical plants is an attractive application because of the potential benefits to both adaptive network research and to actual chemical process control. Control of chemical systems such as reactors and distillation columns has been extensively studied (Morari and Zafriou 1989). They provide, in fact, the major current application of adaptive control, which includes the set of techniques against which adaptive network-based controllers will need to compete in the scientific and commercial marketplaces. Many of the approaches developed in "conventional" adaptive control also apply directly to adaptive network-based control. Studies of convergence, robustness and stability that are done on adaptive controllers will eventually need to be done on network-based controllers as well. However, in the quest for systems with provable properties, traditional control has neglected some attractive but more complex control methods. Work on adaptive networks can stimulate adaptive control by suggesting new approaches, algorithms, and architectures.

This chapter describes the context of work in adaptive control and the industrial need for better controllers within which work using adaptive networks must establish itself. Some of the features that make chemical reactor control difficult and some of the differences and similarities of chemical process control and robotic control are described. The final section describes a proposed benchmark bioreactor control problem and the use of an adaptive network-based controller to control it.

16.2 Current Approaches to Adaptive Control

One of the most promising uses of adaptive networks is as the model of the plant or process being controlled in a conventional model-based controller. Many conventional adaptive controllers use models which can be recast as being based on linear adaptive networks. In a typical form, the plant output at time $k+1$, o_{k+1} , is predicted based on the previous plant outputs o_k and inputs i_k .

$$o_{k+1} = \sum_{j=1}^n a_j o_{k-j+1} + \sum_{j=1}^n b_j i_{k-j+1}$$

The parameters a_j and b_j are fit from plant data. This formula can be written as a linear neural net with $2n$ inputs and one output. This linear equation can also be replaced with a nonlinear multiple-layer adaptive network to allow more accurate modeling of nonlinear plants. See (Bhat and McAvoy 1989) for a detailed example.

Other model-based architectures can also be used. Internal model control (Garcia and Morari 1982), for example, uses both a plant model and an inverse plant model. An adaptive network can be used in place of the model and inverse model (see figure 16.1). The model is trained using plant input and output as its inputs and outputs, while the inverse model is trained by using plant output and input as its inputs and outputs, respectively. Internal-model control has been extended to multivariable systems (Garcia and Morari 1982) and specialized so that the control algorithm can be formulated as a linearly constrained optimization problem (called in this case Dynamic Matrix Control or DMC) (Cutler and Remaker 1979). It has also been extended to nonlinear systems (Economou and Morari 1986, Li and Biegler 1987). This work demonstrates the value of using a separate model of the process for nonlinear as well as linear processes and provides a framework for doing so. However, conventional control (unlike adaptive network-based control) does not usually address the problem of determining the model of the process.

Adaptive networks can also be a part of adaptive controllers such as self-tuning controllers (Astrom et al. 1977) which adapt parameters as the process is being controlled. Self-tuning regulators are composed of two loops: an inner loop which consists of the process and an ordinary linear feedback regulator, and an outer loop which adjusts the parameters of the regulator in the inner loop. Note that these controllers do not

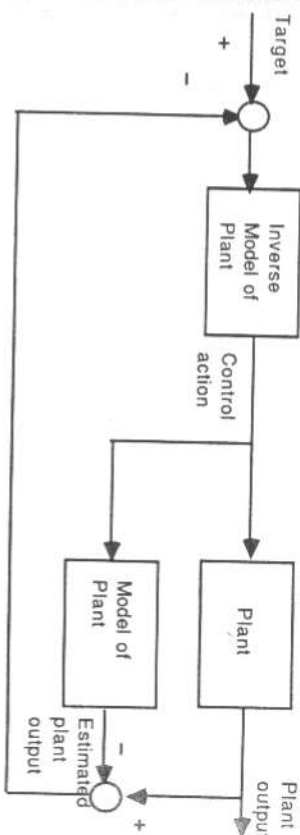

Figure 16.1
Internal model control structure.

use an explicit model of the process; knowledge of the process is implicit in the controller parameters.

The vast majority of the work on adaptive control has been on methods for linear or weakly nonlinear systems. This has some justification in that for small enough variations, any continuous system is linear; it also allows rigorous conclusions to be proven about controller behavior. Unfortunately, variations in the real world are not always small enough. Linear adaptive control schemes have been widely studied and are widely used in industry. (By linear, we mean systems which when not adapting give linear control.) Nonlinear adaptive controls are less well developed and less well understood. Nonlinear self-tuning controllers can offer substantially better performance than linear controllers (Anbumani et al. 1981, Svoronos et al. 1981, Lachmann 1982), but the methods that have been used for nonlinear adaptive control are limited to processes with specific nonlinearities and often have difficulty handling time delays. Many controllers for nonlinear systems make the unrealistic assumption that exact nonlinear models of the process being controlled are known. Even those controllers which can include arbitrary nonlinear functions of the output and old inputs are typically limited to single input single output systems (Agrawal and Seborg 1987). Adaptive networks appear to be ideally suited for modeling highly nonlinear multivariate systems; it is therefore to be expected that their major contribution will be in nonlinear control.

16.3 Motivations for Chemical Process Control

In spite of the extensive work on self-tuning controllers and model-reference control, there are many problems in the chemical processing industries for which current techniques are inadequate. As was mentioned above, many of the limitations of current adaptive controllers arise in trying to control poorly modeled nonlinear systems. For most of these processes extensive data are available from past runs, but it is difficult to formulate precise models. This is precisely where adaptive networks can be expected to be useful. A representative set of commercially important problems is briefly described below.

Many chemical processes are strongly nonlinear. Nonlinearities may be intrinsic to the physics or chemistry of a process as in supercritical extraction, in which complex phase behavior leads to sensitive dependence of operation on operating conditions and control (Panagiotopoulos and Reid 1987). Nonlinearities may also arise through the close coupling of simpler processes. For example, when heat integration is used to save energy, the processes become more tightly coupled, more multivariate and more difficult to control.

Older technologies also present challenges. Distillation is a highly nonlinear process, and one of the most widely studied control problems (Shinsky 1977). Even production of products as "mundane" as soap flakes can offer major challenges. One major manufacturer has a process that produces good quality soap flakes during high volume production, but is erratic (depending on operator skill) during low volume production. No good first-principles models of the process exist and there are too many control parameters to experiment blindly. Processes such as aluminum casting offer similar challenges. Different rates of cooling lead to different regimes of operation and produce aluminum with different properties. Given some simulation data and experience from past runs one wishes to produce an "optimal" control schedule.

Chemical reaction systems also present important and widely studied control problems. Extensive theoretical and experimental studies have been made of both batch and continuous stirred tank reactors (CSTRs). Although such reactors can be (approximately) described by simple equations, they can exhibit complex behaviors such as multiple steady states and periodic and chaotic behavior (Agrawal et al. 1982, Chang and Chen 1984). One example of such reactors which presents special problems is bioreactors. They are difficult to model because of the complexity of the living organisms in them, and can vary from batch to batch. They are also difficult to control because one often

cannot measure online the concentrations of the chemicals being metabolized or produced. Bioreactors can also have markedly different operating regimes, depending on whether the "bugs" (bacteria or yeast) are rapidly growing or producing product. Model-based control of such reactors thus offers a dual problem: determining a realistic process model and determining effective control laws in the face of inaccurate process models and highly nonlinear processes.

Of the problems mentioned above, I think that a version of the bioreactor or CSTR problem is the most accessible to experimentation and use in the testing of adaptive networks. Strong nonlinearities give behavior sensitive to the parameters in models and the structure of the models. Very different behavior can be observed in different operating regimes, including complex dynamics, yet one can capture enough of their behavior in two equations to offer a significant control challenge (see below). Multivariate versions of the problem arise when one wishes to use control of temperature and feed rates of different nutrients to optimize production of different products.

16.4 Comparison of Chemical and Robotic Process Control

In spite of their obvious similarities, process control and robotic control differ in several important ways. Chemical plants are mostly operated continuously, and try to respond to and minimize the effect of disturbances, rather than (for example) follow specified trajectories. Much more work is needed in devising more powerful methods of learning models of dynamic systems (or learning to correct models derived from first principles so that they describe real plants) and in developing reinforcement learning schemes appropriate to control applications. Algorithms must be modified to handle essentially infinite sequences of data, and to overcome problems such as forgetting. Real-world problems with variable time lags and large amounts of data add to the challenge. Speed is also a problem for some real-time applications.

On the other hand, some aspects of chemical process control are simpler than robotic control. Chemical process control problems do not have the complicating questions of visual interpretation so common to robotics. Fairly accurate (although sometimes erroneous) readings of temperatures and pressures are virtually continuously available and a fairly clear identification and control problem can then be posed. If anything, the abundance and frequency of measurements poses a challenge:

how can all of this data be efficiently used to improve one's model of the process? When one has an accurate set of equations describing the plant, this is a question of fitting the parameters ("system identification" in control jargon). When one does not, more general equational forms such as those offered by adaptive networks are needed.

One way to approach the problem of developing test problems and benchmarks is to ask the question, "What makes a system hard to control?" Much of the difficulty in controlling any process comes from the complexity of the process being controlled. This complexity can be described in several ways. Highly nonlinear systems are difficult to control, particularly when they have complex dynamics (such as instabilities to limit cycles and chaos). Difficulties can often be presented by constraints, either on the control parameters (e.g., there is a maximum rate at which the system can be heated) or in the operating regime (e.g., heating above a certain point leads to a runaway reaction). Lack of exact knowledge of the process, of course, makes control more difficult.

The above problems are, of course, common to robotics control problems. Other difficulties such as significant lag times between the time a control action is taken and the time a response is observed are more characteristic of chemical process control. Delays in response mean that the system is not invertible. They also create a temporal credit assignment problem: it is not trivial to determine which results should be credited to a given control action. Many chemical processes also have a spatial credit assignment problem: the systems have many sensors and controllers (are multiple-input-multiple-output, or MIMO), and it is not clear how to connect sensors and controllers or how changes to multiple controllers interact.

Optimal control of many chemical plants also requires systems which make use of predictions of future behavior. This can occur in time-varying processes such as batch processes, where one wants to optimize over time, or it can occur in fairly simple continuous systems, where nonlinearities can cause "inverse response" (a change to a control parameter that may initially move the process in a direction opposite to its longer term effect).

Finally, chemical problems are different from robotics control problems in that experimentation must be much more limited and conservative. Although it may be feasible to have a robot try—but fail—fifty times to put a peg in a hole, it is not acceptable to have a reactor try—but fail—fifty times to avoid producing product which is off specification.

Unlike many "toy" problems, one cannot afford in these applications to stumble around and experiment for a long period prior to achieving good performance. This means—among other consequences—starting from models based on first principles and improving with a relatively conservative learning algorithm.

16.5 Adaptive Control Benchmarks

The pioneering early work on machine learning for control was strongly supported and shaped by a few benchmark control problems. The characteristics of the problem being solved and the techniques used to solve it interact closely; different problems call for different approaches and different controller architectures and algorithms. Benchmarks should be carefully examined to see why they are hard. An influential early model control problem is the problem of balancing a pole (or an inverted pendulum) on a moving cart (Michie and Chambers 1968). (See figure 16.2) In this version of the problem, the possible actions on the cart are discretized into a positive or negative force of fixed magnitude, and the state of the pole and cart is similarly quantized into a small set of discrete regions (direction the pole leans, rough position of the cart) for sensory purposes. Reinforcement or rather, in this case, punishment comes only when the pole leans over too far, or the cart exceeds the bounds of the track. This problem has come to be used as a test bed for trying and comparing new algorithms (Widrow 1964; Barto Sutton, and Anderson 1983; Anderson 1987; and earlier chapters in this volume). The difficulty of the problem comes from the delayed reinforcement and inaccurate measurement of state variables.

The control problem posed below is in some ways easier, and in many ways different from the pole balancing problem. The pole-balancing problem has been very useful because it captures the aspect of delayed feedback. Chemical plants also often have delayed feedback, but that is the central feature which makes their control difficult. The goal of chemical process control is quantitative (maximum production of a chemical) rather than qualitative (not falling over). The feedback available to chemical plants and robots is often of better quality than that of the broom-balancer. The error signal and the possible actions are generally continuous rather than discrete and many more measurements and actions are available. Also, an approximate model of the process is usually available.

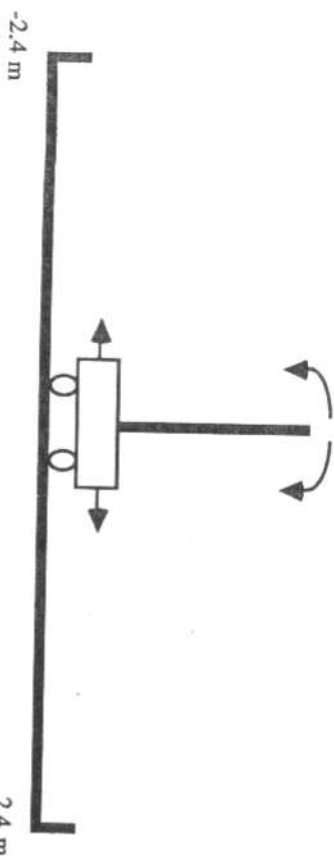

Figure 16.2
"Pole-balancing" problem.

16.6 A Benchmark Bioreactor Control Problem

Chemical systems can be relatively simple in that they have few variables, but still very difficult to control due to strong nonlinearities which are difficult to model accurately. A prime example is the bioreactor. In its simplest form, a bioreactor is simply a tank containing water and cells (e.g., yeast or bacteria) which consume nutrients ("substrate") and produce products (both desired and undesired) and more cells. Bioreactors can be quite complex: cells are self-regulatory mechanisms, and can adjust their growth rates and production of different products radially depending on temperature and concentrations of waste products (e.g., alcohol). Systems with heating or cooling, multiple reactors, or unsteady operation greatly complicate analysis. For a benchmark, however, a relatively simple system is best.

The simplest version of the bioreactor problem is a continuous flow stirred tank reactor (CFSTR) in which cell growth depends only on the nutrient being fed to the system. The target value to be controlled is the cell mass yield. Often one wants to produce as much cell mass as possible. A basic set of equations for such a bioreactor (Agrawal et al. 1982) is:

$$\frac{dC_1}{dt} = -C_1w + C_1(1 - C_2)e^{C_2/\gamma}$$

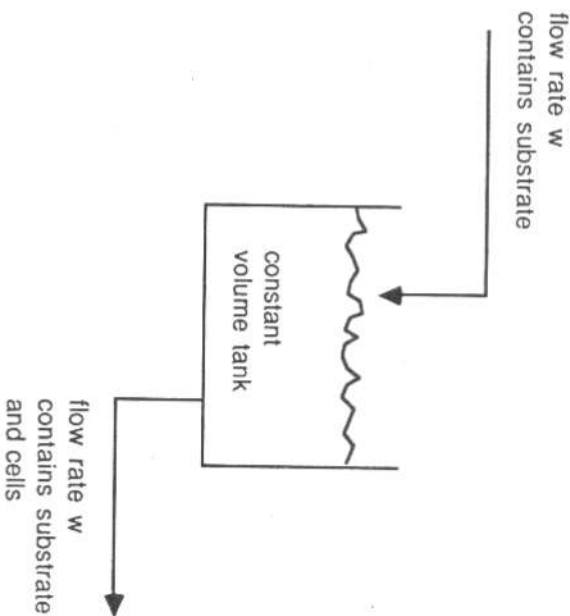

Figure 16.3
Diagram of bioreactor.

$$\frac{dC_2}{dt} = -C_2w + C_1(1 - C_2)e^{C_2/\gamma} \frac{1 + \beta}{1 + \beta - C_2}$$

where C_1 and C_2 are, respectively, dimensionless cell mass and substrate conversion, with C_2 defined as $(S_F - S)/S_F$, where S_F is the concentration of substrate (nutrient) in the feed to the reactor and S is the concentration of substrate in the reactor. (See figure 16.3.) The control parameter, w , is the flow rate through reactor. The first equation says that the rate of change in the amount of cells is equal to the amount of cells carried out of the tank (C_1w) plus the amount by which the cells grow ($C_1(1 - C_2)e^{C_2/\gamma}$). The growth rate is proportional to the current amount of cells (C_1), but depends nonlinearly on the concentration of nutrient (C_2). The second equation says that the change in the amount of nutrient equals the rate at which nutrient is swept out of the system plus the rate at which it is metabolized by the cells. The constants β and γ determine the rate of cell growth and nutrient consumption. The

equational form implies that cells grow fastest at intermediate substrate concentrations and slower at very high or low concentrations. (Note that some researchers define another parameter D_a which is equal to $1/w$ in our formulation.) This is not a completely realistic model of any bioreactor, but it provides a simple but challenging system that has been studied in by process control experts (Agrawal and Seborg 1987, Brengel and Seider 1989.)

This system is difficult to control for several reasons: the uncontrolled equations are highly nonlinear and exhibit limit cycles. Optimal behavior occurs in or near an unstable region. The problem exhibits multiplicity: two different values of the control parameter—flow rate—can lead to the same desired set-point in cell mass yield.

This problem has proved challenging for conventional controllers. A test run with parameter values $\beta = 0.48$ and $\gamma = 0.02$ was made. Note that for these values of β and γ , a Hopf bifurcation occurs at $w = 0.829$. The system was brought to steady state at a flow rate of $w = 0.769$ and then the target cell mass C_1 was increased by 0.05. Control was made at intervals of 0.5 dimensionless time units. The above change in set-point is sufficient to shift from a stable regime into the domain of attraction of the limit cycle. Internal Model Control (IMC) required 26 coefficients to achieve model response within 75 percent of its steady state gain but was unstable due to inaccuracy in the linearized model. Control schemes which assume that the correct model of the bioreactor is known can achieve better success by using predictions of future behavior. However, the quality of control depends critically on having an accurate model. Assuming that the correct equational form is known and using nonadaptive control schemes, small errors in the parameters give rise to very inaccurate control: an error of 2% in γ or 20% in β leads to a 50% error in the target cell mass (Brengel and Seider 1989). Note that these tests assume (unrealistically) that there is no noise in the measurements (e.g. of C_1) and that w actually takes on the exact value that the controller requires.

16.6.1 Control of the Bioreactor Using an Adaptive Network

We have implemented a simple, model-based neural-controller using the architecture by Jordan (1988) described above. (See figure 16.4.) Two multilayer networks are used, one for the model of the plant and the second for the controller. In the results presented below, each network

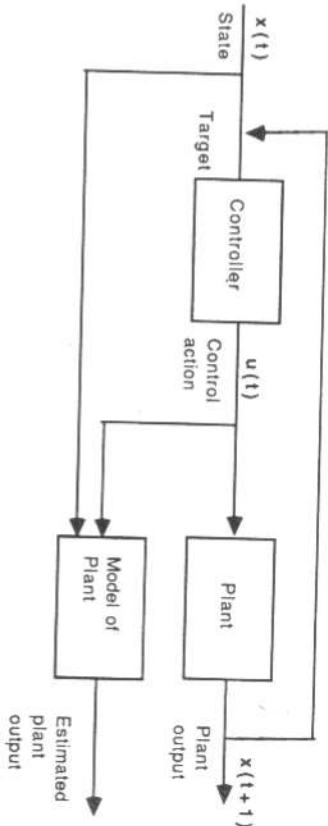

Figure 16.4
Control architecture. Both the controller and the model of the plant are adaptive networks.

has 2 layers of 5 hidden nodes each; more nodes will, of course, give better accuracy.

We trained the adaptive network model using input concentrations and control actions all varying over the full dimensionless range of zero to one. When the controller is attached, trained, and tested on target values of $C_1 = 0.113$ and $C_2 = 0.8902$, the above network (with two sets of five hidden nodes) produces output concentrations of 0.1224 and 0.8778. The discrepancy between the target value and the actual comes from inaccuracies in the model.

We have also tested the network with random noise introduced into the control signal w (Ungar, Powell, and Karnens 1989). The results show the control to be stable and reasonably accurate. To achieve the best control on real, noisy systems will require using networks which have as inputs the outputs from previous times and which attempt to forecast future values.

We suggest that as a benchmark this system be tested on three problems: (1) control about the point $w = 0.75$, which is open-loop stable, (2) control about the point $w = 1.25$, which is unstable, and (3) the change described above starting with $w = 0.769$ (actually $1/1.3$ in the results cited) which corresponds to $C_1 = 0.1236837$ and increasing the target concentration C_1 by 0.05, which crosses the stability boundary.

16.6.2 More Complex Version of the Bioreactor Control Problem

A sequence of problems of increasing difficulty can be constructed based on a system similar to the above bioreactor. The system described above has two outputs and one input. A two-input-two-output problem is easily created by adding a second feed stream with a concentrated substrate (S_c) $S_c \gg S_F$ and flow rate w_c which would be used to raise the substrate concentration. A third feed (flow rate w_3) with no substrate might also be wanted to lower the substrate concentration. This gives a resulting equation set:

$$\frac{dC_1}{dt} = -C_1(w + w_c + w_3) + C_1(1 - C_2)e^{C_2/\gamma}$$

$$\frac{dC_2}{dt} = -C_2(w + w_c + w_3) + c_c w_c + C_1(1 - C_2)e^{C_2/\gamma} \frac{1 + \beta}{1 + \beta - C_2}$$

with c_c representing the dimensionless form of S_c and w, w_c , and w_3 as control parameters. One can now set independent targets for C_1 and C_2 , giving a multivariable control problem.

The above problems are the simplest in a large class of problems. More complex versions of the system occur frequently and are easy to set up; one need only consider the products produced by the cells. These products frequently inhibit further growth, thus increasing the complexity. It is also often desirable to maximize the quantity of one or more of the chemicals produced by cells. Other models of cell behavior including behavior which varies strongly with growth regimes or history also frequently occur. Rather than moving from one steady state to another in a continuous flow reactor, one can look at batch or semibatch problems in which substrate is (periodically) added to the tank, but nothing flows out. In this case one wants to maximize production of cell mass over the course of a batch, and an optimization (delayed reinforcement) problem arises.

Although one would not expect every controller to handle this full range of problems, it is important to know that they are available for testing different aspects of learning. Different control challenges such as nonlinearity, interaction of multiple variables, and optimization over time can be introduced into different problem variations.

16.7 Conclusions

Chemical process control problems offer an ideal test bed for many of the techniques described in the first part of this book. To address the harder control problems, one must address questions of credit assignment (what action was responsible for an observed effect), reasoning about dynamic systems, optimization over time, and incorporation approximate process models. Layered feedforward models with smoothness constraints (Jordan 1988), recurrent networks and reinforcement learning (Williams 1988), and temporal differences (Sutton 1988) all promise major contributions to the area. It will be interesting to see how well some of the architectures which are starting to be used for robotic control problems (Kawato et al. 1988, Miller and Hewes 1988) generalize to chemical process control problems, and what changes are suggested by the different problems.

For adaptive networks to prove their worth in process control, they must be directly compared to conventional controllers—i.e., they must be used to solve the same problems, so that the results can be compared. We have presented a model problem in bioreactor control which has been tackled with limited success by conventional control methods. This problem is easily extended to contain additional well-characterized control difficulties. The next task is now to test the various adaptive network architectures and learning algorithms on this and other benchmarks.

References

- Agrawal, M., and Seborg, D. E. (1987). Self-tuning controllers for nonlinear systems. *Automatica*, 23(2): 209–214.
- Agrawal, P., Lee, C., Lim, H. C., and Ramkrishna D. (1982). Theoretical investigations of dynamic behavior of isothermal continuous stirred tank biological reactors. *Chemical Engineering Science* 37:453.
- Anbunani, K., et al. (1981). Self-tuning minimum-variance control of nonlinear systems of the Hammerstein model. *IEEE Trans. Aut. Control*, 26:959–961.

- Anderson, C. W. (1987). Strategy learning with multilayer connectionist representations. In *Proceedings of the Fourth International Workshop on Machine Learning*, 103-114, Irvine, CA: Morgan Kaufmann.
- Astrom, K. J., et al. (1977). Theory and applications of self-tuning regulators. *Automatica*, 13:457-476.
- Barto, A. G., Sutton, R. S., and Anderson, C. W. (1983). Nonlinearlike elements that can solve difficult learning control problems. *IEEE Transactions on Systems, Man, and Cybernetic*, 13(5):835-846.
- Bhat, M. and McAvoxy, T. J. (1989). Use of neural nets for dynamic modeling and control of chemical process systems. *Computers and Chemical Engineering*, in press.
- Brengel, D. D. and Seider, W. D. (1989). A multi-step nonlinear predictive controller. *Ind. Eng. Chem. Res.*, 28:1812-1822.
- Chang, H-C., and Chen, L-H. (1984). Bifurcation characteristics of nonlinear systems under conventional PI control. *Chemical Engineering Science*, 39(7/8):1127.
- Cutler, C. R., and Ramaker, B. L. (1979). Dynamic matrix control: A computer control algorithm. Paper presented at the AIChE National Meeting, Houston, TX.
- Economou, C. G., and Morari, M. (1986). Internal model control. 5. Extension to nonlinear systems. *Ind. Eng. Chem. Proc. Des. Dev.*, 25:403.
- Garcia, G. E. and Morari, M. (1982). Internal model control. 1. A unifying review and some new results. *Ind. Eng. Chem. Proc. Des. Dev.*, 21:308.
- Jordan, M. I. (1988). Supervised learning and systems with excess degrees of freedom. COINS Technical Report 88-27. Department of Computer Science and Information, University of Massachusetts, Amherst.

- Kawato, M., Uno, Y., Isobe, M., and Suzuki, R. (1988). Hierarchical-neural network model for voluntary movement with application to robotics. *IEEE Control Systems Magazine*, 8:(2) 8-16.
- Lachmann, K. H. (1982). Parameter-adaptive control of a class of nonlinear processes. Proceedings of the 6th IFAC Symp. Ident. Syst. Param. Est. 372-378. Arlington, VA, 372-378.
- Li, W-C. and Biegler, L. T. (1987). Process control strategies for constrained nonlinear systems. *Ind. Eng. Chem. Res.*, 27:1421.
- Michie, D., and Chambers, R. A. (1968). 'Boxes' as a model of pattern formation. In C. H. Waddington, (ed.), *Towards a theoretical biology. Vol. 1, Prolegomena*, 206-215. Edinburgh, Scotland: Edinburgh University Press, 206-215.
- Miller, W. T., and Hewes, R. P. (1988). Real time experiments in neural network based learning control during high speed nonrepetitive robot operations. In *Proceedings of the Third IEEE International Symposium on Intelligent Control*, 24-26, Washington, D.C., August.
- Morari, M., and Zafriou, E. (1989). *Robust process control*. Englewood Cliffs, NJ: Prentice-Hall.
- Shinsky, F. G (1977). *Distillation control for productivity and energy conservation*. New York: McGraw-Hill.
- Sutton, R. S. (1988). Learning to predict by the methods of temporal differences. *Machine Learning*, 3:9-44.
- Svoronos, S., et al. (1981). Filtering and error analysis via the UDU covariance factorization. *IEEE Transactions on Automatic Control*, 23:901.
- Ungar, L. H., Powell, B. A. and Kamens, S. (1990). Adaptive networks for fault diagnosis and process control. *Computers and Chemical Engineering*, in press.

Widrow, B. (1964). A trainable control system: 'The broom balancer.' Standard Electronics Lab Report S4-SEL-64-042, Technical Report 6762-1, App. C, 84, and 85-87.

Williams, R. J. (1988). Toward a theory of reinforcement learning connectionist systems. Technical Report NU-CCS-88-3, Northeastern University, Boston, MA.