

“More-than-Moore”

White Paper

Editors:

Wolfgang Arden
Michel Brillouët
Patrick Coge
Mart Graef
Bert Huizing
Reinhard Mahnkopf

Table of Contents

Executive summary.....	3
Introduction.....	4
Preconditions for an industry-wide technical roadmap	11
Lessons learned from “More Moore”	12
1- Meeting the preconditions for industry-wide roadmapping	12
2- Combining focus and variety.....	13
Proposed methodology for “More-than-Moore”	14
Applying the proposed methodology.....	16
From societal needs to markets.....	16
MtM devices	19
Interacting with the outside world	19
Powering	21
MtM technologies	22
Assessing selected MtM devices and technologies with respect to roadmapping.....	22
Conclusion	25
Appendix A : Definitions.....	27
Appendix B : Combining Focus and Variety : The Photolithography example	30

Executive summary

Since the early 70's, the semiconductor industry ability to follow Moore's law has been the engine of a virtuous cycle: through transistor scaling, one obtains a better performance-to-cost ratio of products, which induces an exponential growth of the semiconductor market. This in turn allows further investments in semiconductor technologies which will fuel further scaling. The ITRS roadmapping effort has assumed the validity of Moore's law and the continuation of this virtuous cycle. Conversely, it can be argued that the roadmap has helped to sustain the virtuous cycle by identifying the knowledge gaps for this trend to continue, and helping to focus the R&D efforts.

The industry is now faced with the increasing importance of a new trend, "More than Moore" (MtM), where added value to devices is provided by incorporating functionalities that do not necessarily scale according to "Moore's Law".

Given the benefits that roadmapping has brought the Semiconductor-industry so far, it is an opportunity for the ITRS community, *i.e.* the Technology Working Groups and the International Roadmap Committee, to include significant parts of the "More-than-Moore" domain in its work.

Traditionally, the ITRS has taken a "technology push" approach for roadmapping "More Moore", assuming the validity of a simple law such as Moore's law. In the absence of such a law, a different methodology is needed to identify and guide roadmap efforts in the MtM-domain.

In this white paper, we therefore propose a methodology that helps the ITRS community to identify those MtM-technologies for which a roadmapping effort is feasible and desirable. This More than Moore roadmapping effort is likely to require the involvement of many actors beyond the ITRS historical membership.

Introduction

The idea of a technology roadmap for semiconductors can be traced back to a paper by Gordon Moore in 1965, in which he stated that the number of components that could be incorporated per integrated circuit would increase exponentially over time¹. This would result in a reduction of the relative manufacturing cost per function, enabling the production of more complex circuits on a single semiconductor substrate. Since 1970, the number of components per chip has doubled every two years. This historical trend has become known as “Moore’s Law”.

The "general purpose nature" of semiconductor technology has widespread impact on many other industries because its considerable productivity growth means the same performance level for substantially less cost during a given year. The economic value of Moore’s Law has been its powerful deflationary force in the world’s macro-economy that results in job creation. Inflation is a measure of price increases without any qualitative change in performance. So, when the price per function is declining, it is deflationary. This long-term deflationary effect of semiconductors has never been fully accounted for in statistics and economics. For example, the decline in price per bit has been stunning. In 1954, five years before the integrated circuit was invented, the average selling price of a transistor was \$5.52. Fifty years later, in 2004, this had dropped to a billionth of a dollar. A year later in 2005 the cost per bit of dynamic random access memory (DRAM) is an astounding one nanodollar (one billionth of a dollar).

As the number of components (*i.e.* transistors, bits) per chip increases, the total chip size has to be contained within practical and affordable limits (typical chip sizes should be $<145 \text{ mm}^2$ for DRAM devices and $<310 \text{ mm}^2$ for microprocessor units (MPUs)). This can be achieved by a continuous downscaling of the critical dimensions in the integrated circuit, which can be expressed in terms of Moore’s Law as a scaling by a factor of 0.7 ($1/\sqrt{2}$) every 2 years, where “critical dimension” is understood as “half pitch”, as defined in the International Technology Roadmap for Semiconductors” (ITRS)².

As a consequence of this trend, the miniaturization of circuits by scaling down the transistor has been the principal driver for the semiconductor technology roadmap, for more than forty years. Thanks to its ability to dramatically decrease the cost per elementary function (e.g., cost per bit for memory devices, or cost per MIPS for computing devices), the semiconductor industry has reached by the year 2000 the \$ 250 billion mark, displacing alternative system solutions (e.g., in telecommunication, radios, TVs...) or enabling the emergence of entirely new markets (PCs).

In a nutshell, the industry ability to follow Moore’s law has been the engine of a virtuous cycle (see Fig.1): through transistor scaling one obtains a better performance to cost ratio of products which induces an exponential growth of the semiconductor market. This in turn allows further investments in new technologies which will fuel further

¹ Moore G.E., “Cramming more Components onto Integrated Circuits”, *Electronics*, 38 (8) (April 19, 1965); reproduced in Proc. IEEE, 86, 82 (1998).

² Semiconductor Industry Association, *The International Technology Roadmap for Semiconductors*, 2009 Edition.

scaling. Technical progress was of course a key ingredient of this industry ability, but it was not the only one: another key factor was the high degree of confidence, shared by the industry players, that achieving Moore's law was possible AND would bring the expected benefits.

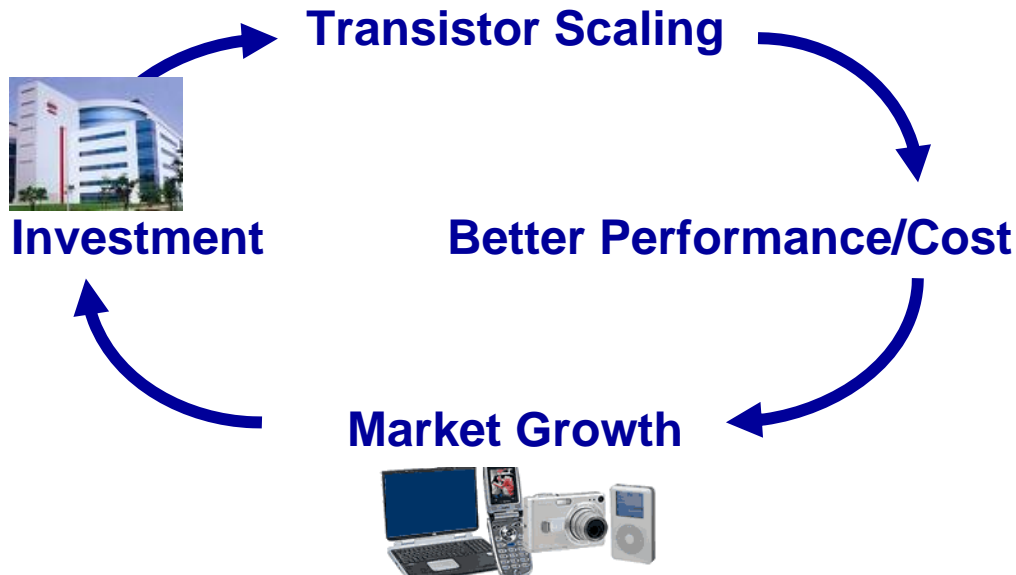

Fig. 1: The virtuous circle of the semiconductor industry

The ITRS is based on this industry-wide shared confidence of both the technical feasibility and the economic validity of this virtuous cycle, as it is clearly stated in the introduction to the ITRS executive summary: “*a basic premise of the Roadmap has been that continued scaling of electronics would further reduce the cost per function [...] and promote market growth for integrated circuits*”.

Of course the ITRS is not the only mechanism that has been at work to achieve that virtuous cycle. Nevertheless, it has had a strong prescriptive effect: not a single PhD thesis in the field is written without positioning its research vs. the ITRS acknowledged “roadblocks”. Likewise, funding agencies are also referring to the roadmap. The ITRS has therefore been able to provide **research guidance** for the many actors of the semiconductor ecosystem (semiconductor companies, equipment and material providers, public and private research laboratories and institutes, and funding agencies), thereby significantly contributing to *technology* exploration and at the same time *increase resource efficiency* in the very fast technological development of the industry. It should also be stressed that the ITRS helped to **synchronize** the technology development and the timely availability of manufacturing equipments and methods.

The literature on innovation management supports this view of the key role of a global roadmapping process for the industry innovation capabilities. This literature stresses that the success of an individual company depends critically on the “*collective health of the organizations that influence the creation and delivery*” of the firm

product³ – in short, the ecosystem of the firm –. It also documents the attempt of individual firms to foster – and not only benefit from – that ecosystem health. The next logical step is a situation where competitors, which in theory could collectively benefit from the same healthy ecosystem, cooperate to sustain that ecosystem. In fact, the Roadmap can be viewed as a common good pursued and collectively managed by the ecosystem players^{4,5} (see also **Table 1**).

<ol style="list-style-type: none"> 1. guide the research effort worldwide 2. synchronize the technology development and the timely availability of manufacturing tools and methods 3. increase the resource efficiency through focus 4. promote market growth and job creation (see footnote 6)

Table 1: *Potential benefits of an industry-wide technical roadmapping effort*⁶

From a technology perspective, the continuous increase in the integration density proposed by Moore’s Law was made possible by a dimensional scaling whose benefits were conceptualized by R. Dennard⁷: in reducing the critical dimensions while keeping the electrical field constant, one obtained at the same time a higher speed and a reduced power consumption of a digital MOS circuit (see **Fig. 2**): these two parameters became driving forces of the microelectronics industry along with the integration density.

³ Iansiti, M. and R. Levien, “Strategy as ecology,” *Harvard Business Review*, March 2004: p. 68-79 (2004).

⁴ Ostrom, E., *Governing the Commons: The Evolution of Institutions for Collective Action*. 1990, New York: Cambridge University Press.

⁵ Moore, J.F., “Business ecosystems and the view from the firm,” *The Antitrust Bulletin*, Vol. 51(1/spring): p. 31-76 (2006).

⁶ In the specific case of the semiconductor industry, it can be argued that growth and job creation benefits go beyond the boundaries of this industrial sector, due to its impact on the efficiency (or even feasibility) of other economic activities

⁷ Dennard R.H.et al., “Design of ion-implanted MOSFETs with very small physical dimensions”, *IEEE J. Solid-State Circ.*, vol.9, p.256 (1974)

Constant field scaling

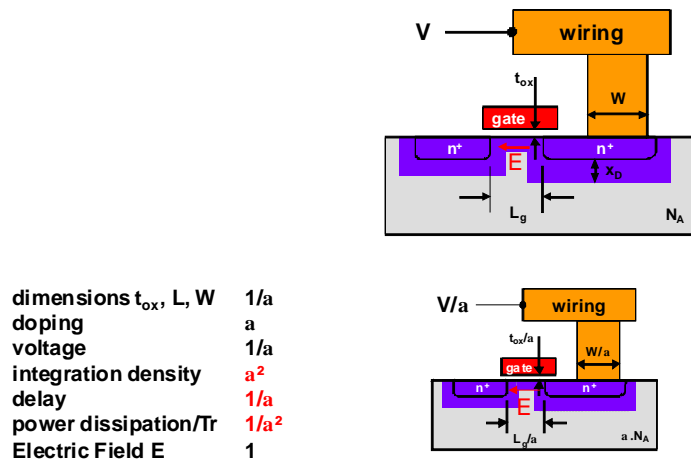

Fig.2 – The constant field scaling theory predicts an increased speed and a lower power consumption of digital MOS circuits when the critical dimensions are scaled down.

The CMOS transistor is the basic building block for logic devices (e.g. MPU), which – along with storage components – represent the digital content of an integrated circuit. However, many microelectronic products will have non-digital functionalities as well, as they should operate in an user environment. The typical embodiment of these more complex products is realized as an assembly of various components (ICs, passive components, etc.) on a printed circuit board (PCB). However, the present progress in both process technology and design is enhancing the compatibility of CMOS and non-digital technologies, which enables the migration of non-digital components from the PCB into the package containing the integrated circuit⁸, or even into the chip itself⁹. This combined need for digital and non-digital functionalities in a product is depicted in **Fig. 3**.

⁸ The resulting implementation is called “System-in-Package” or SiP

⁹ In this case it is referred as a “System-on-Chip” or SoC

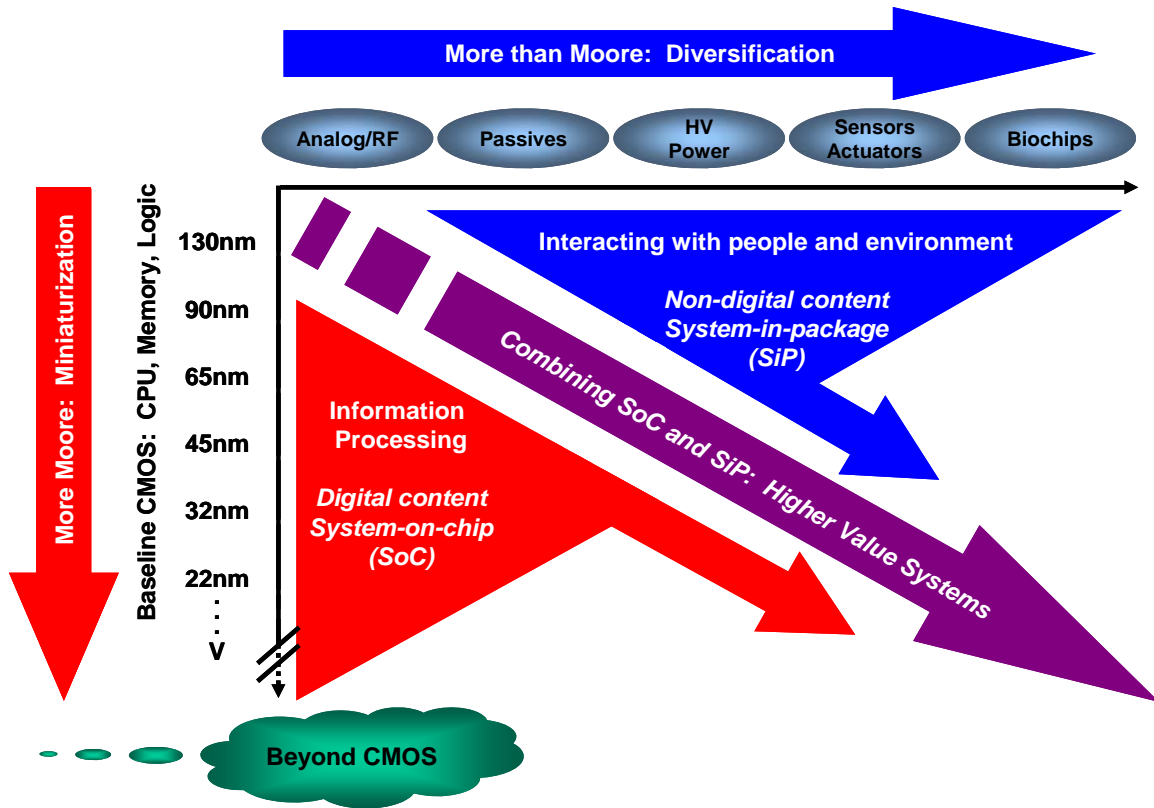

Fig. 3. The combined need for digital and non-digital functionalities in an integrated system is translated as a dual trend in the International Technology Roadmap for Semiconductors: miniaturization of the digital functions (“More Moore”) and functional diversification (“More-than-Moore”).

The International Technology Roadmap for Semiconductors has emphasized in its early editions the “miniaturization” and its associated benefits in terms of performances, the traditional parameters in Moore’s Law. This trend for increased performances will continue, while performance can always be traded against power depending on the individual application, sustained by the incorporation into devices of new materials, and the application of new transistor concepts¹⁰. This direction for further progress is labeled “More Moore”.

The second trend is characterized by functional diversification of semiconductor-based devices. These non-digital functionalities do contribute to the miniaturization of electronic systems, although they do not necessarily scale at the same rate as the one that describes the development of digital functionality. Consequently, in view of added functionality, this trend may be designated “More-than-Moore” (MtM).

¹⁰ Maintaining the increase of performances by other means than just scaling the dimensions is called “equivalent scaling”

Functional diversification may be regarded as a complement of digital signal and data processing in a product (see **Fig. 4**). This includes the interaction with the outside world through an appropriate transduction (sensors and actuators) and the subsystem for powering the product. These functions may imply analog and mixed signal processing, the incorporation of passive components, high-voltage components, micro-mechanical devices, sensors and actuators, and micro-fluidic devices enabling biological functionalities. It should be emphasized that “More-than-Moore” technologies do not constitute an alternative or even competitor to the digital trend as described by Moore’s Law. In fact, it is the heterogeneous integration of digital *and* non-digital functionalities into compact systems that will be the key driver for a wide variety of application fields, such as communication, automotive, environmental control, healthcare, security and entertainment¹¹. Whereas “More Moore” may be viewed as the brain of an intelligent compact system, “More-than-Moore” refers to its capabilities to interact with the outside world and the users.

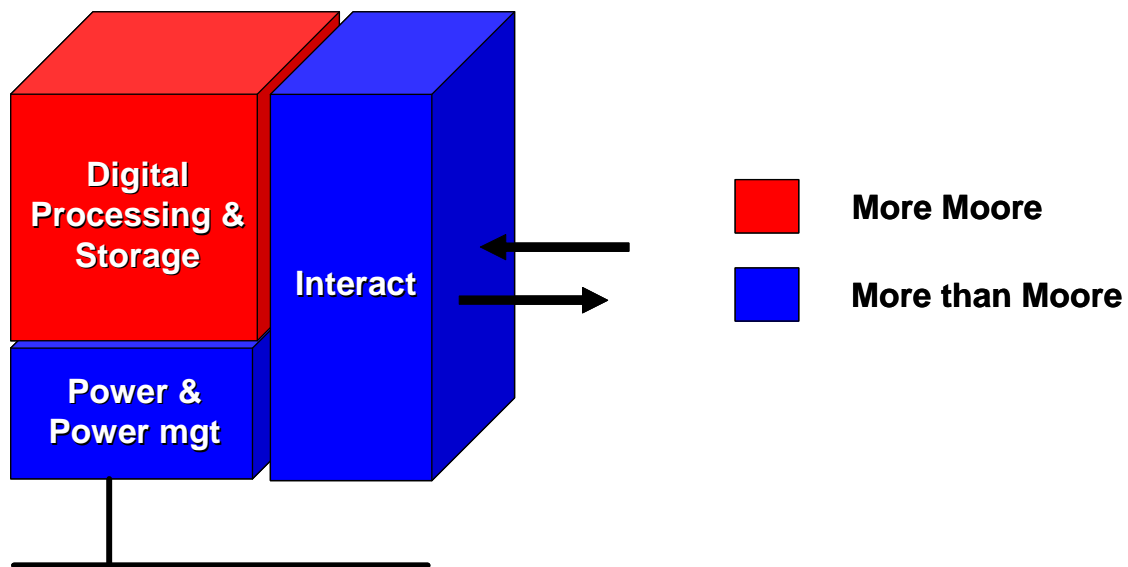

Fig. 4 – “More-than-Moore” devices complement the digital processing and storage elements of an integrated system in allowing the interaction with the outside world and in powering the system.

Figure 5 illustrates this architecture using the imager example: combination of both More Moore (image signal processing) and More than Moore (image sensor, through silicon via) technologies result into a compact camera, including smart and/or (ultra-fast) pixel electronics, and exhibiting low power consumption and small footprint, fit for integration within a portable device such as a mobile phone.

¹¹ European Nanoelectronics Initiative Advisory Council (ENIAC), *Strategic Research Agenda, 2007 Edition*.

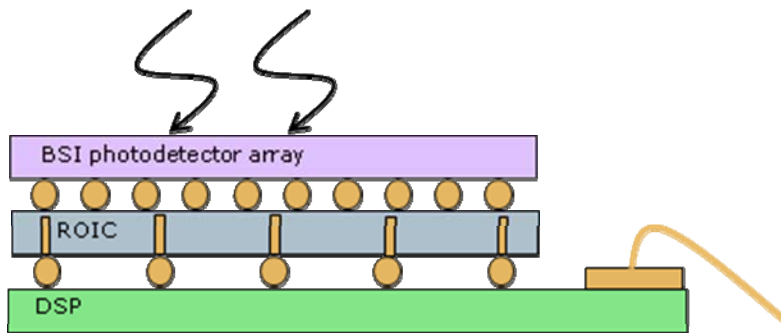

Fig. 5 – 3D integration of a “More-than-Moore” photodetector with “More Moore” read-out and digital signal processing ICs (courtesy of Piet de Moor, IMEC)

“More-than-Moore” based technologies have already made a considerable contribution to the world wide microelectronics market, and the opportunities are huge. Since it is expected that the relative weight of the “More-than-Moore” component in the industry evolution will increase over time, a new “virtuous cycle” must be established to relay the industry expansion, based no longer just on device scaling but on many innovations, at the system, technology, device and circuit levels. Those innovations will have to address not just frontend technologies but backend/packaging technologies as well recognizing an increasing importance of the interaction between frontend and backend technologies for SoC and SiP systems.(see **Fig. 6**).

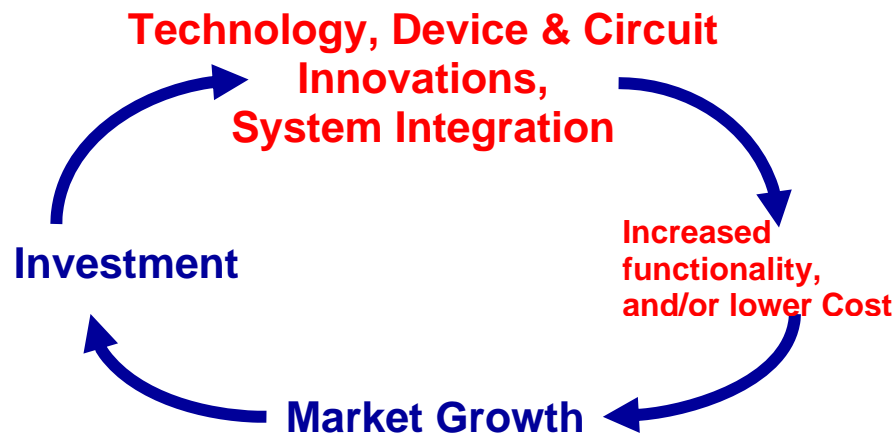

Fig. 6. The virtuous circle which made the success of the digital microelectronic industry should be extended to include the contribution of “More-than-Moore” technologies (Adapted from Prof. Tsu-Jae King-Liu, UC Berkeley)

While opportunities are huge, so are the challenges. The pervasion of “More-than-Moore” technologies will impact the development of integration platforms, of innovative technologies (e.g. for 3D integration of multiple chips), manufacturing techniques (e.g.

for test and reliability assessment of compact systems), and design & modeling tools capable of handling multifunctional heterogeneous subsystems.

This leads to a growing diversity of the scientific fields that must be covered by multidisciplinary research programs in order to sustain the pace of innovation, while the financial constraints are becoming more limited. The question of providing guidance to the research efforts in this new field is therefore crucial. Given the benefits of the roadmapping process experienced in the “More Moore” domain, it seems highly desirable to develop and sustain a similar process in the “More-than-Moore” domain.

It is an opportunity for the ITRS community, *i.e.* the Technology Working Groups and the International Roadmap Committee, to extend its technology roadmap in including part of the “More-than-Moore” domain, in conjunction with the digital domain which will continue in compliance with Moore’s Law. The purpose of this white paper is to analyze the conditions that made the “More Moore” roadmapping possible, and to deduce from that whether a similar roadmapping exercise is feasible for selected “More-than-Moore” domains, and, if yes, derive some indications on how to develop such a roadmap.

Preconditions for an industry-wide technical roadmap

In spite of the advantages listed previously of developing and managing a roadmap as a common good for the industry, it seems that the ITRS is a fairly unique industry-wide roadmapping exercise. This might be due to the set of conditions that must be met to make an industry-wide roadmapping effort possible (see **Table 2**):

First of all, it must be possible to abstract some generic feature which characterizes the progress in the underlying technology: this has to be through a restricted set of figures of merits (**FOM: Figures Of Merit**) whose value continuously increases or decreases over a long period of time. One of the difficulties faced today in the “More-than-Moore” domain is the multiplicity of such figures of merit. The increase in performances of an image sensor, for example, is not judged according to the same criteria than a BAW filter! Once these figures of merit have been identified, a consensus on the methods by which to measure them needs to be achieved and translated into appropriate standards.

Secondly, there must be a convergence of opinion among a majority of the key players on the technical trends of the selected figures of merit, in other words, there must be an agreement on the law of progress that these figures are expected to follow (**LEP: Law of Expected Progress**). This is easier if these trends are not directly linked to a specific application in which the technology will be used or for which the technology will be developed. If the old idea referred as “MEMS Law”¹² (“one product = one process”) applies it may be difficult to come to a common description of the technical trends for the future.

Third, the potential market for a technology for which one wants to build a roadmap must be large enough to justify a pre-competitive joint effort (**WAT: Wide Applicability of the Technology**). The expected profits must be sufficient to support a critical mass

¹² “one product = one process” meaning that each product needs a dedicated development of a unique technology. It should be stressed that the MEMS industry strives to develop generic technologies.

effort devoted to roadmapping a given area of the “More than Moore” domain with a reasonable probability of being successful.

Fourth, the different players in a given technology must be convinced that they will gain, rather than lose, in sharing their vision of the technical development of a given technology and in participating in the roadmapping process (**SHR: willingness to SHaRe**).

Finally, it might be that a given technology has a large potential market, but that there is no constituted industrial community that recognizes that market (this might be the case when a technology addresses disjoint markets, the actors of which do not know each other, or when actors not knowing each other would have to come together to realize the full potential of the technology by creating a new “value chain”). A prerequisite for a roadmapping effort is therefore the existence of a community (**ECO: Existing COmmunity**).

- | |
|--|
| <ol style="list-style-type: none"> 1. restricted set of figures of merits (FOM) 2. convergence of opinion among a majority of the key players on the progress trends that these figures of merit are expected to follow (LEP) 3. potential market of significant size inducing a wide applicability of the roadmap (WAT) 4. willingness to share information (SHR) 5. existence of a community of players (ECO) |
|--|

Table 2: Necessary conditions for an industry-wide technical roadmap effort

Lessons learned from “More Moore”

1- Meeting the preconditions for industry-wide roadmapping

The CMOS planar technology has given birth to an industry and clearly meets the preconditions listed above:

- **FOM:** in fact, one might argue that there is only one figure of merit, at least in the digital domain: the achievable transistor density (sometimes summed up through the transistor gate length, or the metal 1 or poly half pitch) which has doubled every two to three years since the seventies and is expected to continue along that trend over the next decade. In the constant field scaling paradigm, not only a smaller transistor meant lower cost (due to a smaller silicon area for a given function), but it also meant higher performance and lower power per device (see **Fig. 2**).
- **LEP:** Obviously there has been – and still is – a large agreement among the expert community that this figure of merit was expected to follow Moore’s law.

– **WAT:** through the pervasion of the digital information processing which was enabled by the CMOS technology and its cost effectiveness, many markets were covered by the same technological trend, independently of the applications, meeting the precondition of wide applicability of the technology.

The combination of the two previous criteria played a critical role in the roadmap success; since technical and financial decision makers shared confidence that progress would continue (LEP), and thanks to WAT, high returns were expected and thus significant investments were done, in R&D to make the expected progress happen.

- **SHR:** The performance benefit resulting from scaling also allowed solving the issue of competition: all semiconductor companies involved in ITRS could agree on a common target for the evolution of the technological characteristics, namely a constant “shrinking” of semiconductors dimensions; but they maintained competition on the *use* of the “shrinking” capacity to develop “shrunk” products. Hence the “shrinking” principle is a “decoupling” principle between common interest and competition. Finally, since the roadmap was defining which performances were to be reached over the years (e.g., the value of the dielectric constant for the gate oxide), but not how to achieve it (detailed process step recipes and process flows remain trade secrets for technology providers), competitive issues were avoided.

- **ECO:** The ITRS effort was first initiated at the US level as the NTRS, which in turn can be considered as a child of the 1985 SRC summer study, which was intending to “construct a roadmap which would help to secure [...] the future of the US semiconductor industry”¹³. So there was, as early as 1985, an industrial community sharing a collective conscience of its existence.

2- Combining focus and variety

As mentioned earlier, one goal of the ITRS is to provide research guidance for the semiconductor ecosystem, and it has achieved a strong prescriptive effect. This has had a very effective focusing effect for the scarce research resources. The question is: wasn't this achieved at the expense of innovative ideas?

However, in fact, the ITRS managed to combine focus and variety. This point can be illustrated by taking the example of the various venues followed by the industry so far, and the ones listed as possible solutions, in the photolithography domain (see **Appendix B** for a detailed discussion).

So, far from quenching innovative ideas, the semiconductor industry roadmapping in the “More Moore” direction has managed to focus resources while leaving ample room for disruptive concepts. Whatever methodology is applied in the “More-than-Moore” domain will need to allow for the same balance.

¹³ Larry Sumney, SRC President, cited by Schaller, Robert R. - “Technological Innovation in the Semiconductor Industry : A case study of the International Technology Roadmap for Semiconductors (ITRS).”, PhD dissertation, George Mason University, 2004

Proposed methodology for “More-than-Moore”

In this chapter a methodology will be described for encompassing “More-than-Moore” technologies in the ITRS roadmap in the future.

This methodology is somewhat different from what we are used to in past and present ITRS roadmap releases for “More Moore” technologies. The reason for this is the following: the future development of “More Moore” technologies can be quite accurately described with high confidence level by extrapolating Moore's law from trends observed in the past based on the availability and commercialization of products in those technologies in the recent years. Scaling requirements can be derived from extrapolating those trends into the future. This doesn't require visions of future markets and applications, the underlying technologies are "transparent" to applications and products to a large extent and have a broad spectrum of applicability for many market segments.

This is different for MtM technologies: There is no "natural" roadmap existing per se, technology needs and company internal roadmaps are usually defined based on short term market requirements. In addition there is a much closer link between process technologies on the one hand and product implementations on the other hand. The following methodology for deriving roadmaps for MtM technologies is thus proposed:

Based on societal needs and market trends visible today and based on visions for future markets and products some *application scenarii* are sketched. For those different scenarii required *functionalities* and *related devices* are derived. Technology building blocks are then analyzed and described based on a restricted *set of parameters*. The expectation is that those technology building blocks will – to a large extent – not depend on the scenario, or in other words: many different scenarios will hopefully lead to same or similar technology building blocks: as done in the “More Moore” arena, *requirements* on these building blocks will be derived from the needs of the most demanding applications. In other words the identified building blocks should enable functionalities which are enabling several applications and markets. They should be "robust" or versatile enough against potential scenario changes.

In the "home of the future" smart solutions will be required with energy efficient intelligent subsystems for all kind of appliances. In the automotive industry the efficiency of power trains needs to be improved, driving forces are pollution and fuel consumption reduction. There is a need for high voltage capabilities in power management, power conversion and power distribution in general. Power management and power handling will enable operation of CMOS low voltage circuitry from battery or AC power line in a wide range of consumer products as well (ENIAC SRA 2007). Those scenarii will require innovation in power electronics and will drive technical requirements for the underlying high voltage and power technologies. It should be possible to derive technology requirements for key parameters on technology module level like target specifications for e.g. on-state resistance R_{on} of the respective transistors to reduce power losses. The remaining task to be performed during the roadmapping procedure is the timing by when those specifications are expected to be met over time.

This methodology should lower the barriers for all stakeholders in the process to openly share information during the roadmap discussions to come up to a commonly accepted MtM roadmap.

On top of it, we may notice that independently of which of the two markets (electrical vehicle or “home of the future”) takes off, the roadmap for underlying high voltage and power technologies would not be dramatically impacted, thus exhibiting robustness vs. scenario changes.

The MtM building blocks which would be amenable for inclusion within ITRS should be selected through the following process:

- 1) assess the technologies with respect to the prerequisites for a successful technical roadmapping, namely:
 - a. technically describe the technologies with a restricted set of parameters or Figures-Of-Merit (FOM)
 - b. consider the technologies sharing a common understanding and convergence of opinions in the semiconductor community on the law of expected progress (LEP)
 - c. define precompetitive domains where contributing parties are willing to share the respective information (SHR)
 - d. identify those technologies with large enough market size which justifies deriving a roadmap (WAT)
 - e. check whether the potential providers of those technologies know each other well enough to engage in a cooperative roadmapping effort (ECO)
- 2) identify those MtM technologies and devices which are already covered by the ITRS or other publicly available roadmaps
- 3) identify major MtM-specific processes, tools and methods which should be considered by the related ITRS technology TWGs¹⁴

¹⁴ MtM topics which are outside of any scope of the present TWGs, could require the creation of a new TWG, or a specific cross-functional coordination of existing TWGs.

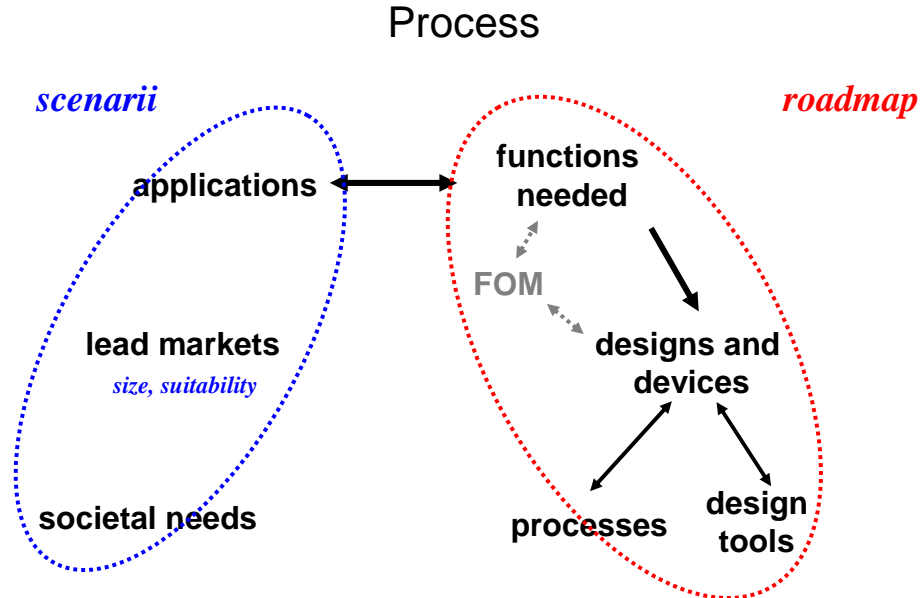

Fig. 7. In order to identify relevant MtM devices and technologies to be roadmapped, one may start in looking for suitable markets and applications, derive then underlying functionalities and devices. A set of associated parameters and processes will be derived

Applying the proposed methodology

From societal needs to markets

Underlying the evolution of markets and applications, and therefore their economic potential, is their potential in addressing societal trends and challenges for the next decades. Societal trends can be grouped as health & wellness, transport & mobility, security & safety, energy & environment, communication and e-society (this latter term including infotainment). Many other names may be used but all cover more or less the same fields. These trends create significant opportunities in the markets of consumer electronics, automotive electronics, medical applications, communication, etc. Examples of applications linking societal trends and markets are given in the figure below (**Fig. 8**).

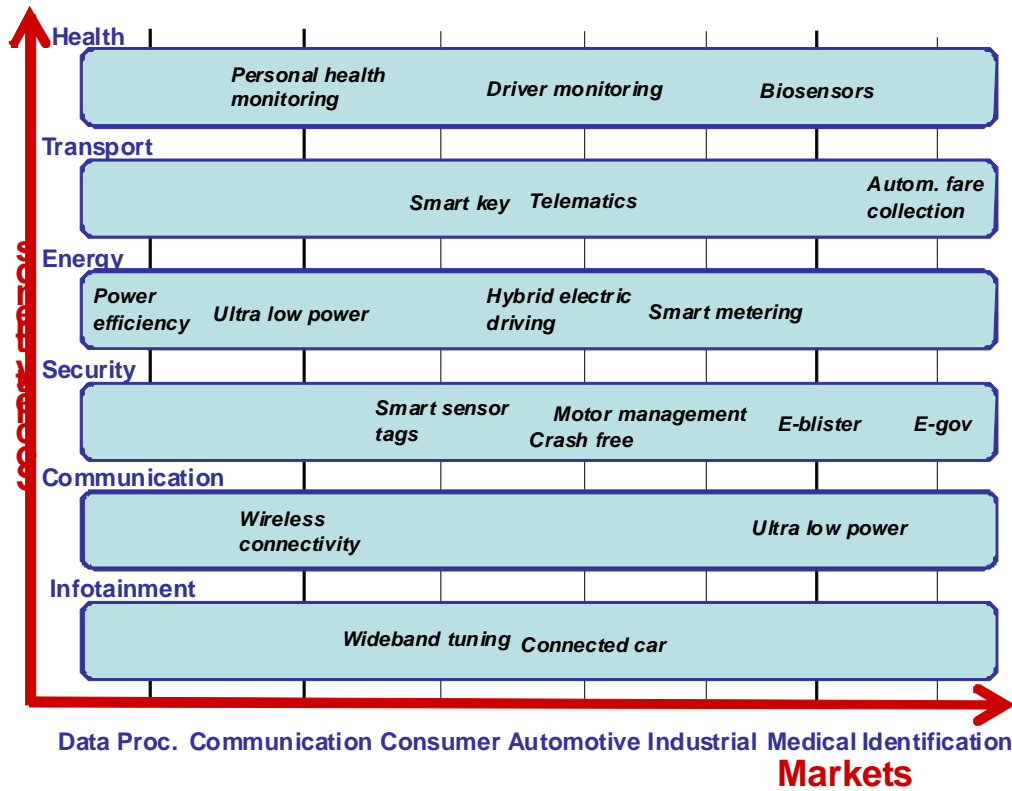

Fig. 8. Example of an application matrix linking societal needs and market segments.

Note that the above figure is somewhat simplifying things : for example, “connected car” is relevant to many trends beyond e-society, e.g.:

1. cars synchronizing their speed can act as virtual “train on the roads”, reducing energy consumption;
2. communication with traffic lights could increase safety;
3. the car-to-car links could be used by ad-hoc communication networks

Another way of linking societal needs and markets (or systems) is to look at the entire “food chain” from production to consumption for a given good (in the most general sense : for example, entertainment, or travel). Figure 9 below is illustrating this chain for power.

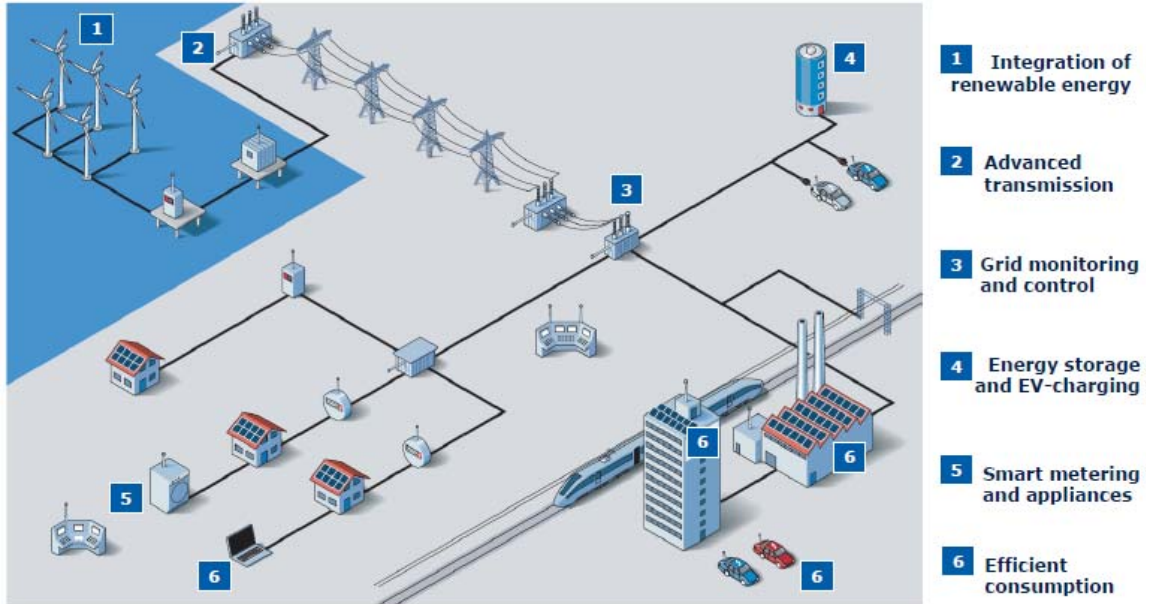

Fig. 9. Entire energy “food chain” from generation via distribution to consumption, in all segments semiconductor power technology devices are required (source: Infineon)

Many applications will target an increase of the functionality of existing functions, e.g. cars will become even more intelligent and further enhance comfort and safety of driver and passengers. Other applications will open new or non-existing markets, e.g. bio-medical chips may well revolutionize health care. A commonality however, is that applications in these markets become increasingly sophisticated and often demand optimized and tailored solutions which will be able to sense and actuate, store and manipulate data, and transmit information.

As sketched in the following figure (**Fig. 10**), some domains tend to be more digital-intensive or require more MtM technologies.



Fig. 10. Some societal needs favor the digital domain (“More Moore”) or the interaction with the outside world (“More-than-Moore”). (from T. Claasen, MEDEA+ Forum, 2007).

MtM devices

Interacting with the outside world

As the digital information processing is expected to use electrons for the years to come the elementary MtM components will have to transduce a physical signal into an electrical signal or vice versa.

Many physical parameters can be considered. However for the sake of simplicity, we list here some illustrative examples of inputs / outputs to the system:

1. **electromagnetic** wave distinguishing:
 - a. the radio-frequency domain up to the THz range
 - b. the “optical” domain from the infrared to the near ultraviolet

- c. the “hard” radiation (EUV, X-ray, γ -ray)¹⁵
2. **mechanical** parameters (position, speed, acceleration, rotation, pressure, stress, etc.) for which MEMS (and more recently NEMS) are the emblematic MtM devices
 3. **chemical** composition
 4. **biological** parameters¹⁶

This list is by no means limitative and will be most likely expanded in the future. It should be also stressed that a given parameter can be expressed:

- as a single measure (sensing) or action (actuation)
- as a **two dimensional** representation (e.g. image sensor for sensing or display for actuation)
- in including a **temporal** component (e.g. as a movie for an image evolving over time)
- more generally in a **multidimensional** approach (e.g. imaging multiple parameters of a single object in 3D dimensions over time)

This further segmentation can induce specific characteristics of the MtM device and technology under consideration.

The following table (**Table 3**) summarizes the proposed taxonomy of MtM devices providing an interaction between the digital domain of the integrated device and the outside world. It gives also some examples of relevant devices.

¹⁵ The cross-over between the optical domain and the hard radiation (ca. $\lambda = 0.1 \mu\text{m}$) can be loosely defined as the wavelength at which no refractive material exist for deflecting the electromagnetic wave.

¹⁶ There may be some overlaps between chemical and biological MtM devices. The present differentiation resides in the sample to be analyzed or to be acted upon: biological transducers are interacting with living objects while chemical transducers are with inert species.

Physical parameter	# dim.	Sensing	Actuating
electromagnetic rf (up to THz) optical incoherent coherent “hard” radiations	1	filter, demodulator, antenna	modulator, antenna
		photodiode	LED laser
		photon counter	
mechanical		MEMS, NEMS	MEMS
chemical		electrical nose	
biological		DNA chip, glucose meter	pacemaker, brain-computer interface
e.g. optical...	2	image sensor	micro-display
	2 + t		
	3		
	n		

Table 3. Potential taxonomy of MtM devices and technologies for sensing/actuating.

Powering

All systems need to be powered in order to perform some information processing. It does translate into the fact that many dedicated components need to be developed and integrated in order to:

- condition the energy or power supply in an usable form for the electronic circuit (e.g. dc-dc or ac-dc conversion)
- scavenge any outside source of energy or power for supplying or complementing the supply of the integrated system, especially in the case of nomadic or autonomous systems
- store energy (e.g. capacitors) which is critical in case of intermittent energy or power supply
- possibly supply energy or power through sources integrated in the SoC or SiP (e.g. micro-battery or integrated fuel cell)

To avoid any misunderstanding, low-power design techniques and low-power digital components are not considered as MtM technologies and devices, although More than Moore devices are very often found in systems that will require low power “More Moore” components.

MtM technologies

By “MtM technologies” we mean generic technologies which do fulfill a specific function such as transducing a physical signal into an electrical one, but enable these functions, or combination thereof, allowing heterogeneous integration.

Assessing selected MtM devices and technologies with respect to roadmapping

The next step would be to assess the MtM technologies described in the previous paragraph with respect to their potential for roadmapping. The following figure is an example of what could be the outcome of such an exercise. It should however be stressed that it is not the intent of this White Paper to perform such an analysis, but rather to demonstrate the methodology which could be applied.

Example of technology building block evaluation

<i>draft</i>	FOM	LEP	SHR	WAT	ECO	In ITRS today?
RF	++	++	+	+ / ++	+	Yes
Power	+	+	?	=	?	No
Imaging	+	+	?	=	?	No
Sensors / actuators	--	?	?	++	--	No
Biochips	--	?	--	?	--	No
...						

FOM = Figure Of Merit; LEP = Law of Expected Progress
 SHR = Willingness to SHaRe ; WAT = Wide Applicability of Technology
 ECO = Existing Community

Table 4. Example of a hypothetical matrix assessing the potential of some MtM devices for roadmapping.

As indicated in Table 4, the “Radio Frequency and Analog-Mixed Signal Technologies for Wireless Communications” TWG has been roadmapping many devices in the RF space since its inception, in effect pioneering the methodology delineated in this white paper, and its excellent work should be recognized here.

It should be stressed that this table is very preliminary and is here only to show the structure. Filling it in will require further work, in particular:

- first to make the link between markets and devices, which is established by the functions required by the markets and that the devices fulfill,
- then to assess, for each device under consideration, the consequences of those links on the values for this device of the parameters characterizing its potential for roadmapping.

The first step can be visualized in the following figure (**Fig. 11**)

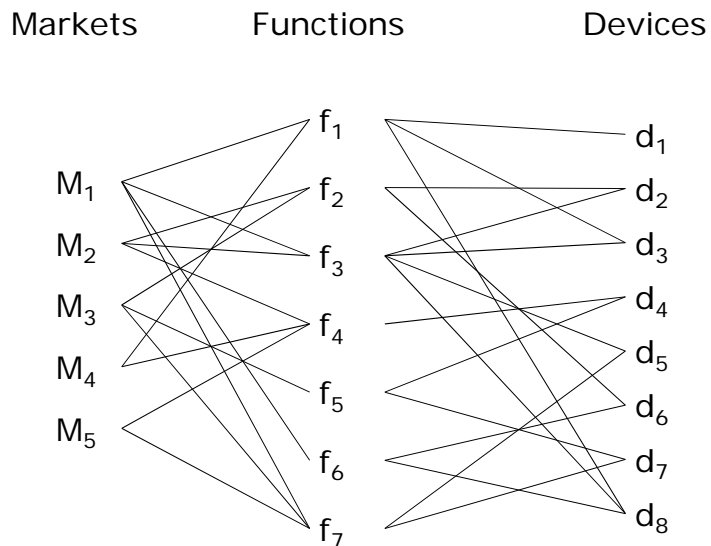

Fig. 11 Relationship between markets and relevant devices.

This diagram will be established by looking at the various markets segments and sub-segments identified in the previous steps, notably while building the application matrix represented in figure 8 : data processing, communication, consumer, automotive, industrial, medical, identification. The list is of course not exhaustive.

For example, electronic modules addressing automotive electronics systems could be segmented into the following major categories (again, this is an example, and needs to be further refined):

- Powertrain Electronics, such as engine controllers, transmission controllers, voltage regulators, and any other systems that control the engine or driveline of the vehicle
- Entertainment Electronics, ranging from standard AM/FM radios to on-board video entertainment systems, satellite radio receivers
- Safety and Convenience Systems, such as airbag sensors, climate controls, security and access controls, anti-lock braking systems

- Vehicle and Body Controls that manage specific vehicle functions, such as suspension, traction, power steering
- In-Cabin Information Systems, such as instrument clusters, trip computers, telematic products
- Non-Embedded Sensors, such as speed sensors, temperature sensors, fluid level sensors, and many others

In turn, any of the functions listed above can be further decomposed into the devices required to fulfill that function (e.g., Gas / Chemical sensors for in-cabin air quality, monitoring exhaust gas composition and oil quality)

The instantiation of the diagram represented in figure 11 will evolve over time, as new markets are considered. However, an exhaustive list is fortunately not required to start the roadmapping process. Quite likely, with only a few markets, devices common to several markets, or crucial for the development of an important market, will rapidly be identified. The next step will be to assess the potential for roadmapping of the various devices which will emerge from the diagram.

In figure 11, device d_1 is required for function f_1 , which is required by markets M_1 and M_4 . If market M_1 and M_4 rely on similar evolution trends for the performances of function f_1 , then this function performance trend will lead to a convergence on the d_1 device law of expected progress (LOP), and define the figures of merit by which this device should be measured (FOM). Knowledge of markets M_1 and M_4 also allow to estimate the readiness to share (SHR) of the market actors, and the existence of a community between these actors (ECO). Finally, the device or technology applicability (WAT) will depend on the predictable evolution of markets M_1 and M_4 , the pervasion of function f_1 in these two markets, and the number of devices d_1 required to fulfill function f_1 .

In general, if function f_j requires d_{ij} devices d_i , and market M_k requires f_{jk} implementations of function f_j , the estimated number of devices d_i required over all markets will be

$$N(d_i) = \sum_k \sum_j f_{jk} \cdot d_{ij}$$

f_{jk} depends on the size of market M_k and will vary over time. Furthermore, since it is a forecast, rather than taking a single number for a given year, the methodology will be more robust if different scenarios are established. If the applicability of a device proves to be large across a variety of scenarios, it can be awarded a high mark for the WAT criteria. For our purpose, exact numbers are not needed: Fuzzy estimates (“very large”, “fairly low”) will be quite enough to determine whether a given device or technology is a good candidate for roadmapping, based on the criteria identified earlier.

For example, we can estimate that high speed bipolar devices will be required to build millimeter wave imaging systems, which in turn can appear in many markets: industrial (production control), health (medical imaging), transportation (obstacle detection), security. It is likely that in many combinations of the possible evolution scenario for these various markets, the applicability of this technology will be wide.

It should be outlined that in the previous example only devices were considered. The supporting processes and techniques need also to be addressed. As an example, looking at MEMS devices one may expect that deep RIE and release processes will play a significant and specific role, while dedicated considerations have to be made regarding design techniques, modeling, test, manufacturing techniques and the like. Likewise, nanoscale contacts and interconnects will represent significant challenges for the MtM domain.

In addition, as represented by figure 4, in most cases More than Moore devices will complement the More Moore trends. Technical enablers will be needed to allow the integration between the More than Moore and the More Moore devices, and roadmaps for these technical devices will also be needed: for example, TSVs, stacking methods, wafer bonding methods, RF signal transmission methods for xxGb/s, optical IO to reach Tb/s data rates, power dissipation methods and other technical enablers.

It is also important to identify domains where it may be more efficient to rely on existing roadmaps rather than to have the ITRS community duplicating this effort. ITRS has a strong interaction with iNEMI for the system drivers. In the same way it may not be appropriate to develop a specific effort where publicly available roadmaps exist¹⁷.

Finally, it should be mentioned that building this link between societal needs, markets and technologies goes well beyond the ITRS current practice, and is likely to require the involvement of many actors beyond the ITRS historical membership. For example, roadmapping efforts in healthcare for clinical and commercial success will require the inclusion of physicians, clinicians, and health regulators from the beginning.

Conclusion

ITRS is very successful in roadmapping the digital domain of the microelectronics, offering guidance to the microelectronic ecosystem, and allowing synchronization between the technological progress and the timely availability of manufacturing techniques. It is expected that the non-digital / non-memory part of integrated systems will play an increasing role in the future putting more emphasis on the MtM domain. The challenge of the microelectronic community is to assess to which extend the success of the ITRS roadmapping effort can be extended further to the MtM technologies.

¹⁷ As an example in the last decade at least three roadmaps were published in Europe addressing the optoelectronic field each of these roadmaps having a dedicated perspective. MELARI published a roadmap in the late 90's (available at <http://cordis.europa.eu/esprit/src/melop-rm.htm>), the European Technology Platform PHOTONICS21 published a Strategic Research Agenda in 2006 (<http://www.photonics21.org/downloads.php>), while the European project MONA published a roadmap looking more specifically on the impact of nanotechnologies in the optical field in 2009 (http://www.ist-mona.org/pdf/MONA_v15_190308.pdf).

It could be an opportunity for the ITRS community, *i.e.* the Technology Working Groups and the International Roadmap Committee, to include more significant parts of the “More-than-Moore” domain. The purpose of this White Paper was to analyze the conditions that made the “More Moore” roadmapping possible, and to deduce from that whether a similar roadmapping exercise is feasible for selected “More-than-Moore” domains, and, if yes, derive some indications on how to develop such a roadmap.

Appendix A : Definitions

Moore's Law

ITRS 2009 Glossary:

An historical observation by Gordon Moore, that the market demand (and semiconductor industry response) for functionality per chip (bits, transistors) doubles every 1.5 to 2 years. He also observed that MPU performance [clock frequency (MHz) × instructions per clock = millions of instructions per second (MIPS)] also doubles every 1.5 to 2 years. Although viewed by some as a “self-fulfilling” prophecy, “Moore’s Law” has been a consistent macro trend and key indicator of successful leading-edge semiconductor products and companies for the past 30 years.

“More Moore”: Scaling

Short definition:

Continued shrinking of physical feature sizes of the *digital* functionalities (logic and memory storage) in order to improve *density* (cost per function reduction) and *performance* (speed, power).

ITRS 2009 Glossary:

- a. Geometrical (constant field) Scaling refers to the continued shrinking of horizontal and vertical physical feature sizes of the on-chip logic and memory storage functions in order to improve density (cost per function reduction) and performance (speed, power) and reliability values to the applications and end customers.
- b. Equivalent Scaling which occurs in conjunction with, and also enables, continued Geometrical Scaling, refers to 3-dimensional device structure (“Design Factor”) Improvements plus other non-geometrical process techniques and new materials that affect the electrical performance of the chip.

“More-than Moore”: Functional diversification

Short definition:

Incorporation into devices of functionalities that do not necessarily scale according to “Moore's Law”, but provide additional value in different ways. The “More-than-Moore” approach allows for the *non-digital functionalities* to migrate from the system board-level into the package (SiP) or onto the chip (SoC).

Proposal ITRS 2009/2010:

Functional Diversification refers to the incorporation into devices of functionalities that do not necessarily scale according to “Moore's Law,” but provide additional value to the end customer in different ways. The “More-than-Moore” approach typically allows for the non-digital functionalities (e.g., RF communication, power control, passive components, sensors, actuators) to migrate from the system board level into a particular

package-level (SiP) or chip-level (SoC) implementation. In addition, the increasingly intimate integration of complex embedded software into SoCs and SiPs means that software might also need to become a fabric under consideration that directly affects performance scaling. The objective of “More-than-Moore” is to extend the use of the silicon-based technology developed in the microelectronics industry to provide new, non-digital functionalities. It often leverages the scaling capabilities derived from the “More Moore” developments to incorporate digital and non-digital functionality into compact systems.

System-on-Chip (SoC)

Wikipedia definition:

System-on-a-chip or system on chip (SoC or SOC) refers to integrating all components of a computer or other electronic system into a single integrated circuit (chip). It may contain digital, analog, mixed-signal, and often radio-frequency functions – all on one. A typical application is in the area of embedded systems.

[<http://en.wikipedia.org/wiki/System-on-a-chip>]

Comment:

In the MtM WP we may want to emphasize that “a single integrated circuit” is in fact monolithic (single die) and that, consequently, all components (functions) have to be manufactured in a single (CMOS-compatible) process technology.

System-in-package (SiP)

System in Package (SiP) is a combination of multiple active electronic components of different functionality, assembled in a single unit that provides multiple functions associated with a system or sub-system. A SiP may optionally contain passives, MEMS, optical components and other packages and devices.

*[Definition from **The next Step in Assembly and Packaging: System Level Integration in the package (SiP)**, White Paper ITRS 2008]*

Heterogeneous integration

Functional combination of dissimilar (electrical, optical, thermal, magnetic, mechanical) components onto a silicon substrate, encapsulated within a single package. The domain covered by the term “heterogeneous integration” is schematically depicted by the light blue triangle in the diagram below.

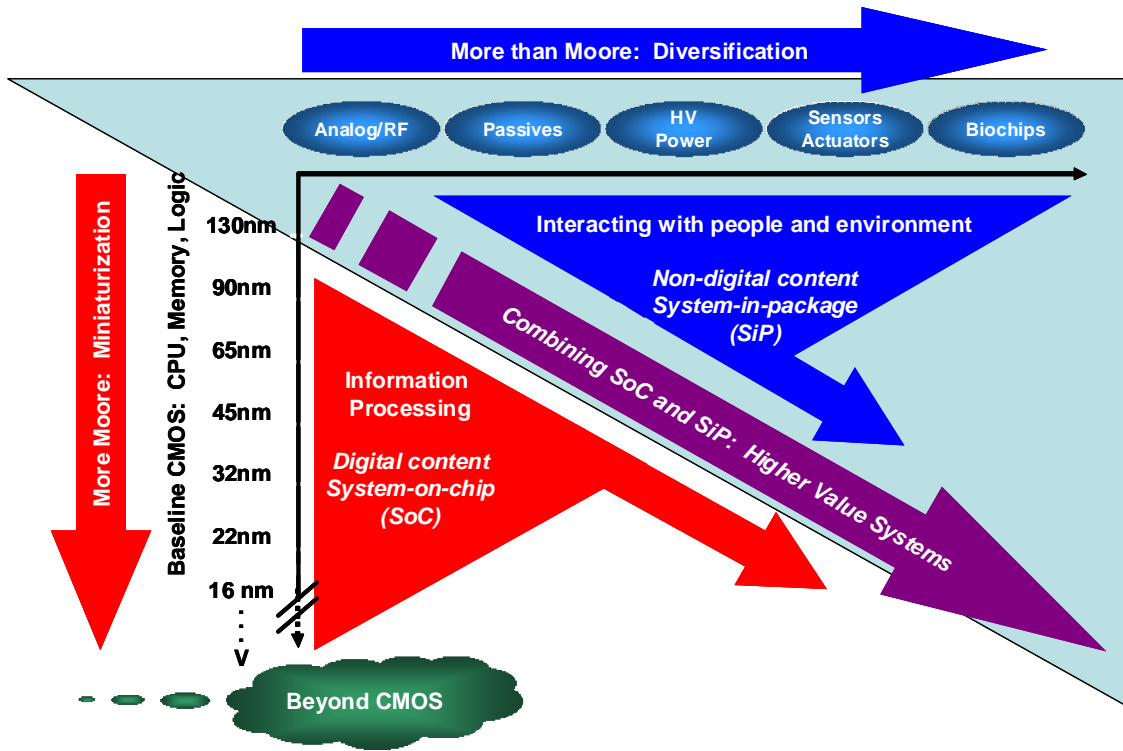

Fig 11. The “hereogeneous integration” domain (light blue triangle).

Appendix B : Combining Focus and Variety : The Photolithography example

We will identify knowledge creation, “idea” generation and, generally speaking, follow the cognitive process of innovation and knowledge production, using a representation of the reasoning activities proposed in one of the most recent theories of design reasoning, the C-K theory (Hatchuel and Weil, 2003)¹⁸.

The C-K theory describes a design reasoning as the interaction between two spaces, the concept space C and the knowledge space K. Design begins with an initial concept, a proposition that is neither true nor false ie is undecidable in the K space. Such a design brief cannot be said feasible or unfeasible, marketable or not,... “Reducing the physical gate length”, without specifying how to do it, is such a concept. The design process consists in refining and expanding the concept by adding attributes coming from the knowledge space (the gate can be printed using photon imprint, or e-beam, or...). The process can also lead to the production of new knowledge (eg: how to control over-etching, reticle enhancement techniques ...) to be used in the design process. The initial concept set is actually step by step partitioned in several, more refined, subsets. The process unfolds until one refined concept is enough specified to be considered as true by the designer: the concept becomes a piece of knowledge. The generic structure of a design reasoning is presented in the figure below (source: (Hatchuel 2009)¹⁹)

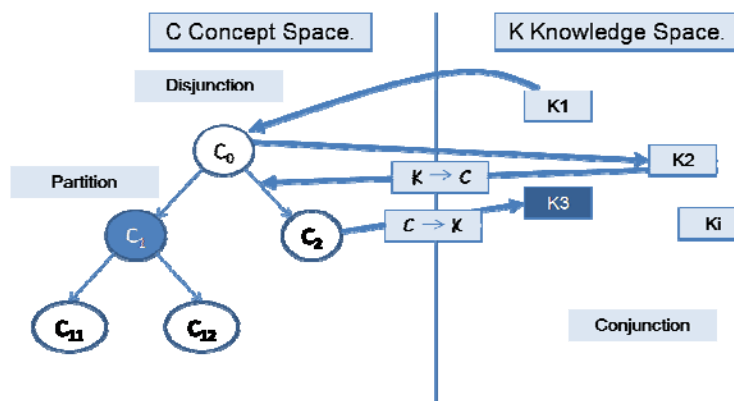

Fig. 12. The generic pattern of a design reasoning in the C-K design theory

The C-K framework helps to follow cognitive processes (expansion of knowledge space, expansion of the conceptual brief into several, varied alternatives,...). In particular, it allows to assess the intensity of knowledge acquisition (apparent when the “K” space is populated with knowledge not known at the beginning of the design process), and the

¹⁸ Hatchuel, A. and B. Weil. 2003. A new approach of innovative design: an introduction to C-K theory. Paper read at ICED'03, august 2003, at Stockholm, Sweden.

¹⁹ Hatchuel, A. 2009. C-K design theory: an advanced formulation. *Research in Engineering Design* 19:181-192

variety of the concept produced (apparent when the concept “tree” has many branches). Applying this representation to the photolithography recent past developments, and future solutions, one gets the following “high level” picture :

From mainstream technology to wildest concepts

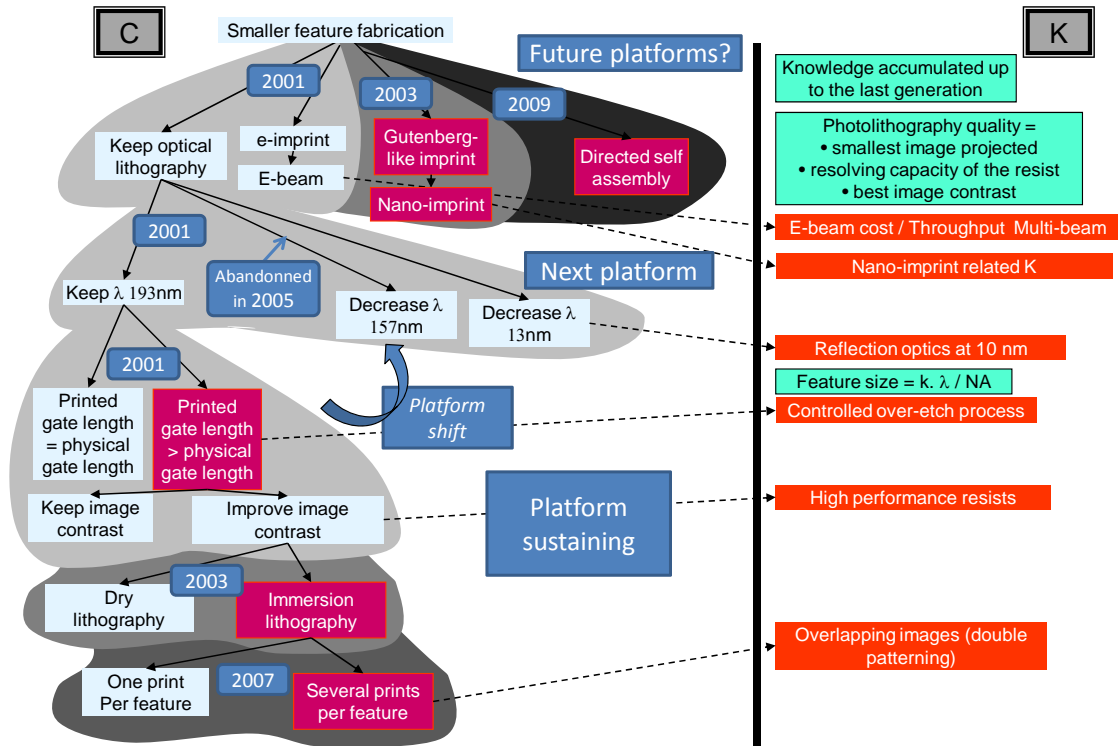

Fig. 13. Example: C-K framework for lithography

Clearly the lithography innovation process displays both knowledge intensity and variety. One would probably find similar representation in many other domains of the roadmap (see, for example, device architectures). In fact the ITRS process allows for the exploration of a variety of technical solutions to achieve a constant high rate of technological progress in the long term, while focusing on the most realistic ones for the shorter term. This, coupled with a continuous updating process, allows the incorporation of unforeseen technological breakthroughs.