

CIS 501: Computer Architecture

Unit 12: Putting it All Together: Anatomy of the Xbox 360 Game Console

Slides originally developed by Milo Martin &
Amir Roth at University of Pennsylvania

Sources

- **Application-customized CPU design: The Microsoft Xbox 360 CPU story**, Brown, IBM, Dec 2005
 - <http://www-128.ibm.com/developerworks/power/library/pa-fpfxbox/>
- **XBox 360 System Architecture**, Andrews & Baker, IEEE Micro, March/April 2006
- Microprocessor Report
 - **IBM Speeds Xbox 360 to Market**, Krewell, Oct 31, 2005
 - **Powering Next-Gen Game Consoles**, Krewell, July 18, 2005

This Unit: Putting It All Together

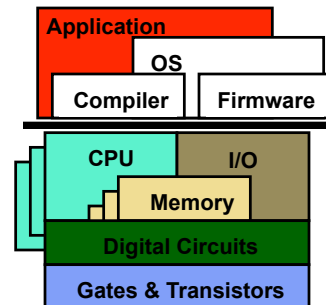

- Anatomy of a game console
 - Microsoft Xbox 360
- Focus mostly on CPU chip
- Briefly talk about system
 - Graphics processing unit (GPU)
 - I/O and other devices

What is Computer Architecture?

The role of a *computer* architect:

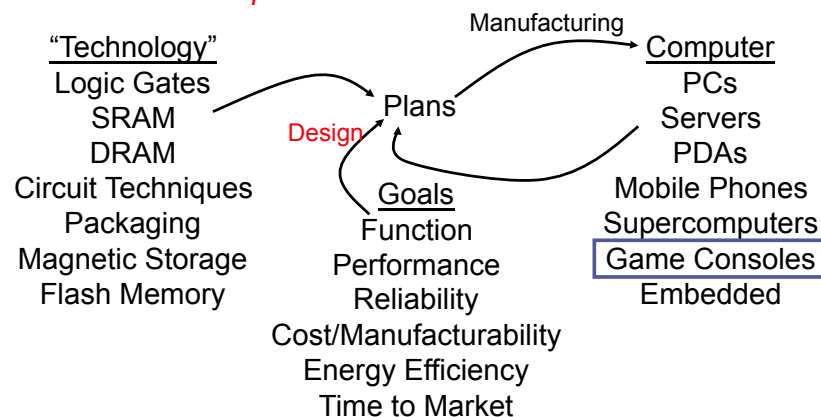

Microsoft Xbox Game Console History

- Xbox
 - First game console by Microsoft, released in 2001, \$299
 - Glorified PC
 - 733 Mhz x86 Intel CPU, 64MB DRAM, NVIDIA GPU (graphics)
 - Ran modified version of Windows OS
 - ~25 million sold
- Xbox 360
 - Second generation, released in 2005, \$299-\$399
 - All-new custom hardware
 - 3.2 Ghz PowerPC IBM processor (custom design for Xbox 360)
 - ATI graphics chip (custom design for Xbox 360)
 - 45 million sold as of Sept 2010 [Source: Wikipedia]
 - 70 million sold as of Sept 2012 [Source: Wikipedia]

Microsoft Turns to IBM for Xbox 360

- Microsoft is mostly a software company
 - Turned to IBM & ATI for Xbox 360 design
 - Sony & Nintendo also turned to IBM (for PS3 & Wii, respectively)
- Design principles of Xbox 360 [Andrews & Baker, 2006]
 - Value for 5-7 years
 - → big performance increase over last generation
 - Support anti-aliased high-definition video (720*1280*4 @ 30+ fps)
 - → extremely high pixel fill rate (goal: 100+ million pixels/s)
 - Flexible to suit dynamic range of games
 - → balance hardware, homogenous resources
 - Programmability (easy to program)
 - → listened to software developers

More on Games Workload

- Graphics, graphics, graphics
 - Special highly-parallel graphics processing unit (GPU)
 - Much like on PCs today
- But general-purpose, too
 - "The high-level game code is generally a database management problem, with plenty of object-oriented code and pointer manipulation. Such a workload needs a large L2 and high integer performance." [Andrews & Baker, 2006]
- Wanted only a modest number of modest, fast cores
 - Not one big core
 - Not dozens of small cores (leave that to the GPU)
 - Quote from Seymour Cray

Xbox 360 System from 30,000 Feet

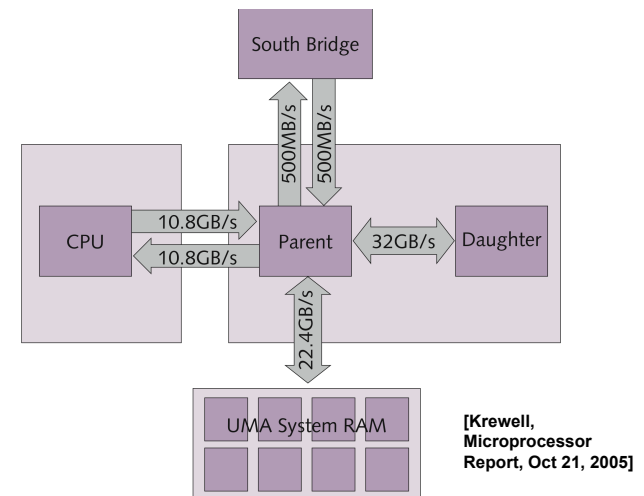

XBox 360 System

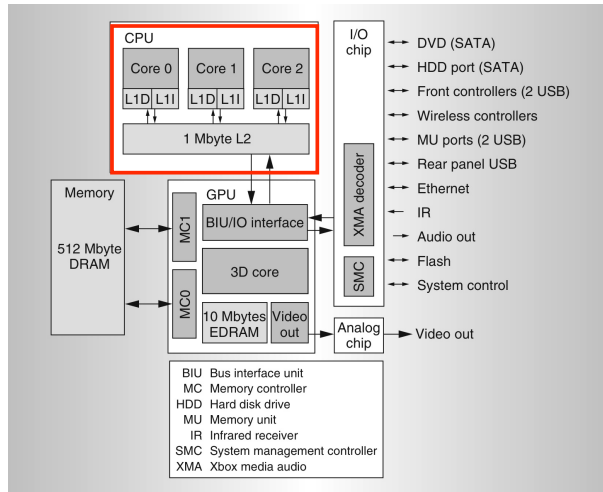

[Andrews & Baker, IEEE Micro, Mar/Apr 2006]

XBox 360 "Xenon" Processor

- ISA: 64-bit PowerPC chip
 - RISC ISA
 - Like MIPS, but with condition codes
 - Fixed-length 32-bit instructions
 - 32 64-bit general purpose registers (GPRs)
- ISA Extended with VMX-128 operations
 - **128 registers, 128-bits each**
 - Packed "vector" operations
 - Example: four 32-bit floating point numbers
 - One instruction: $VR1 * VR2 \rightarrow VR3$
 - Four single-precision operations
 - Also supports conversion to Microsoft DirectX data formats
 - Similar to AltiVec (and Intel's MMX, SSE, SSE2, etc.)
 - Works great for 3D graphics kernels and compression

XBox 360 "Xenon" Processor

- Peak performance: ~ 75 gigaflops
 - Gigaflop = 1 billion floating points operations per second
- Pipelined superscalar processor
 - 3.2 Ghz operation
 - Superscalar: two-way issue
 - VMX-128 instructions (four single-precision operations at a time)
 - Hardware multithreading: two threads per processor
 - Three processor cores per chip
- Result:
 - $3.2 * 2 * 4 * 3 = \sim 77$ gigaflops

XBox 360 "Xenon" Chip (IBM)

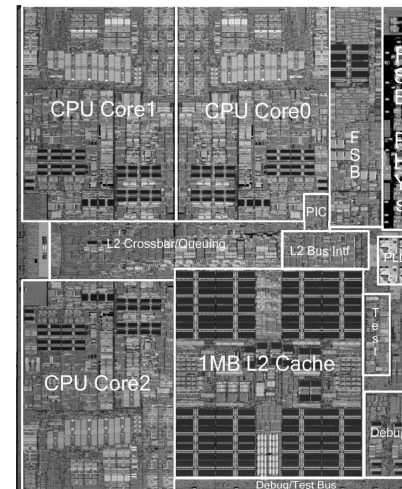

[Andrews & Baker, IEEE Micro, Mar/Apr 2006]

- 165 million transistors
 - IBM's 90nm process
- Three cores
 - 3.2 Ghz
 - Two-way superscalar
 - Two-way multithreaded
- Shared 1MB cache

"Xenon" Processor Pipeline

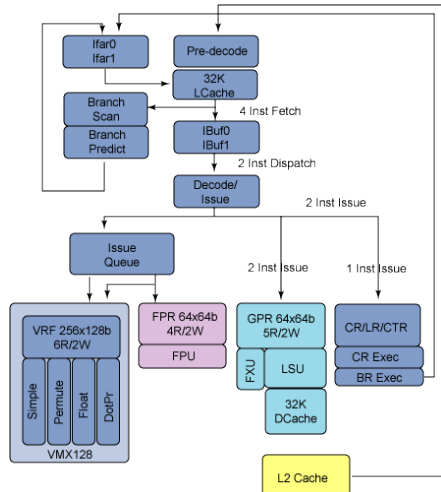

- Four-instruction fetch
- Two-instruction "dispatch"
- Five functional units
- "VMX128" execution "decoupled" from other units
 - 14-cycle VMX dot-product
- Branch predictor:
 - "4K" G-share predictor
 - Unclear if 4KB or 4K 2-bit counters
 - Per thread

[Brown, IBM, Dec 2005]

XBox 360 Memory Hierarchy

- 128B cache blocks throughout
- 32KB 2-way set-associative instruction cache (per core)
- 32KB 4-way set-associative data cache (per core)
 - Write-through, lots of store buffering
 - Parity
- 1MB 8-way set-associative second-level cache (per chip)
 - Special "skip L2" prefetch instruction
 - MESI cache coherence
 - Error Correcting Codes (ECC)
- 512MB GDDR3 DRAM, dual memory controllers
 - Total of 22.4 GB/s of memory bandwidth
- Direct path to GPU

Xenon Multicore Interconnect

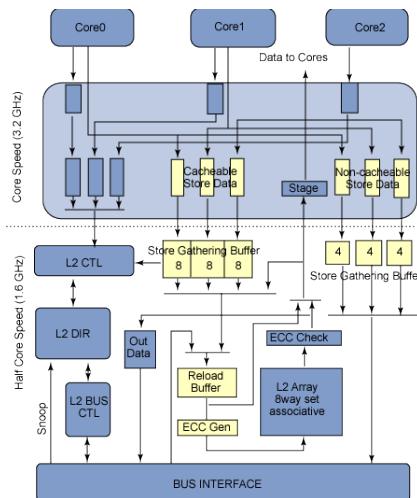

[Brown, IBM, Dec 2005]

XBox 360 System

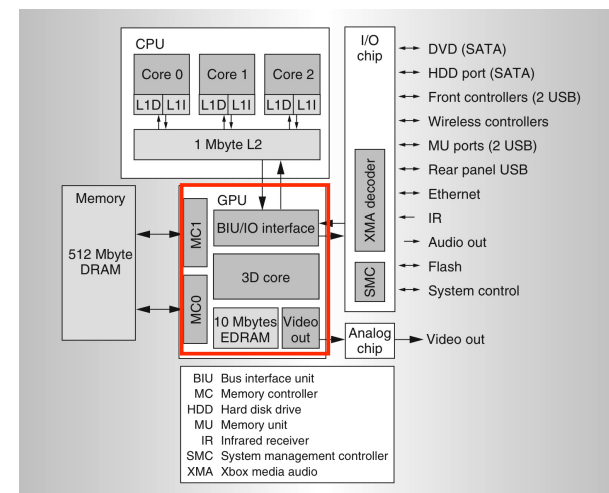

[Andrews & Baker, IEEE Micro, Mar/Apr 2006]

XBox Graphics Subsystem

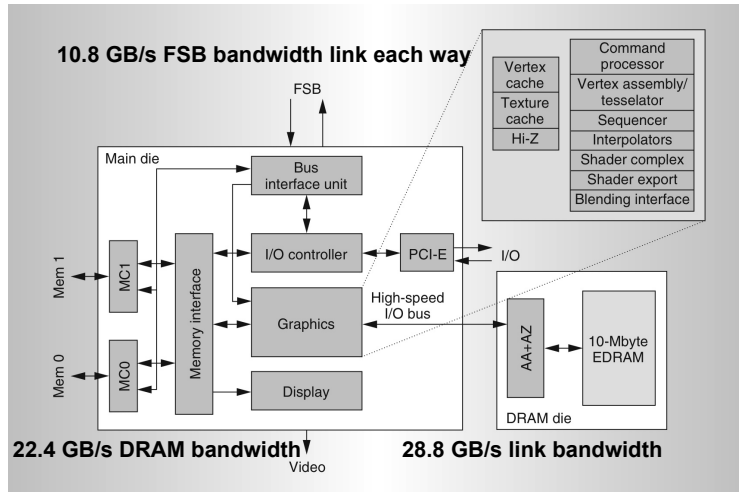

[Andrews & Baker, IEEE Micro, Mar/Apr 2006]

Graphics "Parent" Die (ATI)

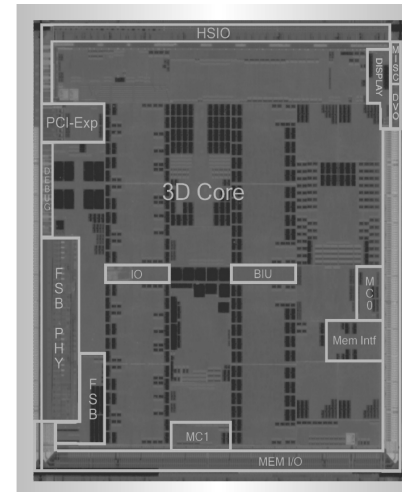

- 232 million transistors
- 500 Mhz
- 48 unified shader ALUs
 - Mini-cores for graphics

[Andrews & Baker, IEEE Micro, Mar/Apr 2006]

GPU "daughter" die (NEC)

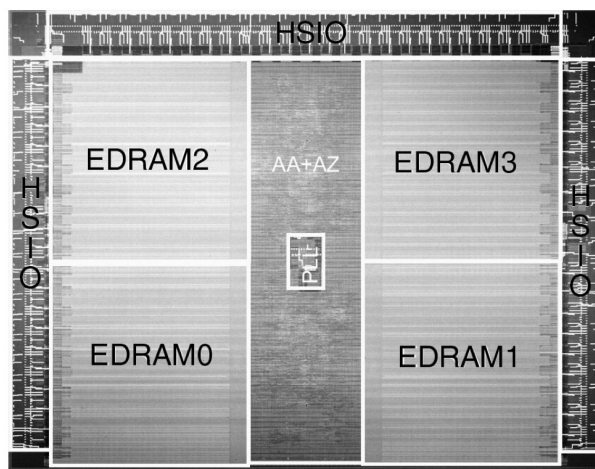

- 100 million transistors
- 10MB eDRAM
 - "Embedded"
- NEC Electronics
- Anti-aliasing
 - Render at 4x resolution, then sample
- Z-buffering
 - Track the "depth" of pixels
- 256GB/s internal bandwidth

[Andrews & Baker, IEEE Micro, Mar/Apr 2006]

Putting It All Together

- Unit 1: Introduction
- Unit 2: ISAs
- Unit 3: Technology
- Unit 4: Performance
- Unit 5: Pipelining & Branch Prediction
- Unit 6: Caches
- Unit 7: Virtual Memory
- Unit 8: Superscalar
- Unit 9: Scheduling
- Unit 10: Multicore
- Unit 11: Vectors